

ARMY TM 9-6115-644-24
AIR FORCE TO 35C2-3-446-12
MARINE CORPS TM 09249A/09246A-24/2

TECHNICAL MANUAL
UNIT, DIRECT SUPPORT AND
GENERAL SUPPORT MAINTENANCE MANUAL

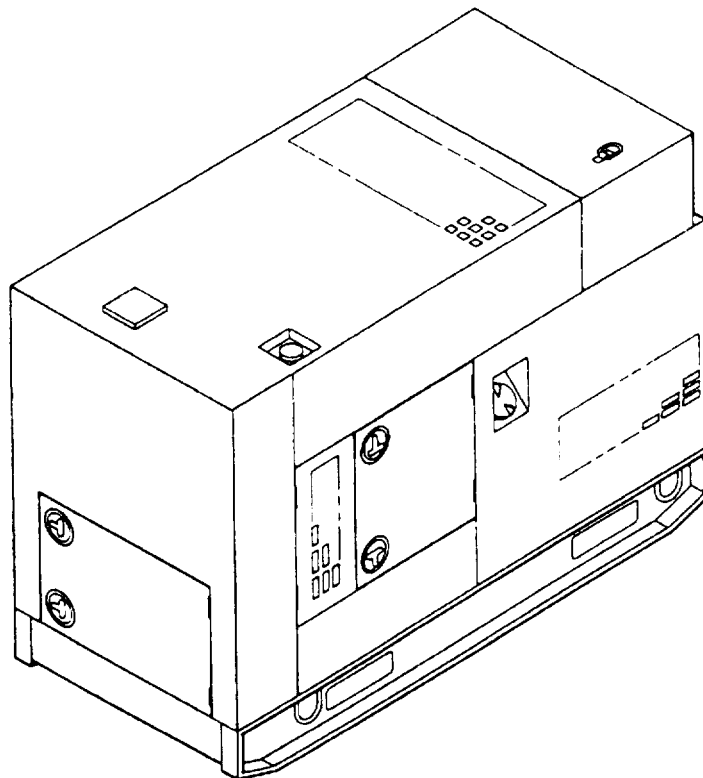

GENERATOR SET,
SKID MOUNTED, TACTICAL QUIET

30 KW, 50/60 AND 400 Hz

MEP-805A (50/60 Hz) 6115-01-274-7389

MEP-815A (400 Hz) 6115-01-274-7394

DISTRIBUTION STATEMENT A: Approved for public release; distribution is unlimited

This manual supersedes TM9-6115-644-24, dated 15 September 1993, including Change 1

HEADQUARTERS, DEPARTMENT OF THE ARMY
AIR FORCE AND HEADQUARTERS MARINE CORPS
30 APRIL 1995

CHANGE

HEADQUARTERS
DEPARTMENTS OF THE ARMY, AIR FORCE
AND HEADQUARTERS U. S. MARINE CORPS
WASHINGTON, D.C., 30 October 1996

NO. 1

UNIT, DIRECT SUPPORT AND GENERAL SUPPORT MAINTENANCE MANUAL

**GENERATOR SET, SKID MOUNTED, TACTICAL QUIET
30 kW, 50/60 AND 400 Hz
MEP-805A (50/60 Hz) 6115-01-274-7389
MEP-815A (400 Hz) 6115-01-274-7394**

DISTRIBUTION STATEMENT A: Approved for public release; distribution is unlimited

TM 9-6115-644-24/TO 35C2-3-446-12/TM 09249A/09246A-24/2, 30 April 1995, is changed as follows:

1. Remove and insert pages as indicated below. New or changed text material is indicated by a vertical bar in the margin. An illustration change is indicated by a miniature pointing hand.

Remove pages	Insert pages
i through iv	i through iv
1-21 and 1-22	1-21 and 1-22
2-11 and 2-12	2-11 and 2-12
2-19 and 2-20	2-19 and 2-20
2-25 and 2-26	2-25 and 2-26
- - - -	2-26.1/(2-26.2 blank)
2-29 through 2-32	2-29 through 2-32
2-37 and 2-38	2-37 and 2-38
2-53 through 2-66	2-53 through 2-66
- - - -	2-82.1/(2-82.2 blank)
2-83 and 2-84	2-83 and 2-84
2-109 through 2-112	2-109 through 2-112
2-117 and 2-118	2-117 and 2-118
2-121 and 2-122	2-121 and 2-122
2-129 and 2-130	2-129 and 2-130
2-153 and 2-154	2-153 and 2-154
2-157 and 2-158	2-157 and 2-158
3-11 through 3-14	3-11 through 3-14
3-21 through 3-24	3-21 through 3-24
3-27 and 3-28	3-27 and 3-28
4-15 and 4-16	4-15 and 4-16
4-27 through 4-34	4-27 through 4-34
FP-5/(FP-6 blank)	FP-5/(FP-6 blank)

2. Retain this sheet in front of manual for reference purposes.

ARMY TM 9-6115-644-24
AIR FORCE TO 35C2-3-446-12
MARINE CORPS TM 09249A/09246A-24/2
C 1

By Order of the Secretaries of the Army, Air Force, and Navy (Including the Marine Corps):

Official:

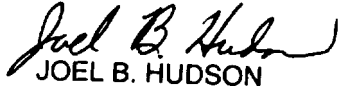

JOEL B. HUDSON
Administrative Assistant to the
Secretary of the Army
02958

DENNIS J. REIMER
General, United States Army
Chief of Staff

RONALD R. FOGELMAN
General, USAF
Chief of Staff

Official:

HENRY VICCELLIO, JR.
General, USAF
Commander, Air Force Materiel Command

J. E. BUFFINGTON
Rear Admiral, CEC, US Navy
Commander
Navy Facilities Engineering
Command

D. R. BLOOMER
Colonel, USMC
Director, Program Support
Marine Corps Systems Command

DISTRIBUTION:

To be distributed in accordance with DA Form 12-25-E, block no. 5268, requirements for
TM 9-6115-644-24.

WARNING

High voltage is produced when this generator set is in operation. Improper operation could result in personal injury or death.

WARNING

Battery acid can cause burns to unprotected skin. Wear protective clothing including rubber gloves and eye protection when servicing the batteries. Failure to observe this warning could result in severe injury or death.

WARNING

Batteries give off a flammable gas. Do not smoke or use open flame when performing maintenance. Flames and explosion could result in severe personal injury or death.

WARNING

Exhaust discharge contains deadly gases. Do not operate generator sets in enclosed areas unless exhaust discharge is properly vented outside. Severe personal injury or death due to carbon monoxide poisoning could result.

WARNING

The fuels used in this generator set are highly explosive. Do not smoke or use open flames when performing maintenance. Fire or explosion could cause serious injury or death.

WARNING

When filling the fuel tank, maintain metal-to-metal contact between filler nozzle and fuel tank opening. Failure to observe this warning could result in explosion, injury and death.

WARNING

Diesel fuel is flammable and toxic to eyes, skin and respiratory tract. Skin/eye protection required. Avoid repeated/prolonged contact. Good general ventilation is normally adequate.

WARNING

Liquids under pressure are generated as a result of operation of the generator set. High pressure leaks could cause severe personal injury or death.

WARNING

The cooling system operates at high temperatures. Personal injury or death from burns or scalding could result from high pressure steam.

WARNING

With any access door open, the noise level of this generator set when operating could cause hearing damage. Hearing protection must be worn when operating or working near the generator set while running.

WARNING

Never attempt to start the generator set if it is not properly grounded. Failure to observe this warning could result in serious injury or death by electrocution.

WARNING

Hot refueling of generator set while operating, presents a safety hazard and should not be attempted. Hot engine surfaces and sparks from the engine and generator circuitry are possible sources of ignition. Severe injury or death could result.

WARNING

Prior to making any connections for parallel operation or moving a generator set which has been operating in parallel, ensure that there is no input to the load and that the generator sets are shut down. Failure to observe this warning may result in personal injury or death by electrocution.

WARNING

Dry cleaning solvent is flammable and toxic to eyes, skin and respiratory tract. Skin/eye protection required. Avoid repeated/prolonged contact. Good general ventilation is normally adequate.

WARNING

Remove metal jewelry when working on electrical system or components. Failure to observe this warning could result in severe personal injury or death by electrocution.

WARNING

Wear a protective mask and gloves when sanding CARC painted surfaces. CARC paint dust is a health hazard and could cause personal injury if warning is not followed.

WARNING

Electrolyte contains sulfuric acid which causes severe burns. Do not allow electrolyte to come in contact with skin or clothing. Never add electrolyte to water, splattering will occur. Failure to follow this warning could result in severe burns or personal injury.

FOR FIRST AID REFER TO FM 21-11

TECHNICAL MANUAL

HEADQUARTERS
DEPARTMENTS OF THE ARMY, AIR FORCE
AND HEADQUARTERS U. S. MARINE CORPS
WASHINGTON, D.C., 30 April 1995

NO. 9-6115-644-24

UNIT, DIRECT SUPPORT AND GENERAL SUPPORT MAINTENANCE MANUAL

**GENERATOR SET, SKID MOUNTED, TACTICAL QUIET
30 kW, 50/60 AND 400 Hz
MEP-805A (50/60 Hz) 6115-01-274-7389
MEP-815A (400 Hz) 6115-01-274-7394**

REPORTING ERRORS AND RECOMMENDING IMPROVEMENTS

You can help improve this manual. If you find any mistakes or if you know of a way to improve these procedures, please let us know.

(A) Mail your letter or DA Form 2028 (Recommended Changes to Publications and Blank Forms), or DA Form 2028-2 located in the back of this manual directly to: Commander, US Army Aviation and Troop Command, ATTN: AMSAT-I-MP, 4300 Goodfellow Blvd., St. Louis, MO 63120-1798. You may also submit your recommended changes by E-mail directly to <mpmt%avma28@st-louis-emh7.army.mil> Instructions for sending an electronic 2028 may be found at the back of this publication immediately preceding the hard copy 2028.

(F) Air Force AFTO Form 22 Directly to: Commander, Sacramento Air Logistics Center, ATTN: TILBA, McClellan AFB, CA 95652-5990 (AFMC).

(M) Marine Corps - NAVMC Form 10772 Directly to: Commander, Marine Corps Logistics Bases (Code 850), Albany, GA 31704-5000.

A reply will be furnished directly to you.

DISTRIBUTION STATEMENT A: Approved for public release; distribution is unlimited.

*This manual supersedes TM 9-6115-644-24, dated 15 September 1993, including Change 1.

TABLE OF CONTENTS

	Page
HOW TO USE THIS MANUAL	viii
CHAPTER 1 INTRODUCTION	1-1
Section I. General Information	1-1
Section II. Equipment Description And Data	1-4
Section III. Principles Of Operation	1-10
CHAPTER 2 UNIT MAINTENANCE INSTRUCTIONS	2-1
Section I. Service Upon Receipt Of Equipment	2-1
Section II. Repair Parts; Special Tools; Test, Measurement, And Diagnostic Equipment (TMDE); And Special Support Equipment	2-9
Section III. Special Lubrication Instructions	2-9
Section IV. Preventive Maintenance Checks And Services (PMCS)	2-10
Section V. Troubleshooting	2-13
Section VI. Radio Interference Suppression	2-26
Section VII. Special Instructions	2-26
Section VIII. Maintenance Of Dc Electrical System	2-27
Section IX. Maintenance Of Housing	2-34
Section X. Maintenance Of Control Box Assembly	2-49
Section XI. Maintenance Of Air Intake And Exhaust System	2-110
Section XII. Maintenance Of Coolant System	2-116
Section XIII. Maintenance Of Fuel System	2-131
Section XIV. Maintenance Of Output Box Assembly	2-143
Section XV. Maintenance Of Engine Accessories	2-152
Section XVI. Maintenance Of Lubrication System	2-162
Section XVII. Preparation For Shipment And Storage	2-165
CHAPTER 3 GENERAL MAINTENANCE INSTRUCTIONS	3-1
Section I. Repair Parts; Tools; Test, Measurement, And Diagnostic Equipment (TMDE); And Special Support Equipment	3-1
Section II. Troubleshooting	3-1
Section III. Removal And Installation Of Major Components.	3-10
CHAPTER 4 DIRECT SUPPORT MAINTENANCE INSTRUCTIONS	4-1
Section I. Maintenance Of Control Box Assembly.....	4-1
Section II. Maintenance Of Coolant System	4-13
Section III. Maintenance Of Fuel System	4-13
Section IV. Maintenance Of Output Box Assembly.....	4-14
Section V. Maintenance Of Engine Accessories.....	4-26
Section VI. Maintenance Of Generator Assembly	4-29

TABLE OF CONTENTS - Continued

CHAPTER 4	DIRECT SUPPORT MAINTENANCE INSTRUCTIONS - Continued	
Section VII.	Maintenance Of Skid Base	4-44
Section VIII.	Maintenance Of Lubrication System	4-45
APPENDIX A	REFERENCES..	A-1
APPENDIX B	MAINTENANCE ALLOCATION CHART	B-1
APPENDIX C	EXPENDABLE/DURABLE SUPPLIES AND MATERIALS LIST ...	C-1
APPENDIX D	FABRICATION/ASSEMBLY OF PARTS	D-1
	INDEX	I-1

LIST OF ILLUSTRATIONS

Number		Page
FIGURE 1-1.	Generator Set, 30 kW, Tactical Quiet	1-2
FIGURE 1-2.	Fault System	1-12
FIGURE 1-3.	Generator Set Fuel System	1-14
FIGURE 1-4.	Generator Set Cooling System	1-15
FIGURE 1-5.	Engine Cooling System	1-16
FIGURE 1-6.	Engine Lubrication System	1-18
FIGURE 1-7.	Engine Air Intake and Exhaust System	1-19
FIGURE 1-8.	Output Supply System	1-20
FIGURE 1-9.	Engine Starting System	1-22
FIGURE 1-10.	Governor Control System	1-24
FIGURE 1-11.	Voltage Regulation System	1-25
FIGURE 1-12.	Generator Set Components	1-27
FIGURE 2-1.	Base Mounting Measurements	2-5
FIGURE 2-2.	Minimum Enclosure Clearance Measurements	2-7
FIGURE 2-3.	Batteries and Cables	2-29
FIGURE 2-4.	NATO Slave Receptacle and Cables	2-33
FIGURE 2-5.	Generator Set Access Doors	2-36
FIGURE 2-6.	Control Box Top Panel	2-38
FIGURE 2-7.	Generator Set Top Housing Section (Sheet 1 of 2)	2-40
FIGURE 2-8.	Generator Set Front Housing Section	2-44
FIGURE 2-9.	Generator Set Rear Housing Section	2-49
FIGURE 2-10.	Control Box Assembly	2-51
FIGURE 2-11.	Control Panel Lights	2-53
FIGURE 2-12.	Control Panel Indicators	2-60
FIGURE 2-13.	Control Panel Switches	2-72
FIGURE 2-13.1	In-Line Fuse Installation	2-82.1
FIGURE 2-14.	Control Box Components	2-86
FIGURE 2-15.	Permissive Paralleling Relay Test Set-up	2-94
FIGURE 2-16.	Reverse Power Relay Test Set-up	2-96
FIGURE 2-17.	Diagnostic Connector Pin Positions	2-102
FIGURE 2-18.	Diode Identification	2-104
FIGURE 2-19.	Control Box Panels	2-109
FIGURE 2-20.	Muffler and Exhaust Pipe	2-112
FIGURE 2-21.	Air Cleaner Assembly	2-115
FIGURE 2-22.	Drilling Radiator Cap	2-119
FIGURE 2-23.	Coolant System	2-120
FIGURE 2-24.	Fan Guards and Coolant Recovery System	2-122
FIGURE 2-25.	Fan Belt	2-129
FIGURE 2-26.	Fuel Tank Filler Neck and Low Pressure Fuel System	2-132
FIGURE 2-27.	Ether Start System	2-141
FIGURE 2-28.	Output Box Assembly	2-144
FIGURE 2-29.	Load Terminal Board Assembly	2-151
FIGURE 2-30.	Engine Switches and Senders	2-154
FIGURE 2-31.	Oil Drain Valve	2-161
FIGURE 3-1.	Engine and Generator Assembly	3-12
FIGURE 3-2.	Top Housing Panel	3-14
FIGURE 3-3.	Filler Hose and Panel Assembly	3-15
FIGURE 3-4.	Overflow Bottle Assembly	3-15
FIGURE 3-5.	Top Housing Section Assembly	3-16
FIGURE 3-6.	Radiator Assembly	3-17
FIGURE 3-7.	Rear Housing Panel	3-18

LIST OF ILLUSTRATIONS - Continued

Number	Title	Page
FIGURE 3-8.	Fuel Filler Hoses and Panel Assembly	3-18
FIGURE 3-9.	Left Side Housing Panels	3-19
FIGURE 3-10.	Air Cleaner Hose and Tube Assembly	3-19
FIGURE 3-11.	Oil Drain Hose	3-20
FIGURE 3-12.	Left Side Engine	3-20
FIGURE 3-13.	Right Side Engine	3-21
FIGURE 3-14.	Load Output Terminal Board	3-22
FIGURE 3-15.	Radiator Mounting Bracket	3-23
FIGURE 3-16.	Engine Components (Left Side)	3-27
FIGURE 3-17.	Engine Components (Right Side)	3-28
FIGURE 4-1.	Fuel Injection Pump High idle Speed Adjustment	4-7
FIGURE 4-2.	Control Box Components	4-12
FIGURE 4-3.	Fuel Tank	4-15
FIGURE 4-4.	Output Box Assembly	4-17
FIGURE 4-5.	Testing Current Transformer	4-21
FIGURE 4-6.	Testing Droop Current Transformer.	4-22
FIGURE 4-7.	Governor Actuator Assembly	4-27
FIGURE 4-8.	Governor Actuator Adjustment.	4-29
FIGURE 4-9.	Brushless Generator Schematic	4-30
FIGURE 4-10.	Generator Assembly Removal	4-31
FIGURE 4-11.	Rectifier Assembly	4-34
FIGURE 4-12.	End Bell Removal	4-36
FIGURE 4-13.	Generator Assembly	4-37
FIGURE 4-14.	Rotor Assembly Lifting Device (Typical)	4-42
FIGURE 4-15.	Skid Base	4-45
FIGURE D-1.	Cable Assembly, AC Power (P/Ns: 88-22126-1 through 88-22126-7)	D-1
FIGURE D-2.	Cable Assembly, Battery (P/N: 88-22178)	D-2
FIGURE D-3.	Cable Assembly, Battery (P/N: 88-22127)	D-3
FIGURE D-4.	Cable Assembly, Battery (P/N: 88-22181)	D-4
FIGURE D-5.	Cable Assembly, Battery (P/N: 88-22179)	D-5
FIGURE D-6.	Cable Assembly, Battery (P/N: 88-22207)	D-6
FIGURE D-7.	Holder, Control Panel (P/N: 88-22120)	D-7
FIGURE D-8.	Hose Assembly (P/N: 88-20191 -6)	D-8
FIGURE D-9.	Insulation, Panel, Top(P/N: 88-22582)	D-9
FIGURE D-10.	Insulation, Baffle (P/N: 88-22592)	D-10
FIGURE D-11.	Insulation, Baffle (P/N: 88-22593)	D-11
FIGURE D-12.	Insulation, Top, Center (P/N: 88-22584)	D-12
FIGURE D-13.	Insulation, Top, Rear (P/N: 88-22585)	D-13
FIGURE D-14.	Insulation, Front Housing (P/N: 88-22591)	D-14
FIGURE D-15.	Insulation, Top, Front (P/N: 88-22586)	D-15
FIGURE D-16.	Insulation, Top, Center (P/N: 88-22587)	D-16
FIGURE D-17.	Insulation, Top, Center (P/N: 88-22588)	D-17
FIGURE D-18.	Insulation, Top, Front (P/N: 88-22583)	D-18
FIGURE D-19.	Pump Assembly, Fuel (P/N: 88-22546)	D-19
FIGURE D-20.	Resistor Assembly (P/Ns: 122-3066-1 and 29879)	D-20
FIGURE D-21.	Resistor Assembly, Volt (P/N: 88-22631)	D-21
FIGURE D-22.	Resistor-Diode Assembly (P/N: 88-22632)	D-22
FIGURE D-23.	Resistor-Diode Assembly (P/N: 88-22106)	D-23
FIGURE D-24.	Solenoid Assembly (P/N: 88-22553)	D-24
FIGURE D-25.	Switch Assembly, Fuel Level (P/N: 88-22548)	D-25

LIST OF ILLUSTRATIONS - Continued

Number	Title	Page
FIGURE D-26.	Wire, Varistor (P/Ns: 66-20305-1 through 66-20305-3, and 66-20305-5) . .	D-26
FO-1	Electrical Schematic	FP-1 (FP-2 Blank)
FO-2	Wiring Diagram	FP-3 (FP-4 Blank)

LIST OF TABLES

Number	Title	Page
TABLE 1-1.	Tabulated Data	1-4
TABLE 1-2.	Performance Characteristics	1-9
TABLE 2-1.	Coolant	2-3
TABLE 2-2.	Fuel	2-4
TABLE 2-3.	Lubricating Oil	2-4
TABLE 2-4.	Fabricated/Assembled Parts	2-8
TABLE 2-5.	Unit Preventive Maintenance Checks and Services	2-11
TABLE 2-6.	Unit Troubleshooting	2-15
TABLE 2-7.	State of Charge with Specific Gravity Corrected to 80°F (27°C)	2-30
TABLE 2-8.	Specific Gravity Temperature Corrections	2-31
TABLE 2-9.	Diagnostic Connector Connection Points	2-100
TABLE 3-1.	Direct Support Troubleshooting	3-3
TABLE D-1.	INCHES TO METRIC CONVERSION	D-27

HOW TO USE THIS MANUAL

In this manual (TM 9-6115-644-24), paragraphs are underlined and the sections and chapters appear in capital letters. The location of additional material that must be referenced is clearly marked. Illustrations in this text are located as close as possible to their references.

Chapter 1 - INTRODUCTION. Contains general information, equipment description and data, and principles of operation for the generator set.

Chapter 2 - UNIT MAINTENANCE INSTRUCTIONS. Contains information on servicing the generator set and components upon receipt, Unit level Preventive Maintenance Checks and Services (PMCS), troubleshooting procedures used to recognize and correct generator set malfunctions, and all maintenance procedures authorized at Unit level.

Chapter 3 - GENERAL MAINTENANCE INSTRUCTIONS. Contains Direct Support level troubleshooting procedures used to recognize and correct generator set malfunctions, and procedures for the removal and installation of major components.

Chapter 4 - DIRECT SUPPORT MAINTENANCE INSTRUCTIONS. Contains all maintenance procedures authorized to be performed on the generator set at the Direct Support level.

APPENDICES.

Appendix A is a list of publications referenced in this manual and should be used in conjunction with this manual.

Appendix B is the Maintenance Allocation Chart (MAC) which designates all maintenance and repair functions authorized to be performed at the different maintenance levels.

Appendix C is the Expendable/Durable Supplies and Materials List (EDSML) which lists all expendable/durable supplies and materials required in performing the maintenance procedures presented in this manual.

Appendix D lists all parts that require fabrication or assembly for the maintenance of the generator set. Materials and procedures required are included.

Index. The index contains key technical manual subjects arranged in alphabetical order. If you require information on a spade subject (i.e., Time Meter), but you are not sure whereto look, use the index to locate specific paragraph.

CHAPTER 1 INTRODUCTION

Section I GENERAL INFORMATION

1-1 SCOPE.

This manual contains Unit, Direct Support and General Support maintenance instructions for the Tactical Quiet (TQ), 30 kW 50/60 and 400 Hz Generator Sets (FIGURE 1-1), herein referred to as generator sets. Included are descriptions of major components and their functions in relation to other components.

<u>Model Number</u>	<u>Equipment Name</u>
MEP-805A	Generator Set, Skid Mounted, Tactical Quiet 30 kW 50/60 Hz
MEP-815A	Generator Set, Skid Mounted, Tactical Quiet 30 kW 400 Hz

The generator set provides tactical quiet AC power. The generator set is easily transported, operated, and maintained.

1-2 LIMITED APPLICABILITY.

Some portions of this publication are not applicable to all services. These portions are prefixed to indicate the service(s) to which they pertain: (A) for Army, (F) for Air Force, (N) for Navy, and (MC) for Marine Corps.

1-3. MAINTENANCE FORMS AND RECORDS.

1-3-1 (A) Department of the Army forms and procedures used for equipment maintenance will be those prescribed by DA PAM 738-750, The Army Maintenance Management System (TAMMS).

1-3-2 (F) Maintenance Forms and Records maintained by the Air Force are prescribed in AFR 66-1 and the applicable TO 00-20 Series Technical Orders.

1-3-3 (N) Navy users should refer to their service Peculiar directives to determine the applicable maintenance forms and records to be used.

1-3-4 (MC) Maintenance Forms and Records used by the Marine Corps personnel are prescribed by current edition of TM 4700-15/1.

1-4 REPORTING OF ERRORS.

Reporting of errors, omissions, and recommendations for improvement of this publication by the individual user is encouraged. Reports should be submitted as follows:

1-4-1 (A) Mail your letter, DA Form 2028 (Recommended Changes to Publications and Blank Forms), or DA Form 2028-2 located in back of this manual direct to:

Commander
U.S. Army Aviation and Troop Command
Attn: AMSAT-I-MP
4300 Goodfellow Blvd.
St. Louis, MO 63120-1798

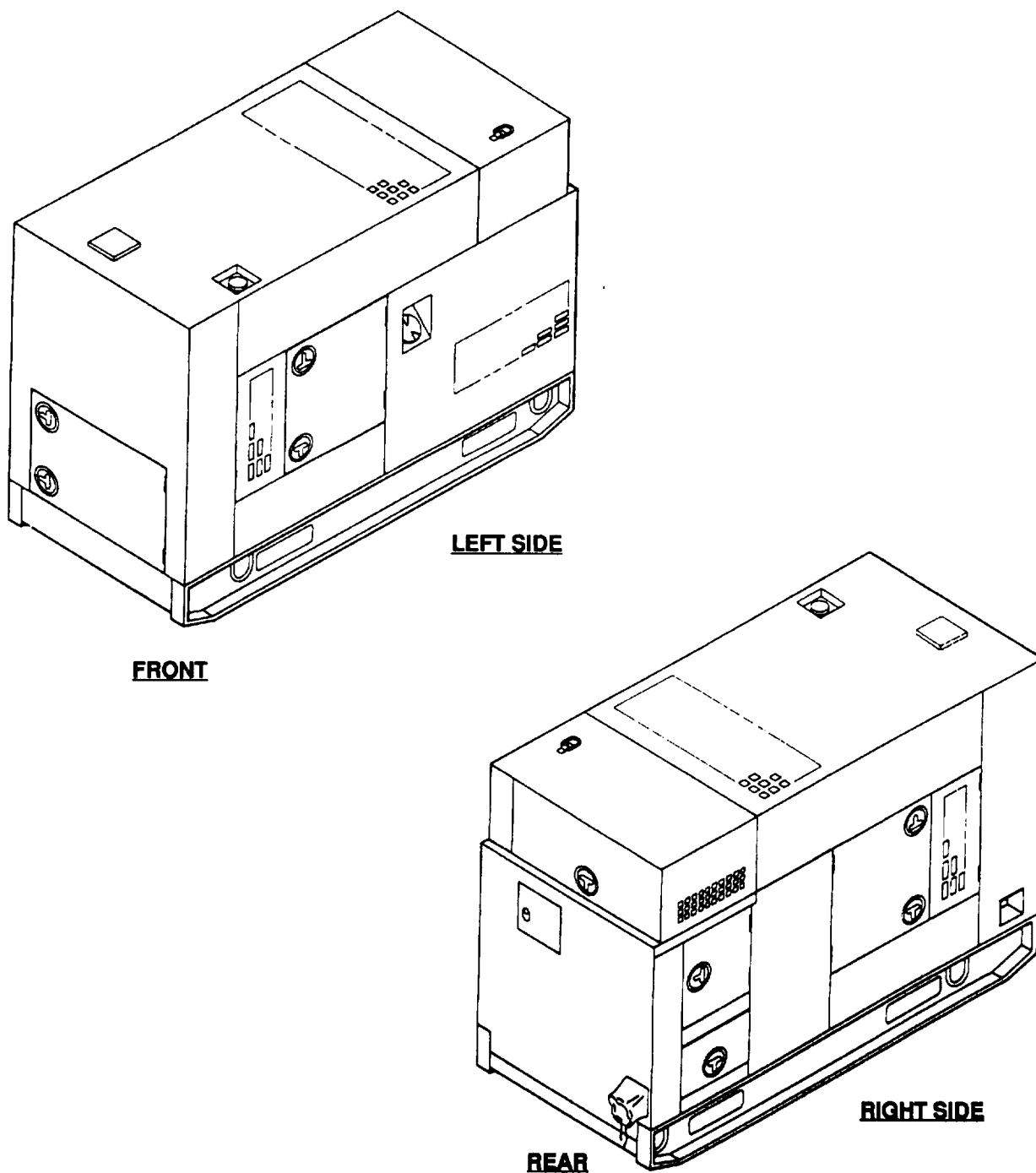

FIGURE 1-1. Generator Set, 30 kW, Tactical Quiet

1-4-2 (F) Air Force - AFTO Form 22 directly to:

Commander
Sacramento Air Logistics Center
(AFMC)
Attn: TILBA
McClellan AFB, CA 95652-5990

1-4-3 (N) Navy - by letter directly to:

Commander
U.S. Navy Ships Parts Control Center
Attn: Code 783
Mechanicsburg, PA 17055

1-4-4 (MC) Marine Corps - NAVMC Form 10772 directly to:

Commander
Marine Corps Logistics Bases
(Code 850)
Albany, GA 31704-5000

1-5 EQUIPMENT IMPROVEMENT RECOMMENDATIONS (EIRS).

1-5-1 If your generator set needs improvement, let us know. Send us an EIR. You, the user, are the only one who can tell us what you don't like about your equipment. Let us know why you don't like the design or performance. We will send you a reply.

1-5-2 (A) Put it on an SF 368 (Product Quality Deficiency Report). EIRs should be mailed directly to:

Commander
U.S. Army Aviation and Troop Command
Attn: AMSAT-I-MDC
4300 Goodfellow Blvd.
St. Louis, MO 63120-1798

1-5-3 (N) Put it on applicable Navy form and mail it directly to:

Naval Construction Battalion Center
Attn: Code 157 Civil Engineer
Support Office (CESO)
Port Hueneme, CA 93043-5000

1-5-4 (F) Send QDR/MDR by electric message to:

SMALC
McClellan AFB CA//TILE//
For technical assistance notify:

SM-ALC/LIEAE
Attn: Equipment Specialist, TQG
McClellan AFB, CA 95652-5990

1-5-5 (MC) Quality Deficiency Reports (QDR) shall be submitted on SF 368 in accordance with MCO 4855.10. Submit to:

Commander
Marine Corps Logistics Bases
(Code 856)
Albany, GA 31704-5000

1-6 LEVELS OF MAINTENANCE.

1-6-1 (A) Army users shall refer to the Maintenance Allocation Chart (MAC) for tasks and levels of maintenance to be performed.

1-6-2 (F) (MC) Refer to the Source Maintenance Recoverability (SMR) Codes for maintenance to be performed.

1-6-3 (N) Navy users shall determine their maintenance levels in accordance with their service directives.

1-7 DESTRUCTION OF MATERIEL TO PREVENT ENEMY USE.

1-7-1 (A) (MC) Destruction of the generator set to prevent enemy use shall be in accordance with TM 750-244-3.

1-7-2 (F) (N) Air Force and Navy users shall refer to their service directives to obtain procedures for destruction of materiel to prevent enemy use.

Section II. EQUIPMENT DESCRIPTION AND DATA

1-8 GENERAL.

The generator sets, models MEP-805A and MEP-815A, (FIGURE 1-1) are fully enclosed, self-contained, skid-mounted, portable units. They are equipped with controls, instruments, and accessories necessary for operation as single units or in parallel with another unit of the same class and mode. The generator sets consist of a diesel engine, brushless generator, excitation system, speed governing system, fuel system, 24 VDC starting system, control system, and fault system.

1-9 TABULATED/ILLUSTRATED DATA.

For a list of Tabulated Data refer to TABLE 1-1.

TABLE 1-1. Tabulated Data

	MEP-805A	MEP-815A
1. Generator Set:		
a. National Stock Number	6115-01-274-7389	6115-01-274-7394
b. Overall Length	79.7 in. (202.5 cm)	79.7 in. (202.5 cm)
c. Overall Width	35.7 in. (90.8 cm)	35.7 in. (90.8 cm)
d. Overall Height	55 in. (139.7 cm)	55 in. (139.7 cm)
e. Dry Weight (less Basic Issue Items List)	2732 lb. (1239.2 kg)	2732 lb. (1239.2 kg)
f. Wet Weight	2931 lb. (1329.5 kg)	2931 lb. (1329.5 kg)

TABLE 1-1. Tabulated Data - Continued

	MEP-805A	MEP-815A
2. Engine:		
a. Manufacturer	John Deere	John Deere
b. Model	4039T	4039T
c. Type	Four cylinder, four cycle, turbocharged diesel	Four cylinder, four cycle, turbocharged diesel
d. Displacement	239 cu. in. (3.9 liters)	239 cu. in. (3.9 liters)
e. Altitude Degradation 4000 ft. (1220 m) to 8000 ft. (2440 m)	3.5% per 1000 ft. (305 m)	3.5% per 1000 ft. (305 m)
f. Firing Order	1,3,4,2	1,3,4,2
g. Cold Weather Starting Aid System Use	40° F (4°C) or below	40°F (4°C) or below
h. Valve Tappet Clearance Adjustment: Hot or Cold (Intake)	0.014 in. (0.35 mm)	0.014 in. (0.35 mm)
Hot or Cold (Exhaust)	0.018 in. (0.45 mm)	0.018 in. (0.45 mm)
3. Cooling System:		
a. Type	Pressurized radiator and pump	Pressurized radiator and pump
b. Capacity	15.5 qts. (14.7 liters)	15.5 qts. (14.7 liters)
c. Normal Operating Temperature	170-200°F (77-93°C)	170-200°F (77-93°C)
d. Temperature Indicating System Voltage Rating	24 VDC	24 VDC
4. Lubricating System:		
a. Type	Full flow, circulating pressure	Full flow, circulating pressure
b. Oil Pump Type	Positive displacement gear	Positive displacement gear

TABLE 1-1. Tabulated Data - Continued

	MEP-805A	MEP-815A
4. Lubricating System - Continued:		
c. Normal Operating Pressure	25-60 psi (172-414 kPa)	25-60 psi (172-414 kPa)
d. Oil Filter Type	Full flow, spin-on replaceable element	Full flow, spin-on replaceable element
e. Capacity	15 qts. (14.2 liters)	15qts. (14.2 liters)
f. Pressure Indicating System Voltage Rating	24 VDC	24 VDC
5. Fuel System:		
a. Type of Fuel	DF-1, DF-2, DF-A, JP4, JP5, JP8	DF-1 , DF-2, DF-A, JP4, JP5, JP8
b. Fuel Tank Capacity	23 gal. (87.1 liters)	23 gal. (87.1 liters)
c. Fuel Consumption Rate	2.60 gal. (9.8 liters) per hour	2.75 gal. (10.4 liters) per hour
d. Auxiliary Fuel Pump:		
(1) Voltage Rating	24 VDC	24 VDC
(2) Delivery Pressure	5-6.5 psi (34.5-65.5 kPa) (max)	5-6.5 psi (34.5-65.5 kPa) (max)
e. Fuel Level Switch:		
(1) Type	Float	Float
(2) Current	0.6 amps (rein) at 24 VDC	0.6 amps (min) at 24 VDC
6. Engine Starting System:		
a. Batteries	Two 12 volt, connected in series	Two 12 Volt, connected in series

TABLE 1-1. Tabulated Data - Continued

	MEP-805A	MEP-815A
6. Engine Starting System - Continued:		
b. Starter:		
(1) Manufacturer	Nippondenso Co. Ltd	Nippondenso Co. Ltd
(2) Model	RE39930A	RE39930A
(3) Voltage Rating	24 VDC	24 VCD
(4) Drive Type	Gear reduction	Gear reduction
c. Battery Charging Alternator:		
(1) Manufacturer	Prestolite	Prestolite
(2) Model	8EM3002GC	8EM3002GC
(3) Rating	42 amps at 24 VDC	42 amps at 24 VDC
(4) Protective Fuse	30 amps	30 amps
7. AC Generator:		
a. Manufacturer	Marathon Electric	Marathon Electric
b. Type	Rotating field, synchronous	Rotating field, synchronous
c. Load Capacity	30 KW	30 KW
d. Current Ratings:		
(1) 120/208 volt connection	60 Hz: 104 amps 50 Hz: 86 amps	104 amps
(2) 240/416 volt connection	60 Hz: 52 amps 50 Hz: 43 amps	52 amps
e. Power Factor	0.8	0.8
f. Cooling	Fan Cooled	Fan Cooled
g. Drive Type	Direct Coupling	Direct Coupling
h. Duty Classification	Continuous	Continuous
B. Governing System:		
a. Load Measuring Unit:		

TABLE 1-1. Tabulated Data - Continued

	MEP-805A	MEP-815A
8. Governing System - Continued:		
(1) Manufacturer	Technology Research	Technology Research
(2) Model	19310	19310
b. Governor Control Unit:		
(1) Manufacturer	Barber-Colman	Barber-Colman
(2) Model	DYNA 10502-002-0-2	DYNA 10502-002-0-2
9. Protective Devices:		
a. Low Oil Pressure switch:		
(1) Trip Pressure	15 ± 3 psi (103.4 ± 20.7 kPa)	15 ± 3 psi (103.4 ± 20.7 kPa)
(2) Voltage Rating	24 VDC	24 VDC
(3) Current Rating	7 amps	7 amps
b. Coolant High Temperature Switch:		
(1) Trip Temperature	225 ± 5° F (107 ± 3° C)	225 ± 5° F (107 ± 3° C)
(2) Voltage Rating	24 VDC	24 VDC
(3) Current Rating	7 amps	7 amps
c. Overspeed Switch:		
(1) Element Trip and Reset	2200 ± 40 RPM	2200 ± 40 RPM
(2) Voltage Rating	28 VDC	28 VDC
(3) Current Rating	1 amp	1 amp
d. Overvoltage Relay:		
(1) Trip Point Conditions	153 ± 3 VAC for no less than 200 milliseconds (120 VAC coil winding)	153 ± 3 VAC for no less than 200 milliseconds (120 VAC coil winding)
(2) Trip Point	No more than 1.25 seconds after trip conditions exist	No more than 1.25 seconds after trip conditions exist

1-10 DIFFERENCES BETWEEN MODELS.

1-10-1 The differences between models of the generator sets covered in this manual are as follows:

- a. Model MEP-805A is equipped with a 50/60 Hz generator, 50/60 Hz frequency meter, and 50/60HZ frequency selector switch.
- b. Model MEP-815A is equipped with a 400 Hz generator and 400 Hz frequency meter.

1-10-2 Performance characteristics for the two models are shown in TABLE 1-2.

TABLE 1-2. Performance Charateristics

	MEP-805A	MEP-815A
Voltage:		
(a). Voltage wave form deviation factor	5% (max)	5% (max)
Single voltage harmonics:	2% (max)	2% (max)
(b) Voltage unbalance	5% of rated voltage (max)	5% of rated voltage (max)
(c) Phase balance voltage	1% of rated voltage (max)	1% of rated voltage (max)
(d) Voltage modulation	1% (max)	1% (max)
(e) Voltage regulation	1% (max)	1% (max)
(f Short-term stability (30 seconds)	1% of rated voltage	1% of rated voltage
(g) Long-term stability (4 hours)	2% of rated voltage	2% of rated voltage
(h) Voltage drift (60° F (16° C) in 8-hour period)	± 1% (max)	± 1% (max)
(i) Dip and rise for rated load	15% of rated voltage (max)	12% of rated voltage (max)
Recovery time	0.5 seconds	0.5 seconds
(j) Dip for low power factor load	30% of no-load voltage (max)	25% of no-load voltage (max)
Recovery time	0.7 seconds 85% of no-load voltage	0.7 seconds 95% of no-load voltage

TABLE 1-2. Performance Characteristics - Continued

	MEP-805A	MEP-815A
1. Voltage - Continued:		
(k) Adjustment range VAC	50 Hz	400 Hz
120/208V connection	190-213V	197-229V
240/416V connection	380-426V	395-458V
120/208V connection	60 Hz	
240/416V connection	197-240V	
240/416V connection	395-480V	
2. Frequency:		
(a) Regulation	0.25% of rated frequency	0.25% of rated frequency
(b) Short-term steady-state stability (30 seconds)	0.5% of rated frequency	0.5% of rated frequency
(c) Long-term steady-state stability (4 hours)	1% of rated frequency	1% of rated frequency
(d) Frequency drift (60° F (16°C) in 8 hour period)	0.5% (max)	0.5% (max)
(e) Undershoot with application of load	4% of rated frequency (max)	1.5% of rated frequency (max)
Recovery time	2 seconds	1 second
(f) Overshoot with application of load	4% of rated frequency (max)	1.5% of rated frequency (max)
Recovery time	2 seconds	1 second
(g) Adjustment range	48-52 Hz, not below 45 Hz for 50 Hz operation	390-420 Hz, not below 370 Hz or above 430 Hz
	58-62 Hz, not above 65 Hz for 60 Hz operation	

Section III. PRINCIPLES OF OPERATION

1-11 INTRODUCTION.

This section contains functional descriptions of the generator set and explains how the controls and indicators interact with the systems, and the location and description of major components.

1-12 PRINCIPLES OF OPERATION

1-12-1 Fault System

1-12-1-1 The Fault System (FIGURE 1-2) protects the generator set and any connected load against the potential faults described below and provides an indication of any incurred fault. The following summary of the Fault System will assist in understanding the operation of the other generator set systems. Additional details relating to specific protection devices are also provided in the descriptions of the respective systems.

1-12-1-2 The Fault System consists of the malfunction indicator, low fuel level float switch, fuel float switch module, fuel level relay, low oil pressure switch, coolant high temperature switch, overvoltage relay, overload/short circuit relay, overspeed switch, overspeed relay, OVERSPEED RESET switch, undervoltage relay, reverse power relay, engine fault relay, electrical fault relay, and BATTLE SHORT switch. In addition to the fault indicator lamps, the malfunction indicator includes the PUSH TEST & RESET LAMPS switch which when depressed, illuminates all the lamps and resets any fault indication.

1-12-1-3 Activation of any one of the following protection devices will cause three events to occur. The AC circuit interrupter relay will open; the generator set engine will be shut down; and a fault indicator lamp will be illuminated to show which malfunction occurred.

1-12-1-3-1 Coolant High Temperature Switch. This device will activate when the engine coolant leaving the engine exceeds $225 \pm 5^\circ \text{ F}$ ($107 \pm 3^\circ \text{ C}$).

1-12-1-3-2 Low Oil Pressure Switch. This device activates when the engine lubrication oil pressure falls below $15 \pm 3 \text{ psi}$ ($103.4 \pm 20.7 \text{ kPa}$).

1-12-1-3-3 Low Fuel Level Float Switch. This device will activate when the fuel level falls to a point at which the operating time of the set at rated load is four minutes.

1-12-1-3-4 Overvoltage Relay. This device will activate when the 120-volt generator coil winding has risen to and remained at any value greater than $153 \pm 3 \text{ volts}$.

1-12-1-3-5 Overspeed Relay. This device will activate when the engine speed exceeds $2200 \pm 40 \text{ RPM}$.

1-12-14 Fuel Float Switch Module.

This device prevents inadvertent engine shutdown by providing a one second delay after actuation of the low fuel level float switch.

1-12-1-5 Electrical protection devices will cause two events to occur. The AC circuit interrupter relay will open, and a fault indicator lamp will illuminate to indicate which fault occurred.

1-12-1-5-1 Short Circuit Relay. This device will activate when the set output current in any phase exceeds 425 percent of the rated value.

1-12-1-5-2 Overload Relay. This device will operate when the load current in any phase exceeds 110 percent of rated value.

1-12-1-5-3 Undervoltage Relay. This device will activate instantaneously when the 120 volt generator coil winding has dropped to 48 volts and will trip after time delay when the coil voltage drops below 99 volts.

1-12-1-5-4 Reverse Power Relay. This device will operate if power flow into the generator set exceeds 20 percent of rated value.

1-12-1-6 Although it is possible for more than one fault to occur at one time during operation, only the first fault to occur will be displayed by the malfunction indicator. The activated indicator lamp circuit remains illuminated until the malfunction indicator is reset. The lamp will be off with the MASTER SWITCH in the OFF position and will be reilluminated when the MASTER SWITCH is turned to one of the RUN positions. Resetting a fault indication is done in two steps. First push the PUSH TEST & RESET LAMPS switch located on the malfunction indicator. Then move the MASTER SWITCH to the OFF position. After a shutdown due to engine overspeed, the OVERSPEED RESET switch must be actuated to reset the engine electrical control circuit before the engine can be restarted.

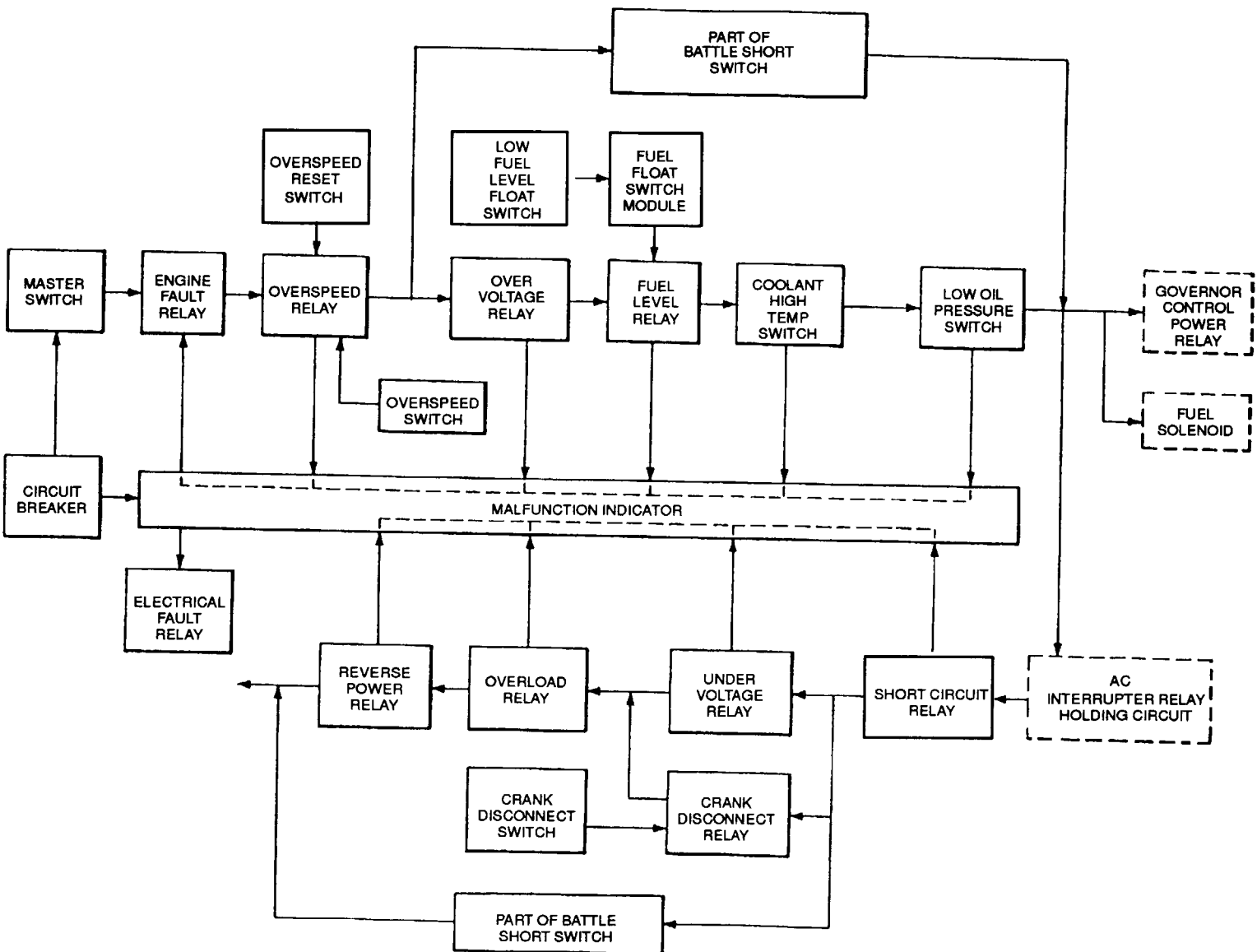

FIGURE 1-2. Fault System

1-12-1-7 After the generator set engine has been started, the BATTLE SHORT switch can be used to override all of the potential faults except engine overspeed and short circuit.

1-12-2 Fuel System.

1-12-2-1 The Fuel System (FIGURE 1-3) includes a primary subsystem and an auxiliary subsystem.

1-12-2-2 The primary subsystem consists of fuel lines, fittings, fuel tank, low fuel level float switch, fuel float switch module, fuel level sender, FUEL LEVEL indicator, transfer pump, fuel filter/water separator, injection pump and injectors. The injection pump includes a 24 VDC fuel shutoff valve.

1-12-2-3 The injection pump output is controlled by the electronic governor control and governor actuator. The electronic governor control is energized, and the fuel shutoff valve in the injection pump is energized open whenever the MASTER SWITCH is in the START position or either of the two RUN positions. With the engine cranking or running, fuel is drawn from the fuel tank by the transfer pump. After reaching the transfer pump, fuel passes through a fuel filter/water separator where water and small impurities are removed. The fuel then goes to the injection pump. With the governor system energized, the fuel is metered, pressurized and pushed through the injectors by the injection pump. Fuel is sprayed by the injectors into the diesel engine combustion chambers where it is mixed with air and ignited. The fuel that is not used by the injectors is returned to the fuel tank by an excess fuel return line. Power is removed from the electronic governor control, and the fuel is shutoff whenever the MASTER SWITCH is turned to the OFF position. The electronic governor control is also deenergized by the Fault System (refer to Paragraph 1-12-1-3). The FUEL LEVEL indicator displays the fuel level of the fuel tank from E (empty) to F (full) in quarter tank increments.

1-12-2-4 The auxiliary subsystem consists of an auxiliary fuel supply, fuel lines, fittings, auxiliary fuel filter, auxiliary fuel pump, an auxiliary fuel pump float switch located in the fuel tank, and a fuel float switch module.

1-12-2-5 When the MASTER SWITCH is set on PRIME & RUN AUX FUEL, it actuates the auxiliary fuel pump and transfers fuel from the auxiliary fuel supply to the fuel tank. The auxiliary fuel pump float switch shuts off the auxiliary fuel pump when the fuel tank is full and reactivates the pump as the level drops. The fuel float switch module allows the current used by the auxiliary fuel pump to bypass the float switch.

1-12-2-6 The 24VDC control circuits provide control and power for indicators, float switches, fault system, governor control system, and auxiliary fuel pump.

1-12-3 Generator Set Cooling System.

1-12-3-1 The Generator Set Cooling System (FIGURE 1-4) includes air intake and exhaust grilles, baffles and ducting within the generator set housing and the engine driven radiator cooling fan. The air intake grilles are located in panels on both sides of the generator set housing. The air exhaust grille is located in the housing top panel.

1-12-3-2 Air is drawn in through the air intake grilles and forced through the engine coolant radiator and out of the generator set through the exhaust grille by the radiator cooling fan. Most of the cooling air flows externally past the generator assembly and engine. Some cooling air is circulated internally through the generator assembly. Baffles, ducting, and sound absorbing material are used to control the air flow through the generator set and to reduce sound transmission through the grilles.

1-12-4 Engine Cooling System.

1-12-4-1 The Engine Cooling System (FIGURE 1-5) consists of a radiator, hoses, thermostat, temperature sender, coolant high temperature switch, COOLANT TEMP indicator, water pump, oil cooler, cooling fan, and cooling jackets (part of engine).

1-12-4-2 The water pump forces coolant through passages (cooling jackets) in the engine block and cylinder head where the coolant absorbs heat from the engine. When the engine reaches normal operating temperature, the thermostat opens and the heated coolant flows through the upper radiator hose assembly into the radiator. The cooling fan circulates air through the radiator where the coolant temperature is reduced.

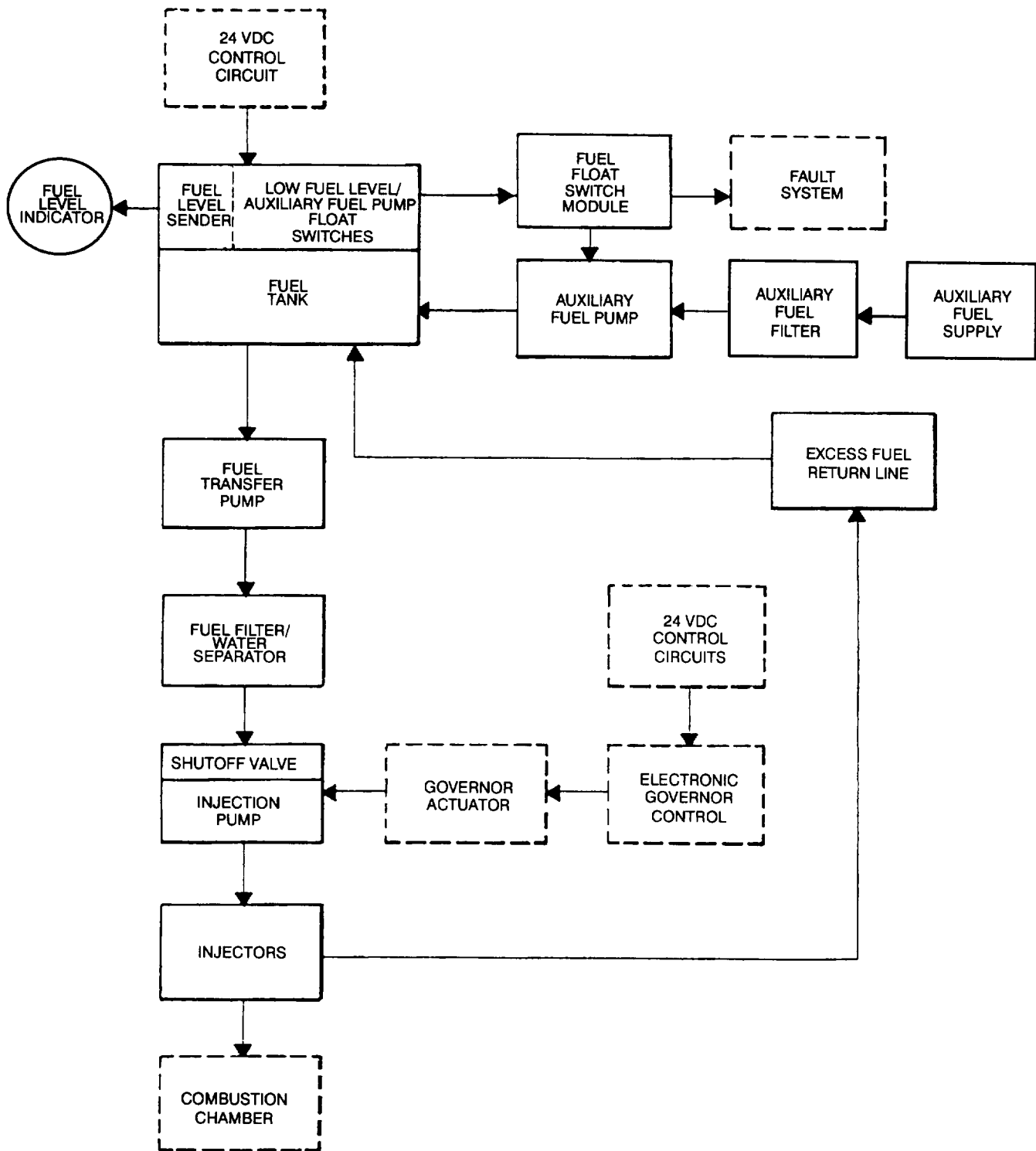

FIGURE 1-3. Generator Set Fuel System

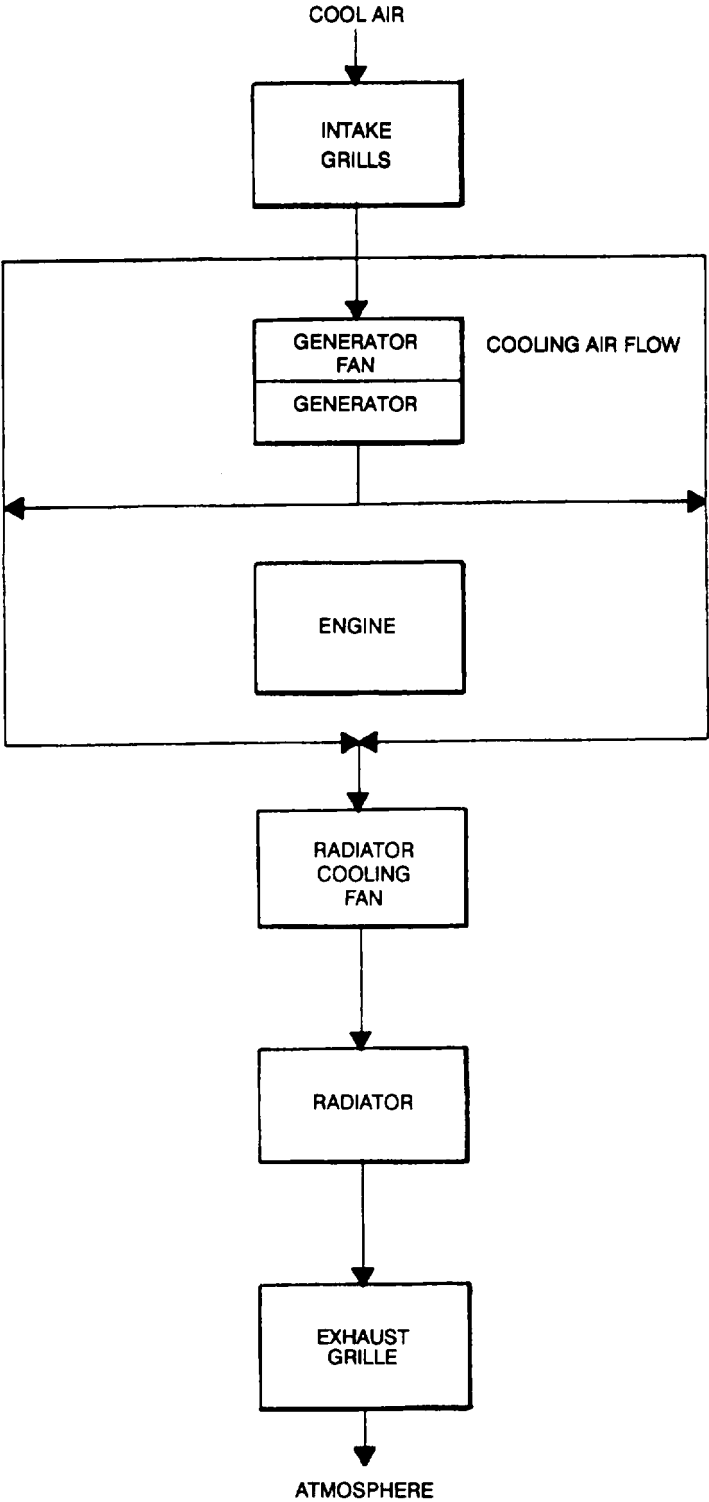

FIGURE 1-4. Generator Set Cooling System

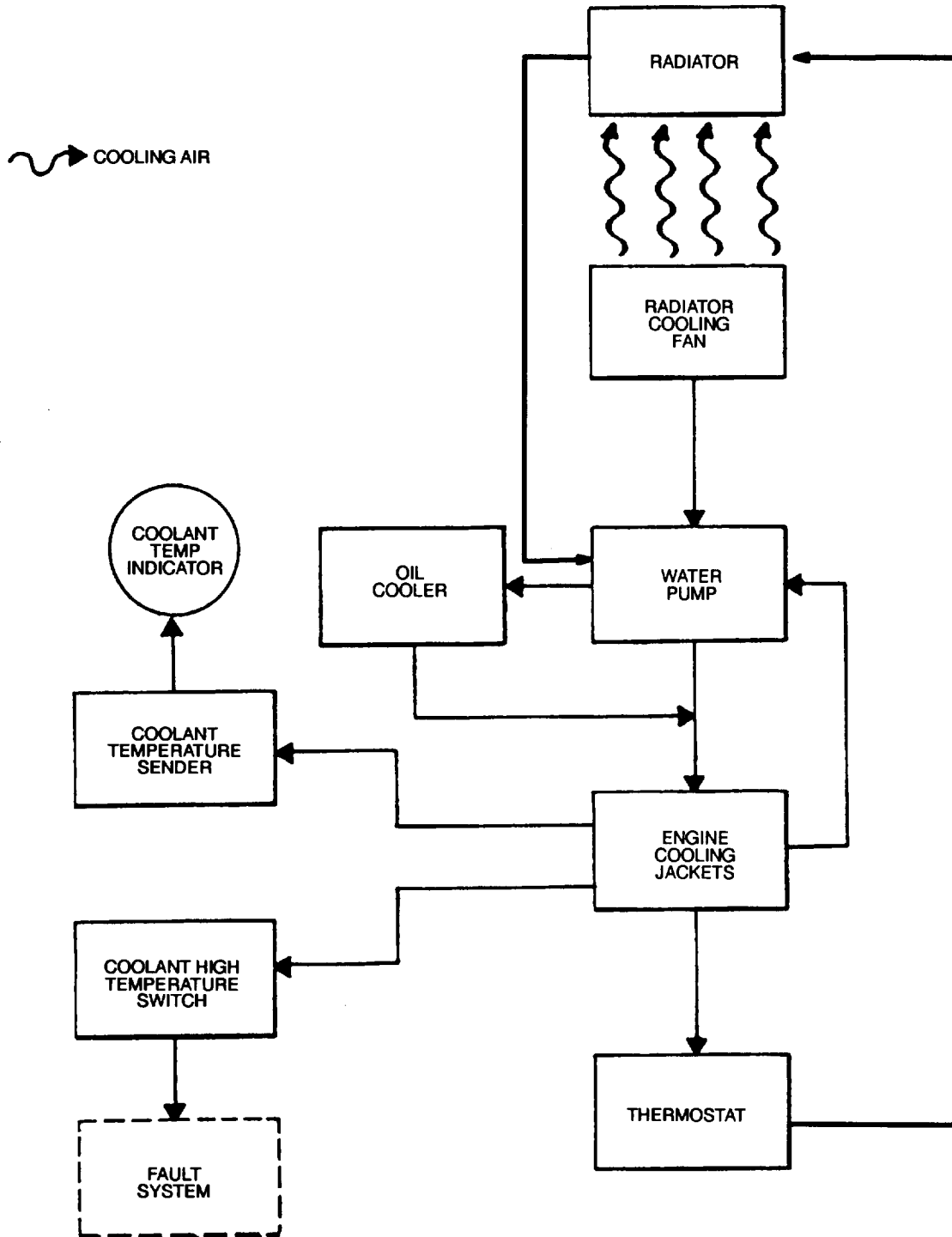

FIGURE 1-5. Engine Cooling System

1-12-4-3 A coolant high temperature switch in conjunction with the fault system provides automatic shutdown in the event that coolant temperature exceeds $225 \pm 5^\circ \text{ F}$ ($107 \pm 3^\circ \text{ C}$). The COOLANT TEMP. indicator displays the engine coolant temperature, from 120° F TO 240° F (49° C TO 116° C).

1-12-44 The water pump also circulates coolant through the engine oil cooler to cool the engine oil.

1-12-5 Engine Lubrication System.

1-12-5-1 The Engine Lubrication System (FIGURE 1-6) consists of an oil pan, dipstick, pump, oil cooler, oil sample valve, oil pressure sender, OIL PRESSURE indicator, low oil pressure switch and filter.

1-12-5-2 The oil pan is a reservoir for engine lubricating oil. The dipstick indicates oil level in the pan. The oil level can be checked during engine operation. One side of the dipstick is used for checking oil level while the engine is running and the other side is used while the engine is shutdown. The pump draws oil from the oil pan through a screen removing large impurities. The oil then passes through tubes in the oil cooler. Engine coolant from the engine cooling system is circulated around the tubes to cool the oil. From the cooler, oil passes through a spin-on type filter where small impurities are removed. From the filter, oil is distributed to the engine and turbocharger moving parts and then returns to the oil pan. The oil pressure sender located in the engine block senses oil pressure. The oil pressure is displayed on the OIL PRESSURE indicator. An Army Oil Analysis Program (AOAP) sample valve located in the block allows oil samples to be taken while the engine is operating. The low oil pressure switch, also located in the engine block, functions with the generator set fault system. The engine is automatically shut off if the oil pressure drops below $15+3 \text{ psi}$ ($103.4 \pm 20.7 \text{ kPa}$).

1-12-6 Engine Air Intake and Exhaust System.

1-12-6-1 The Engine Air Intake and Exhaust System (FIGURE 1-7) consists of an air cleaner assembly, intake manifold, ether supply tank, ether solenoid valve, ETHER switch, exhaust manifold turbocharger, crankcase breather filter, and muffler. The air cleaner assembly includes a dust collector, filter element, restriction indicator and dust evacuator valve.

1-12-6-2 Air is drawn into the dust collector and passes through the filter element. Airtime dirt is removed and trapped in the dust collector and filter element. Some dust can be removed from the dust collector by pinching the evacuator valve. The restriction indicator indicates when the filter should be serviced. Filtered air is drawn out of the filter through air intake tubes into the turbocharger where it is compressed and forced into the engine.

1-12-6-3 The engine exhaust gases are expelled into the exhaust manifold and ported to the turbine of the turbocharger. The turbine drives the turbocharger compressor which compresses the intake air. Exhaust gases discharged by the turbocharger are channeled into the muffler that deadens the sound of the exhaust gases. The gases pass from the muffler through the muffler outlet and are vented upward from the generator set housing. A cover, which is held open by the pressure of the exhaust gases during operation, closes over the exhaust port to prevent rain, water, or other foreign matter from entering the exhaust port when the set is not in use. The cover is easily removed for connection of an exhaust pipe for indoor operation.

1-12-64 Combustion gases which enter the crankcase are filtered through the crankcase breather filter to remove oil droplets and are then recycled through the intake manifold.

1-12-6-5 An ether supply system is provided to improve engine starting when outside ambient air temperature is below 40° F (4° C). The ether system includes an ether supply tank, ether solenoid valve, ETHER switch, and piping from the solenoid valve to the intake manifold. The ether system is activated by turning the MASTER SWITCH to START and holding the ETHER switch in the ON position.

1-12-7 Output Supply System.

1-12-7-1 The Output Supply System (FIGURE 1-8) consists of the AC generator, GROUND FAULT CIRCUIT INTERRUPTER (GFCI), CONVENIENCE RECEPTACLE, current transformer, AC voltage reconnection terminal board, AC circuit interrupter relay, load output terminals, AC CIRCUIT INTERRUPTER switch, kilowatt transducer, kilowatt meter (PERCENT POWER), AM-VM transfer switch, AC voltmeter (VOLTS AC), and ammeter (PERCENT RATED POWER).

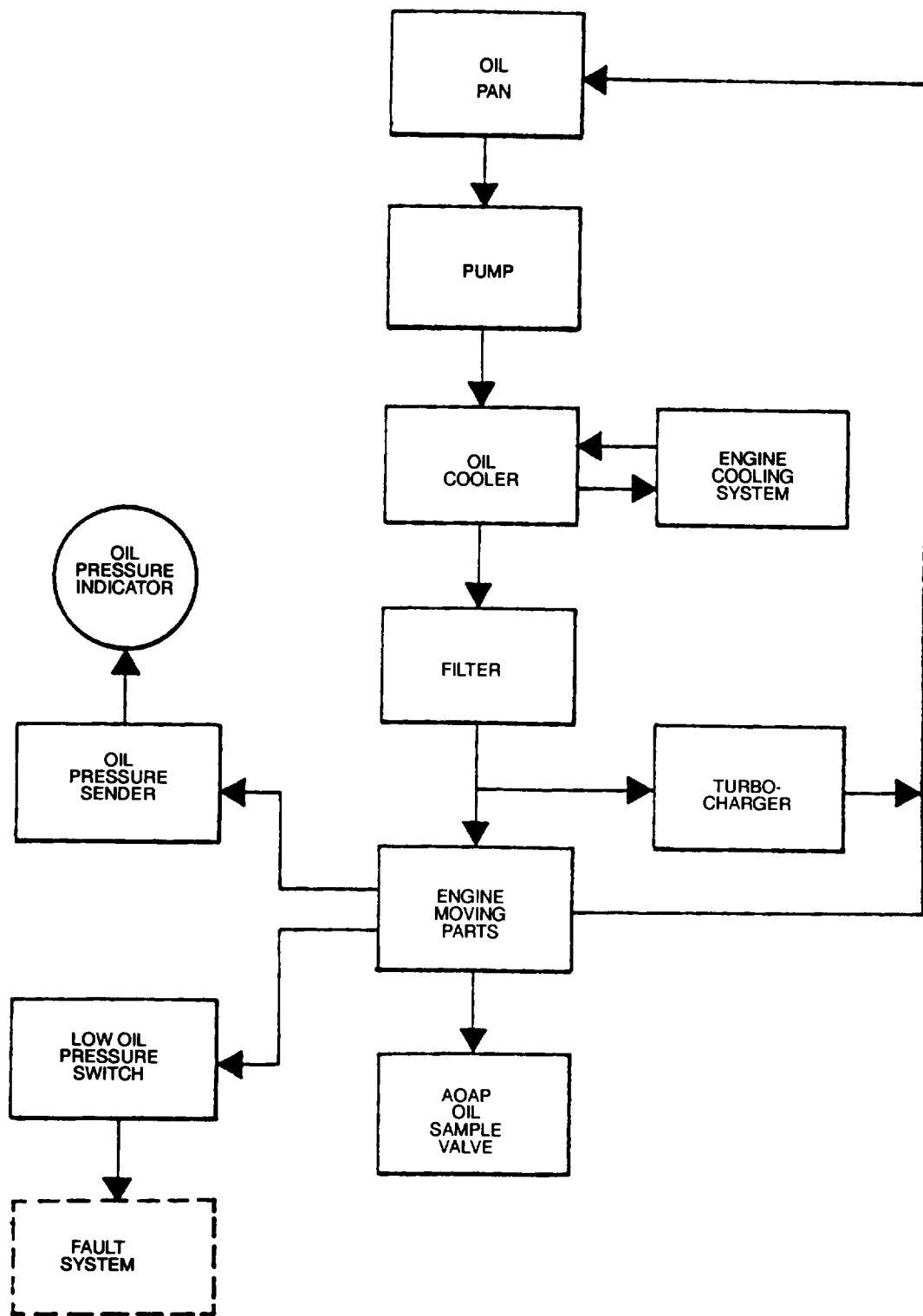

FIGURE 1-6. Engine Lubrication System

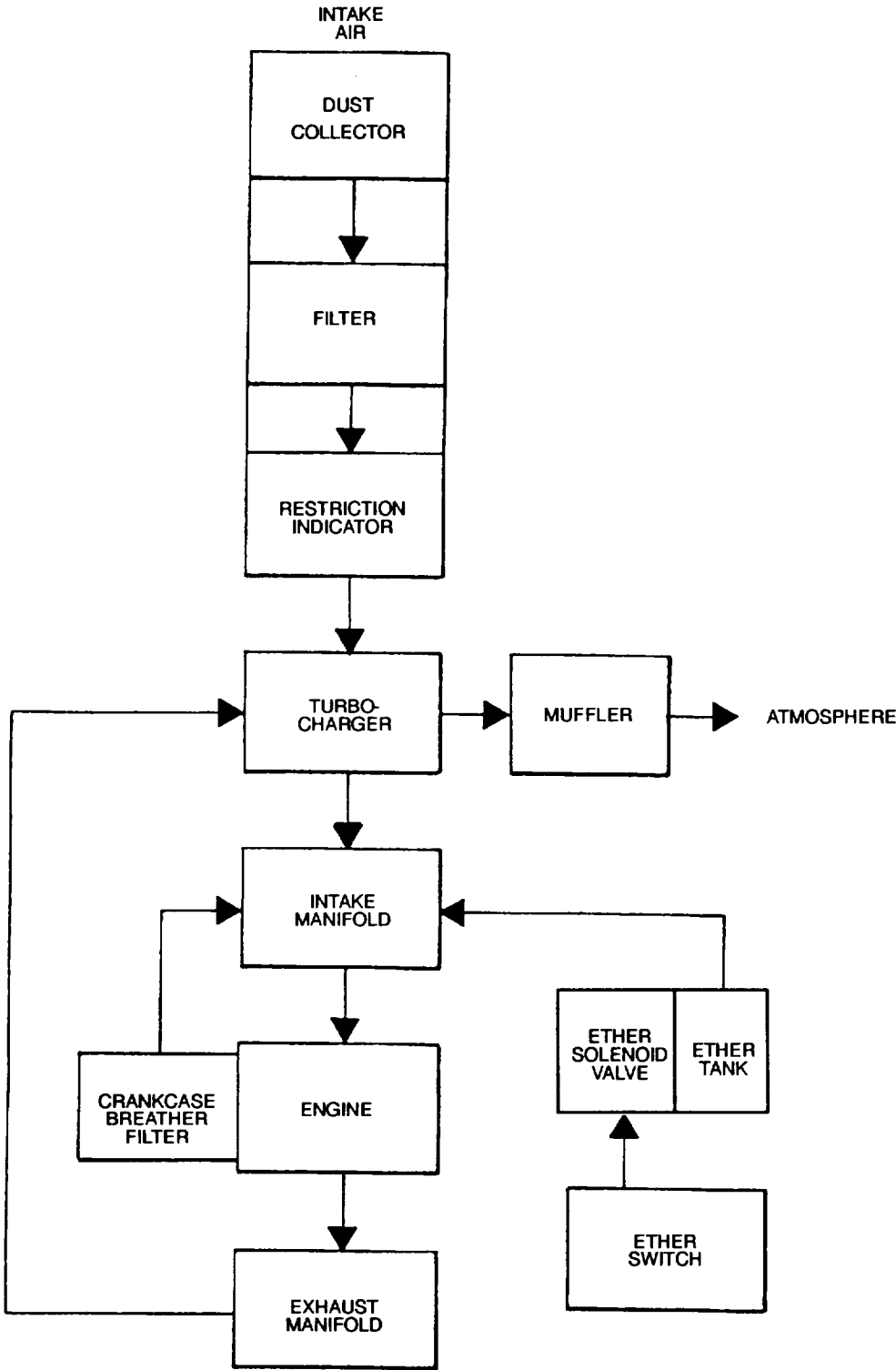

FIGURE 1-7. Engine Air Intake and Exhaust System

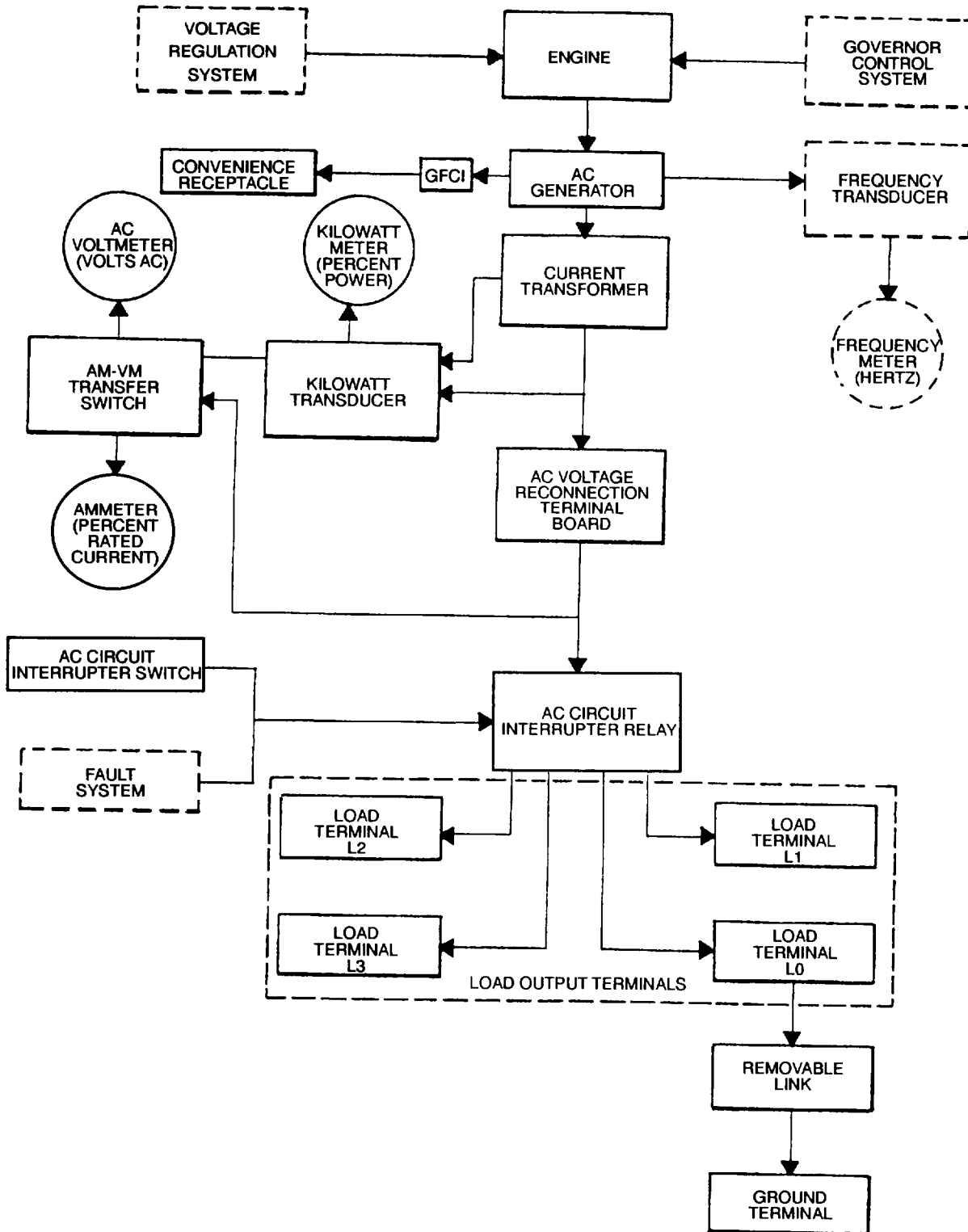

FIGURE 1-8. Output Supply System

1-12-7-2 Power created by the generator is supplied through the current transformer, AC voltage reconnection terminal board, and AC circuit interrupter relay to the load output terminals. The AC voltage reconnection terminal board allows configuration of the generator set for 120/208 volt connections or 240/416 volt connections. The AC CIRCUIT INTERRUPTER switch closes and opens the AC circuit interrupter relay. This enables or interrupts the power flow between the AC voltage reconnection terminal board and the load output terminals. The voltage regulation system (refer to paragraph 1-12-10) senses generator output voltage and provides a control signal to the generator exciter to maintain the desired generator output voltage. Generator output frequency is controlled by the governor control system (refer to paragraph 1-12-9) and is read on the frequency meter (HERTZ). The current transformer provides a reduced current signal to the kilowatt transducer and ammeter (PERCENT RATED CURRENT). The kilowatt transducer and kilowattmeter (PERCENT POWER) provide an indication of the power being used by the load. The ammeter (PERCENT RATED CURRENT) indicates the percent of rated current being supplied to the load. The position of the AM-VM transfer switch selects the output load terminals from which current and voltage is measured. The AC circuit interrupter relay will open and disconnect the load whenever any of the following faults occur: reverse power, undervoltage, overload, or short circuit.

1-12-7-3 The AC generator also provides 120 VAC power to the CONVENIENCE RECEPTACLE through the GROUND FAULT CIRCUIT INTERRUPTER.

1-12-8 Generator Set Controls.

1-12-8-1 Engine Starting System.

1-12-8-1-1 Engine starting is accomplished primarily with two 12-volt batteries, connected in series to provide 24 VDC power, and a starter (FIGURE 1-9). The starter includes a cranking motor and a solenoid. To permit engine starting, the DC CONTROL POWER circuit breaker must be pushed in, the DEAD CRANK switch must be in the NORMAL position and the BATTLE SHORT switch must be in the OFF position. In addition, any ENGINE SHUTDOWN fault previously registered on the malfunction indicator panel must have been corrected and the malfunction indicator panel must have been reset.

When the MASTER SWITCH is then placed in the START position, the starting circuits supply 24 VDC power to the starter. As the engine accelerates to approximately 900 rpm, the starting circuits disconnect power from the starter.

1-12-8-1-2 When the MASTER SWITCH is first moved to the START position, the various instrument and control circuits are energized. The Engine Starting System includes two control circuits. One starting control circuit energizes the start relay through closed switch contacts of the engine fault relay and the BATTLE SHORT switch. The other starting control circuit energizes the cranking relay coil through closed contacts of the crank disconnect switch and the start relay. (The crank disconnect switch is an integral part of the electronic governor control.) With the cranking relay energized, power passes from the batteries through closed contacts of the Cranking relay to energize the starter solenoid. With the starter solenoid energized, power passes from the starter solenoid to the cranking motor. The cranking motor then cranks the engine. Engine speed is sensed by the magnetic pickup which sends a signal to the electronic governor control. As the engine accelerates to approximately 900 rpm, the signal from the magnetic pickup causes the crank disconnect switch to open one set of contacts and close another set of contacts. The open contacts break the circuit to the cranking relay and stop engine cranking. The closed contacts cause the field flash relay to be energized. When the MASTER SWITCH is moved to one of the two RUN positions, both starting control circuits are deenergized. The other generator set control and instrument circuits remain energized.

1-12-8-1-3 The engine may be cranked without starting by use of the DEAD CRANK switch. With the DEAD CRANK switch in the CRANK position, the cranking relay coil is energized to initiate engine cranking without energizing any other starting or control functions.

1-12-8-1-4 The generator set can be started without batteries by connecting an external 24 VDC power source to the NATO SLAVE RECEPTACLE. The generator set can also supply starting power to another set through the NATO SLAVE RECEPTACLE.

1-12-8-1-5 The batteries are charged by the battery charging alternator that is belt driven by the engine. The BATTERY CHARGE ammeter indicates the charge/discharge rate of the batteries, from -10 Amps to +20 Amps. A shunt provides a DC voltage signal, which is directly proportional to the actual battery current flow, to the BATTERY CHARGE ammeter. Normal operating indication on the BATTERY CHARGE ammeter depends on the state of the charge in the batteries. A low charge, which may exist immediately after engine starting, will cause a high reading (needle moves toward CHARGE area). When the charge in the batteries has been restored, the indicator moves near zero. The battery charging system is protected from reverse polarity in the battery connections by a fuse and diode.

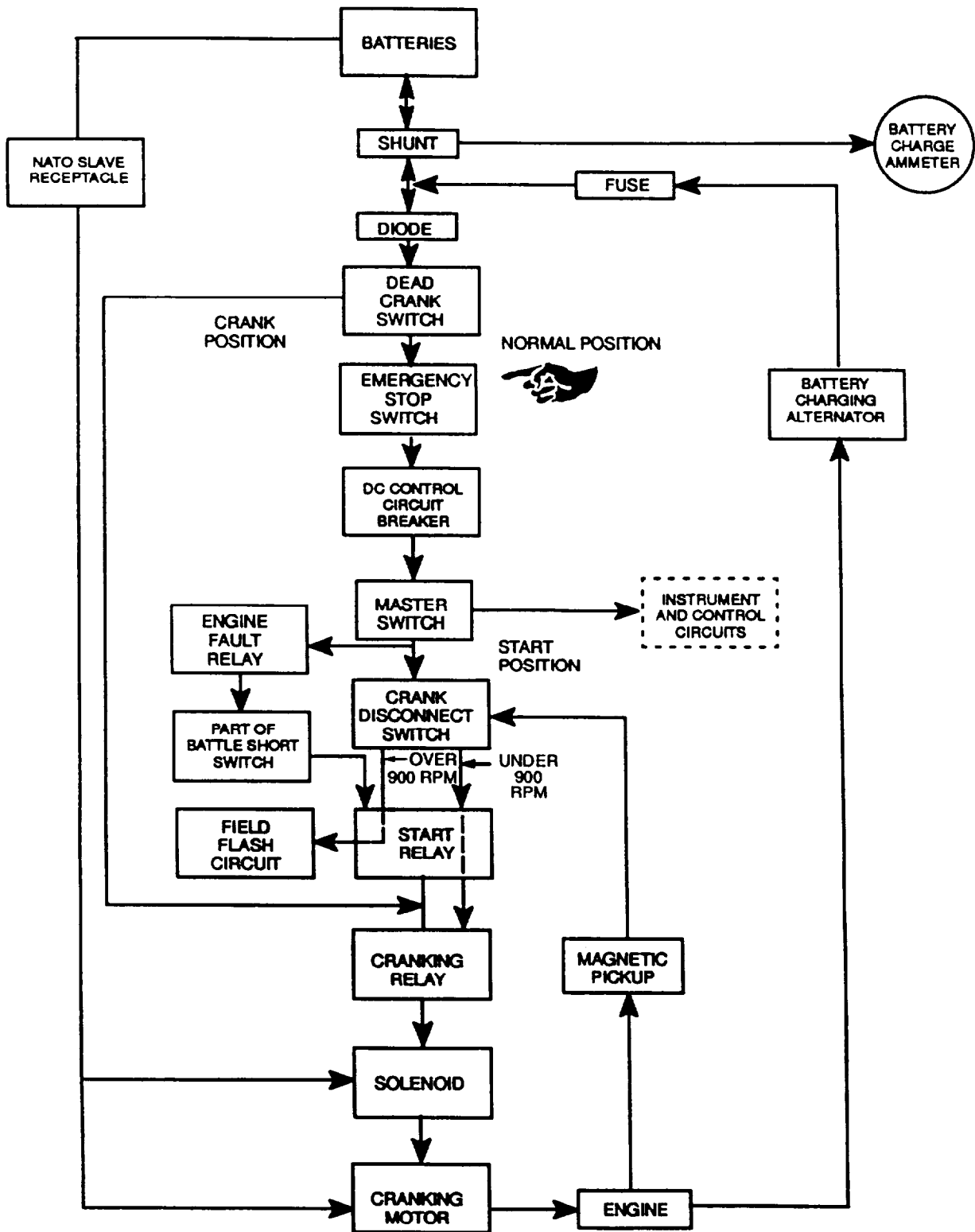

FIGURE 1-9. Engine Starting System

1-12-8-2 Field Flash. When the engine reaches sufficient speed (900 rpm), the magnetic pickup causes a set of contacts in the crank disconnect switch to close and energize the field flash relay. This circuit provides current to the exciter field windings which sets up an electromagnetic field. The field current is necessary for the set to generate sufficient voltage for the voltage regulator (FIGURE 1-11) to begin controlling the output voltage of the generator set. The field flash circuit is maintained until the MASTER SWITCH is released from the START position.

1-12-8-3 Operation. Placing the MASTER SWITCH in the PRIME& RUN or PRIME & RUN AUX FUEL positions keeps the electronic governor control (FIGURE 1-10) energized, and fuel will be supplied to the fuel injection pump as long as no fault condition exists. During operation, the operator should periodically check the set's instruments to ensure they are reading in the normal operating ranges. The VOLTAGE and FREQUENCY potentiometers are adjusted as required to maintain desired frequency and voltage output.

1-12-8-4 Applying the Load. The load is applied by placing the AC CIRCUIT INTERRUPTER switch in the CLOSED position. This is a momentary contact switch that returns to the neutral, or center position. The AC circuit interrupter relay is energized by this momentary contact and a holding circuit keeps it closed, bringing the load on line.

1-12-8-5 Shutdown.

1-12-8-5-1 The AC circuit interrupter relay is disengaged by placing the AC CIRCUIT INTERRUPTER switch in the OPEN position. This is a momentary contact switch which will break the AC circuit interrupter relay holding circuit and then return to the neutral, or center position, disconnecting the load from the line.

1-12-8-5-2 The generator set should remain running for five minutes after disconnecting the load. During this five minute interval, oil circulates through the turbocharger, cooling it enough to be shutdown.

1-12-8-5-3 When the MASTER SWITCH is placed in the OFF position all power is removed from the control circuit and the engine will stop.

1-12-8-5-4 The EMERGENCY STOP switch will remove power from the control circuit by energizing the engine fault relay. This will cause the engine to shut down. The EMERGENCY STOP switch is not to be used as an alternative for routine shutdown procedures. When the generator set is stopped using the EMERGENCY STOP switch, some circuits remain energized causing a drain on the batteries until the MASTER SWITCH is placed in the OFF position.

1-12-8-6 Paralleling.

1-12-8-6-1 The generator set is capable of being operated in parallel with one other set of the same model number. This capability is provided by the PARALLELING RECEPTACLE, paralleling cable, the LOAD SHARING ADJUST and REACTIVE CURRENT ADJUST rheostats, two SYNCHRONIZATION LIGHTS, the UNIT-PARALLEL switch, reverse power relay, voltage sensing relay, droop current transformer, and the permissive paralleling relay.

1-12-8-6-2 The paralleling cable is used to interconnect the governor and voltage regulator paralleling circuits of the two sets. The UNIT-PARALLEL switch is used to select parallel operation. Voltage and frequency of the two generator sets are synchronized by adjusting each set's VOLTAGE and FREQUENCY controls. Phase synchronization is indicated by the SYNCHRONIZATION LIGHTS. The reverse power relay serves as a safety device that opens the AC CIRCUIT INTERRUPTER when one of the sets fail to produce power and begins to receive power from the other set. The reverse power relay operates when the power received exceeds 20% of set rating. The load sharing adjust and reactive current adjust rheostats, and the droop current transformer are used to adjust power and current for load sharing at the factory or by maintenance. No adjustment of the rheostats is required for normal operation. The permissive paralleling relay monitors the voltage phase relationship and prevents the AC circuit interrupter relay from closing when the units are not properly synchronized. The voltage sensing relay senses the operating voltage range, 120/208 volts or 240/416 volts, and switches an additional resistor to each of the SYNCHRONIZATION LIGHT circuits during 240/416 volts operation to protect the lights.

1-12-9 Governor Control System.

1-12-9-1 The Governor Control System (FIGURE 1-10) includes the electronic governor control, governor actuator, magnetic pickup, load measuring unit, frequency transducer, FREQUENCY meter (HERTZ), kilowatt transducer, fuel injection pump, FREQUENCY SELECT switch, and FREQUENCY adjust potentiometer.

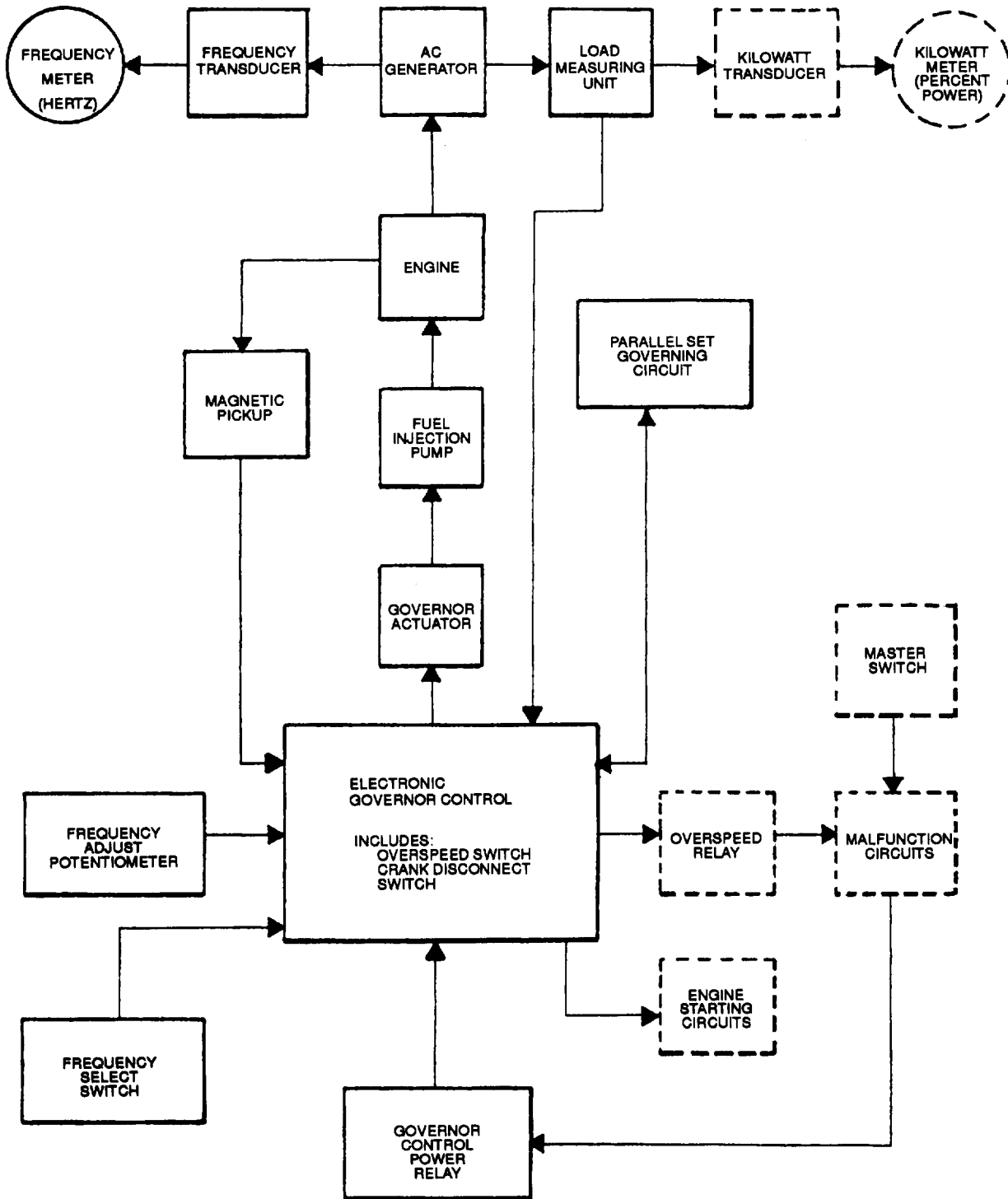

FIGURE 1-10. Governor Control System

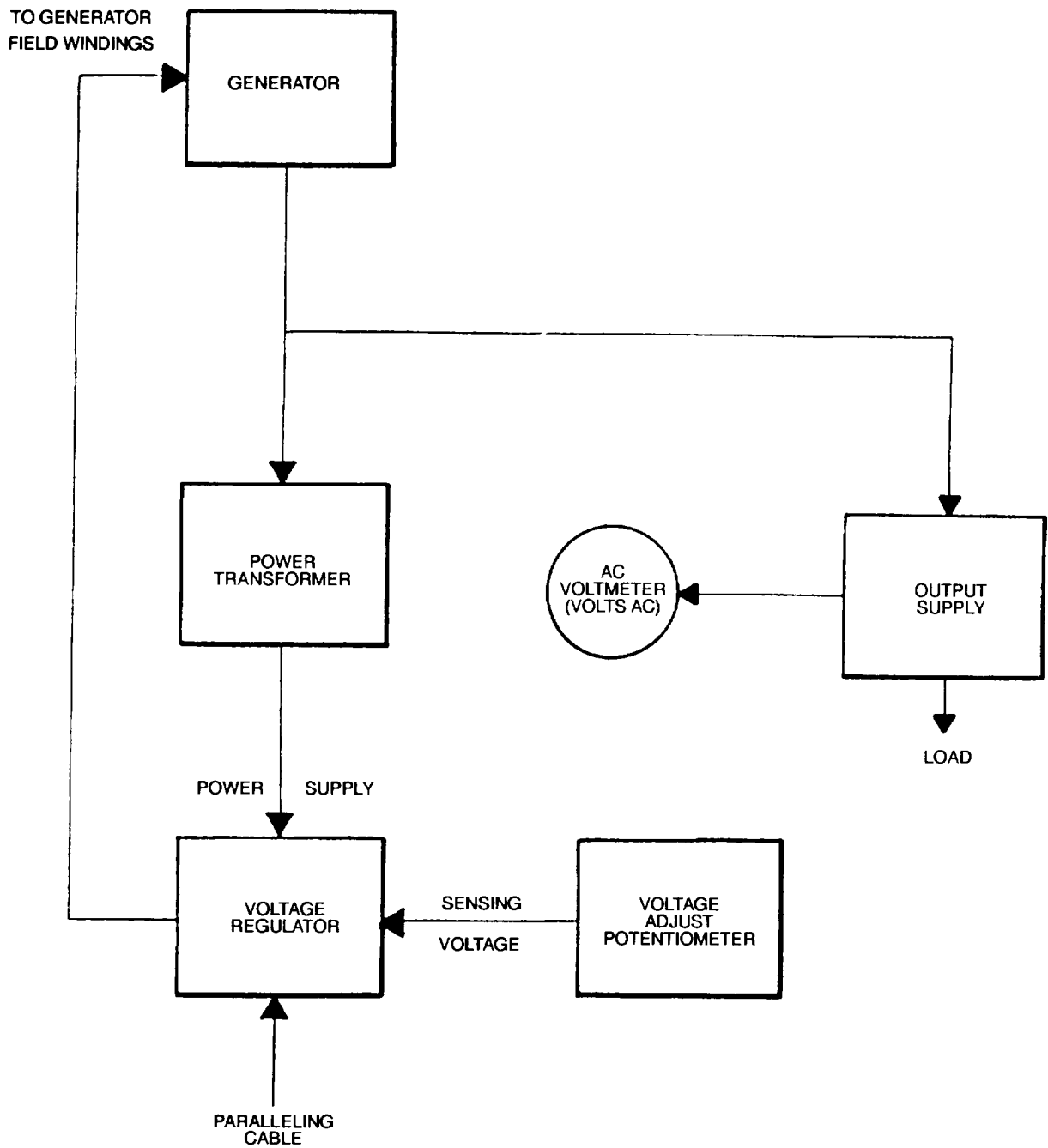

FIGURE 1-11. Voltage Regulation System

ARMY TM 9-61155-644-24

AIR FORCE TO 35C2-3-446-12

MARINE CORPS TM 09249A/09246A-24/2

1-12-9-2 The governor actuator is a linear electromechanical actuator which controls the output of the fuel injection pump in response to the electrical input from the electronic governor control. The FREQUENCY adjust potentiometer, located on the control panel and adjusted by the operator, provides a signal representing the desired engine speed/generator frequency to the electronic governor control. A signal representative of the actual engine speed/generator frequency is sent to the electronic governor control by the magnetic pickup. Any change in engine speed from that selected by the operator, as sensed by the magnetic pickup, causes the electronic governor control to increase or decrease the fuel injection pump output to maintain the desired speed. The load measuring unit senses changes in external load demand and provides a change signal to the electronic governor control allowing the control to start its response prior to any actual change in engine speed. The generator set frequency and power output are indicated by the FREQUENCY meter (HERTZ) and the kilowattmeter (PERCENT POWER) on the control panel. The FREQUENCY SELECT switch is used to set the generator for 50 hertz or 60 hertz operating frequencies (MEP-805A).

1-12-9-3 The electronic governor control also contains the engine overspeed switch (Fault System) and the crank disconnect switch (Engine Starting System). These switches function as a result of input from the magnetic pickup.

1-12-9-4 Twenty-four VDC power is supplied to the electronic governor control through the governor control power relay. The governor control power relay is controlled by the fault system. The electronic governor controls of two generator sets operating in parallel are interconnected by the paralleling cable.

1-12-10 Voltage Regulation System. The Voltage Regulation System (FIGURE 1-11) consists of the voltage regulator, VOLTAGE adjust potentiometer and power transformer. The voltage regulator senses and controls the generator output voltage which is operator adjustable within the design limits by use of the VOLTAGE adjust potentiometer. The power transformer provides operating power to the voltage regulator. The output voltage is indicated by the AC voltmeter (VOLTS AC) on the control panel.

1-13 LOCATION AND DESCRIPTION OF MAJOR COMPONENTS.

NOTE

All locations (FIGURE 1-12) referenced herein are given facing the control box side (rear) of the generator set.

1-13-1 Malfunction Indicator Panel (1). The malfunction indicator panel is located to the left of the control panel assembly. It indicates malfunctions of the generator set components.

1-13-2 Control Panel Assembly (2). The generator set control panel is located at the rear of the generator set and contains controls and instruments for operating the engine and the generator.

1-13-3 Muffler (3). The muffler and exhaust tubing are connected to the turbocharger on the engine. The exhaust exits from the top of the generator set housing. Gases are exhausted upward.

1-13-4 NATO SLAVE RECEPTACLE (4). The NATO SLAVE RECEPTACLE is located on the right side (front) of the generator set. It is a NATO receptacle used for remote battery connection.

1-13-5 Fan Belt (5). The fan belt is located in the engine compartment on the front of the engine. The belt drives the fan, water pump, and the battery charging alternator.

1-13-6 Battery Charging Alternator (6). The battery charging alternator is located on the right side of the engine. It is capable of maintaining the batteries in a state of full charge in addition to providing the required 24 VDC control power.

1-13-7 Oil Filter (7). The oil filter is located in the engine compartment on the right side. The filter removes impurities from the engine lube oil.

1-13-8 Dipstick (8). The dipstick is located in the engine compartment on the right side. The dipstick shows the lube oil level in the engine crankcase.

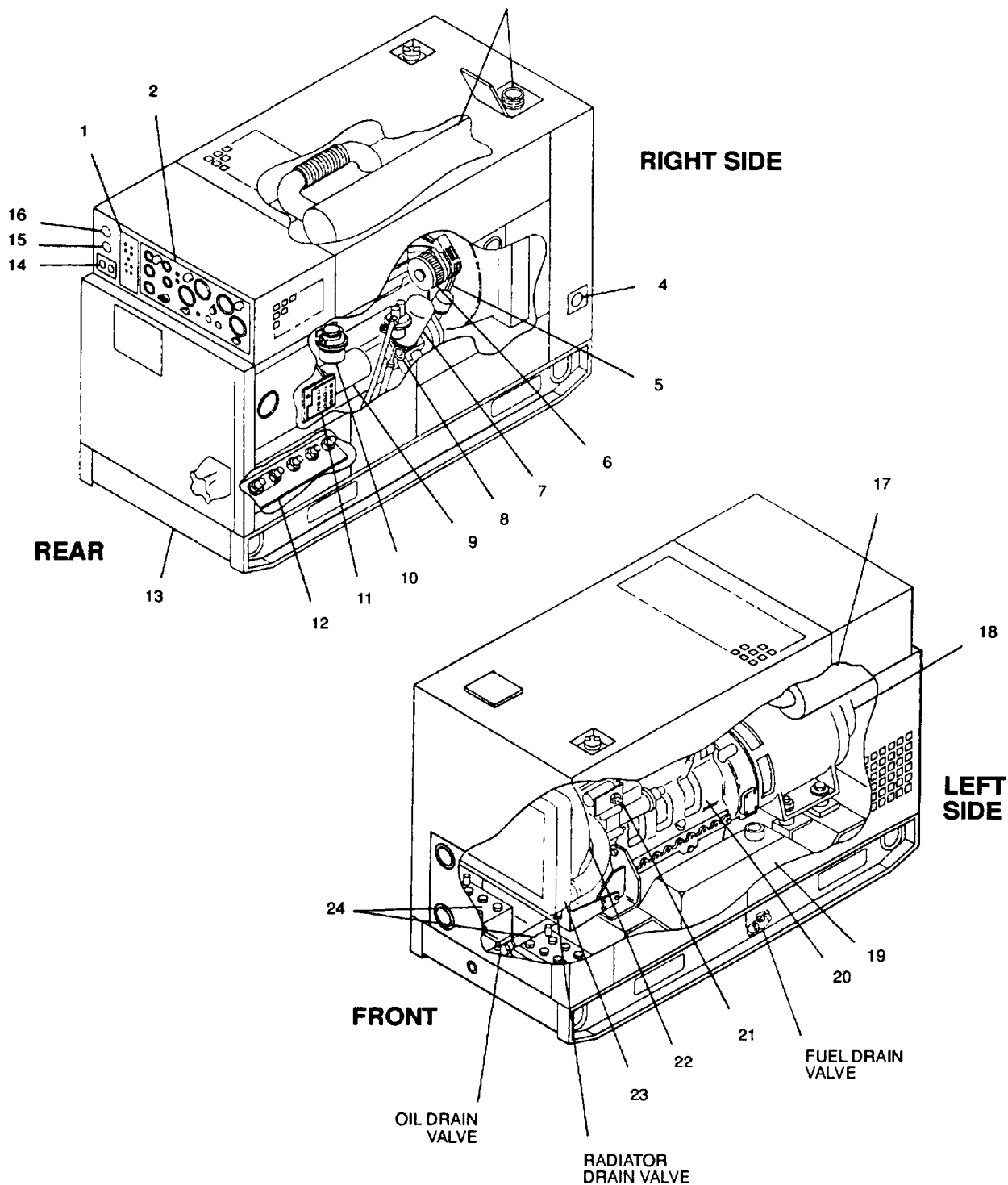

FIGURE 1-12. Generator Set Components

ARMY TM 9-6115-644-24

AIR FORCE TO 35C2-3-446-12

MARINE CORPS TM 09249A/09246A-24/2

1-13-9 Starter (9). The starter is located on the right side of the engine. The electric cranking motor mechanically engages the engine flywheel in order to start the diesel engine.

1-13-10 Fuel Filter/Water Separator (10). The fuel filter/water separator is located in the engine compartment on the right side. The element removes impurities and water from the diesel fuel.

1-13-11 AC Voltage Reconnection Terminal Board (11). The AC voltage reconnection terminal board is located on the right side (rear) of the generator set. The board allows reconfiguration from 120/208 to 240/41 6 VAC output.

1-13-12 Load Output Terminal Board (12). The load output terminal board is located on the right side (rear) of the generator set. Four AC output terminals are located on the board. They are marked L1, L2, L3 and LO. A fifth terminal, marked GND, is located next to the output terminals and serves as equipment ground for the generator set. A removable, solid copper bar is connected between the LO and GND terminals.

1-13-13 Skid Base (13). The skid base supports the generator set. It has fork lift access openings and cross members for short distance movement. The skid base has provisions in the bottom for installation of the generator set on a trailer.

1-13-14 CONVENIENCE RECEPTACLE (14). The CONVENIENCE RECEPTACLE is a 120 VAC receptacle used to operate small plug in type equipment.

1-13-15 PARALLELING RECEPTACLE (15). The PARALLELING RECEPTACLE is used to connect the paralleling cable between two generator sets of the same size and mode to operate in parallel.

1-13-16 Diagnostic Connector (16). The diagnostic connector is a multi-pin plug that is wired to specific points in the generator set electrical system to enable monitoring and troubleshooting of the generator set operation at a single location.

1-13-17 Air Cleaner Assembly (17). The air cleaner assembly is located on the left side behind the air cleaner access door. It consists of a dry-type, disposable paper filter and canister. The air cleaner assembly features a dust collector which traps large dust particles. The air cleaner assembly has a restriction indicator which will pop up during operation when the air cleaner requires servicing.

1-13-18 AC Generator (18). The AC generator is a single bearing, drip-proof, synchronous, brushless, three phase, air-cooled generator. The generator is coupled directly to the rear of the diesel engine.

1-13-19 Fuel Tank (19). The 23 gallon (87.1 liters) fuel tank is located in the front of the generator set below the engine and between the skid base side members. The fuel tank has sufficient capacity to enable the generator set to operate for at least 8 hours without refueling.

1-13-20 Engine (20). The generator is powered by a four cylinder, four cycle, fuel injected, turbocharged, liquid-cooled diesel engine which occupies the front half of the generator set. The engine is also equipped with a fuel filter/water separator, oil filter, and an air cleaner assembly. Protection devices automatically stop the engine during conditions of high coolant temperature, low oil pressure, no fuel, overspeed, and overvoltage.

1-13-21 DEAD CRANK Switch (21). The DEAD CRANK switch is located in the engine compartment on the left side. The switch allows the engine to be turned over without starting for maintenance purposes.

1-13-22 Water Pump (22). The water pump is located in the engine compartment on the front of the engine. The pump circulates the engine coolant through the engine block and the radiator.

1-13-23 The radiator (23). The radiator is located at the front of the generator set. It acts as a heat exchanger for the engine coolant.

1-13-24 Batteries (24). Two batteries are located at front of the generator set. The batteries are electrolyte serviceable, lead acid, 12 VDC type. After starting, the generator set is capable of operating with batteries removed. A diode, located behind the control panel, protects the generator set if the batteries are incorrectly connected.

CHAPTER 2

UNIT MAINTENANCE INSTRUCTIONS

Section I. SERVICE UPON RECEIPT OF EQUIPMENT

2-1 INSPECTION AND DERVICING THE EQUIPMENT.

This section provides information and guidance for inspecting, servicing and installing the generator set under normal conditions.

2-1-1 Inspection.

- a. Unpack and inventory all end item components for serviceability.
- b. Check that all packing materials have been removed.
- c. Check generator set identification plate for proper identification.
- d. Inspect generator set exterior for shipping damage.
- e. Open battery compartment access door and inspect batteries for damage.
- f. Check battery cables for proper polarity connection, damage, and loose connections.
- g. Open control panel access door and check panel for damage.
- h. Lower control panel and check electrical components for damage or loose connections.
- i. Raise control panel and secure fasteners.
- j. Check air cleaner assembly for external damage and exhaust opening for obstruction.
- k. Check fan belt for looseness and ensure it is not frayed or cracked.
- l. Inspect generator set for loose or missing mounting hardware or damaged or missing parts.

NOTE

Dipstick is marked indicating that oil level can be checked and oil added when engine is running or stopped. Make sure the correct side of dipstick is checked.

- m. Check oil level. As required, drain preservative from engine and fill with proper lubricating oil, refer to paragraph 2-1-2-4.
- n. Unpack grounding rod from inside left engine access door, parallel cable and auxiliary fuel hose from storage box. Inspect each item for damage and accountability.

2-1-2 Service.

2-1-2-1 Batteries.

For battery servicing see TM 9-6140-200-14.

2-1-2-2 Radiator.

WARNING

Do not operate generator set while servicing radiator. Damage to equipment or personal injuries may result.

- a. Remove radiator cap.
- b. Check that radiator drain valve is dosed, refer to FIGURE 1-12.
- c. Fill radiator with proper coolant/antifreeze in accordance with TABLE 2-1. Fill radiator to a level two inches below fill opening.
- d. Remove overflow bottle cap.
- e. Fill overflow bottle to "COLD" level.
- f. Install overflow bottle and radiator caps.
- g. After 30 minutes of operation check coolant/antifreeze level at overflow bottle. Add coolant/antifreeze as required to overflow bottle.

2-1-2-3 Fuel Tank.

WARNING

The fuels used in this generator set are highly explosive. Do not smoke or use open flames when performing maintenance. Fire or explosion could cause serious injury or death.

- a. Check that fuel drain valve is dosed, refer to FIGURE 1-12.

WARNING

Hot refueling of generator set while operating presents a safety hazard and should not be attempted. Hot engine surfaces and sparks produced from the engine and generator circuitry are possible sources of ignition. Severe injury or death could occur.

- b. Remove fuel tank filler cap.

TABLE 2-1. Coolant

AMBIENT TEMPERATURE	RADIATOR COOLANT	RATIO
+40°F TO +120°F (4°C TO 49°C)	WATER: MIL-A-53009 INHIBITOR, CORROSION	35:1
-25°F TO +120°F (-32°C TO 49°C)	WATER: MIL-A-46153 ANTIFREEZE	1:1
-25°F TO +120°F (-32°C TO 49°C)	MIL-A-11755 ANTIFREEZE	N/A

WARNING

When filling the fuel tank, maintain metal-to-metal contact between filler nozzle and fuel tank opening. Failure to follow this warning could result in explosion, severe personal injury or death.

- c. Fill fuel tank with fuel type in accordance with TABLE 2-2. Fuel tank capacity is 23 gallons (87.1 liters).
- d. Install fuel tank filler cap.

2-1-2-4 Lubricating Oil.

- a. Place suitable container under oil drain plug and remove plug.
- b. Open battery access door, and open oil drain valve (FIGURE 1-12) and drain oil.

NOTE

Dipstick is marked indicating that oil level can be checked and oil added when engine is running or stopped. Make sure the correct side of dipstick is checked.

- c. Close oil drain valve and remove oil fill cap.
- d. Fill engine with proper engine lubricating oil in accordance with TABLE 2-3 to FULL mark on dipstick. Lubrication system capacity is 15 quarts (14.2 liters).
- e. Install oil fill cap.
- f. Close battery access door.

TABLE 2-2. Fuel

AMBIENT TEMPERATURE	DIESEL FUEL
+20°F TO +120°F (-6°C TO 49°C)	VV-F-800 GRADE DF-2, JP4, JP5, OR JP8
0°F TO +20°F (-17°C TO -6°C)	VV-F-800 GRADE DF-1, JP4, JP5, OR JP8
-25°F TO 0°F (-32°C TO -17°C)	VV-F-800 GRADE DF-1
-25°F TO 0°F (-32°C TO -17°C)	VV-F-800 GRADE DF-A

TABLE 2-3. Lubricating Oil

AMBIENT TEMPERATURE	LUBRICATING OIL
+20°F TO +120°F (-6°C TO 49°C)	MIL-L-2104 OE HDO-30 or OE HDO-15/40
0°F TO +20°F (-17°C TO -6°C)	MIL-L-2104 OE HDO-10
-25°F TO 0°F (-32°C TO -17°C)	MIL-L-46167

2-2 GENERATOR SET INSTALLATION.

2-2-1 General.

WARNING

Exhaust discharge contains deadly gases. Do not operate generator sets in enclosed areas unless exhaust discharge is properly vented outside. Failure to observe this warning could result in severe personal injury or death due to carbon monoxide poisoning.

- a. Ensure that installation site is as level as possible.
- b. Provide adequate ventilation to prevent recirculation of hot air exhausted from generator set.
- c. Refer to FIGURE 2-1 for base mounting measurements.

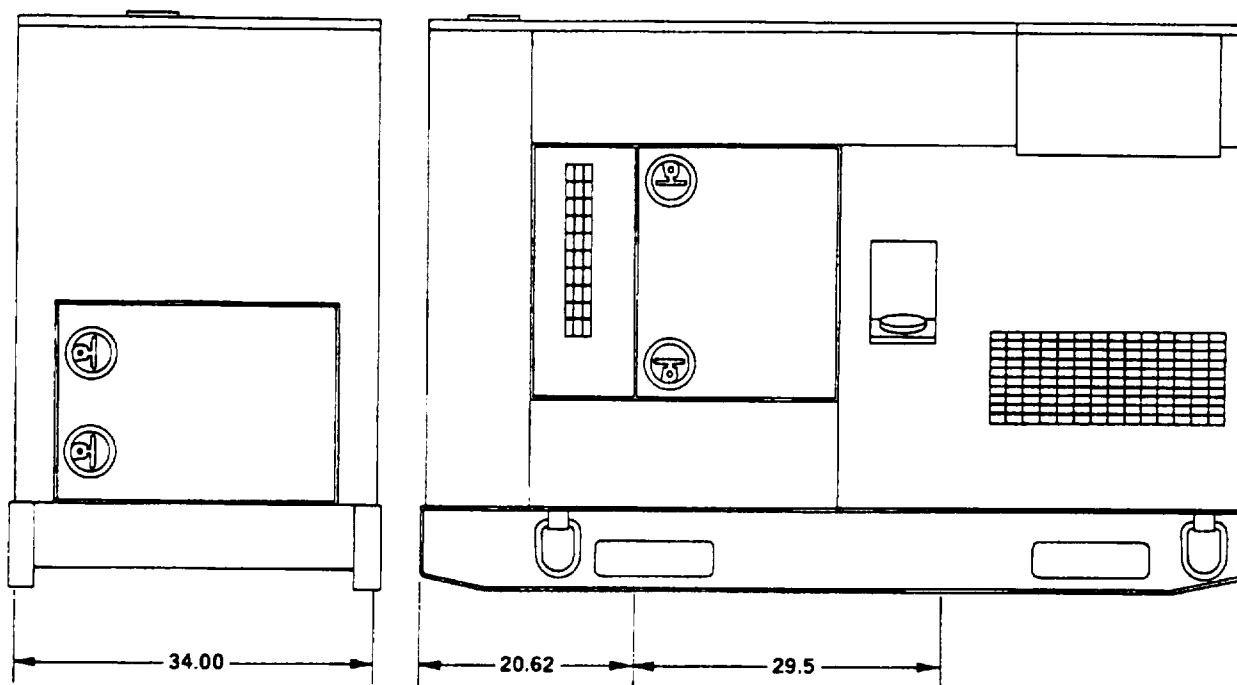

FIGURE 2-1. Base Mounting Measurements

2-2-2 Outdoor Installation.

- a. Make use of natural protective barriers.
- b. Allow space on all sides for service and maintenance. Refer to FIGURE 2-2 for minimum clearance measurements.
- c. Ensure that site soil is firm and well drained.
- d. Use planks or other material for support in areas where soil will not support the generator set.

2-2-3 Indoor Installation.

WARNING

Exhaust discharge contains deadly gases. Do not operate generator sets in enclosed areas unless exhaust discharge is properly vented outside. Failure to observe this warning could result in severe personal injury or death due to carbon monoxide poisoning.

CAUTION

Never position generator set with the air inlets near a wall or other object that interferes with tooting air circulation, damage to equipment could occur.

- a. Provide ducts and vents to outside of building if good supply of cooling air is not available.
- b. Make air intake and outlet openings in building same size or larger as those on the generator set.
- c. Install a gas tight metal pipe from exhaust pipe of generator set to outside of building.

NOTE

Make exhaust pipe extension as short and straight as possible with only one 90 degree bend, if needed.

- d. Ensure that inside diameter of exhaust pipe extension is as large or larger than generator exhaust pipe.

WARNING

Hot exhaust gases can ignite flammable materials. Failure to observe this warning could result in severe personal injury or death.

- e. Provide for harmless discharge of hot gases and sparks. Do not direct exhaust into area containing flammable materials.

WARNING

If not shielded, hot exhaust pipe can ignite flammable wall materials. Failure to observe this warning could result in severe personal injury or death.

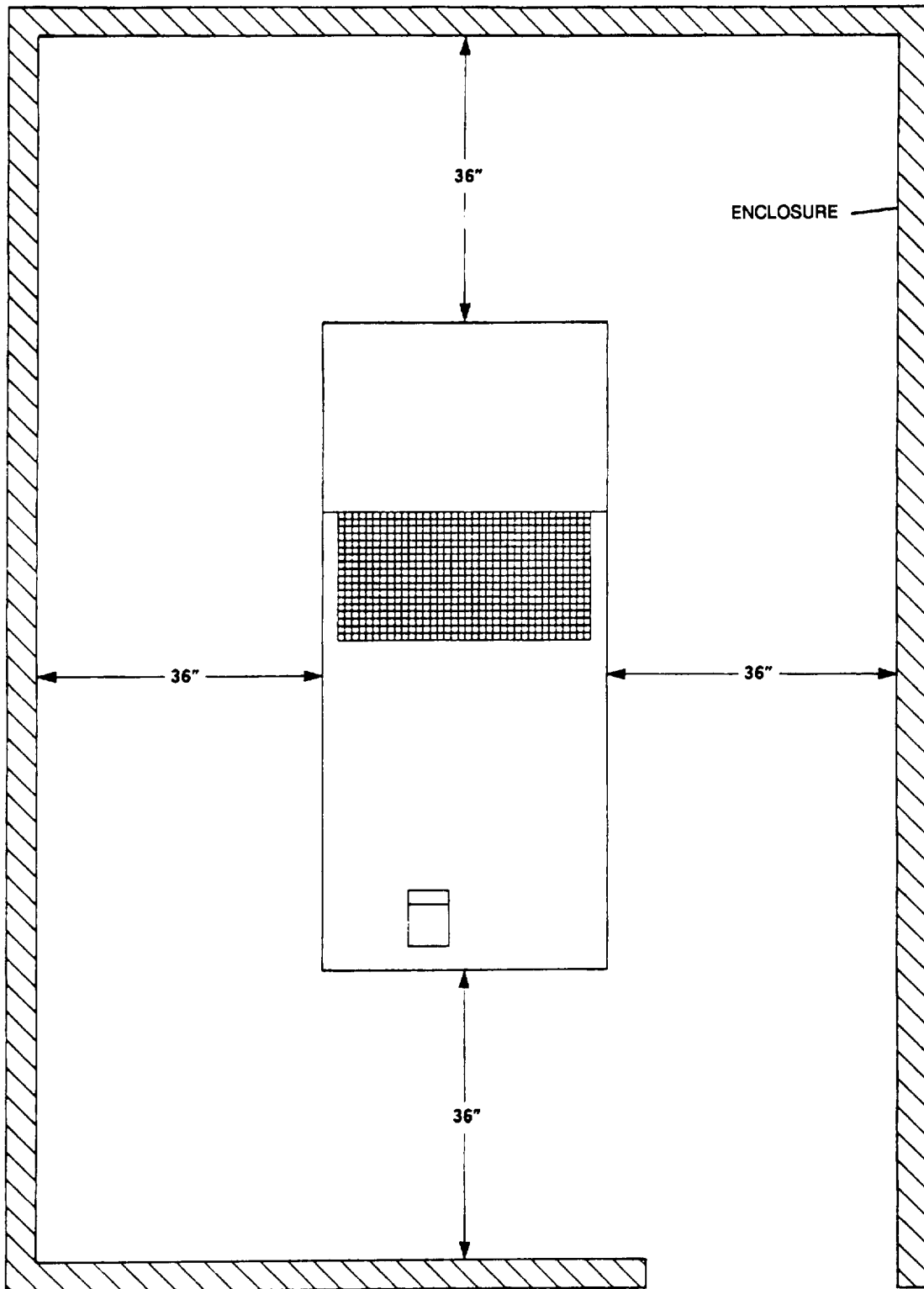

FIGURE 2-2. Minimum Enclosure Clearance Measurements

- f. Shield exhaust pipe with fireproof material at point where it passes through a flammable wall.

WARNING

An unwrapped exhaust pipe can cause injury if touched.

- g. Wrap exhaust pipe in protective material.
- h. Allow space on all sides for service and maintenance. Refer to FIGURE 2-2 for minimum clearance measurements.

2-3 FABRICATION/ASSEMBLY OF PARTS.

TABLE 2-4 is a list of generator set parts that require fabrication or assembly when replacing. See Appendix D for fabrication and assembly instructions.

TABLE 2-4. Fabricated/Assembled Parts

NAME	PART NUMBER
Cable Assembly, AC Power	88-22126-6
Cable Assembly, AC Power	88-22126-3
Cable Assembly, AC Power	88-22126-1
Cable Assembly, AC Power	88-22126-2
Cable Assembly, AC Power	88-22126-5
Cable Assembly, AC Power	88-22126-4
Cable Assembly, AC Power	88-22126-7
Cable Assembly, Battery	88-22178
Cable Assembly, Battery	88-22127
Cable Assembly, Battery	88-22181
Cable Assembly, Battery	88-22179
Cable Assembly, Battery	88-22207
Holder, Control Panel	88-22120
Hose Assembly	88-20191-6
Insulation, Panel, Top	88-22582
Insulation, Baffle	88-22592
Insulation, Baffle	88-22593
Insulation, Top, Center	88-22584
Insulation, Top, Rear	88-22585
Insulation, Front Housing	88-22591
Insulation, Top, Front	88-22586
Insulation, Top, Center	88-22587
Insulation, Top, Center	88-22588

Table 2-4. Fabricated/Assembled Parts - Continued

NAME	PART NUMBER
Insulation, Top, Front	88-22583
Pump Assembly, Fuel	88-22546
Resistor Assembly	122-3066-1
Resistor Assembly	29879
Resistor Assembly, Volt	88-22631
Resistor-Diode Assembly	88-22632
Resistor-Diode Assembly	88-22106
Solenoid Assembly	88-22553
Switch Assembly, Fuel Level	88-22548
Wire, Varistor (L0)	88-20305-5
Wire, Varistor (L1)	88-20305-1
Wire, Varistor (L2)	88-20305-2
Wire, Varistor (L3)	88-20305-3

Section II. REPAIR PARTS; SPECIAL TOOLS; TEST, MEASUREMENT, AND DIAGNOSTIC EQUIPMENT (TMDE); AND SPECIAL SUPPORT EQUIPMENT

2-4 REPAIR PARTS AND SPECIAL TOOLS LISTS (RPSTL).

2-4-1 Tools and Equipment. There are no special tools or support equipment required to perform unit level of maintenance on the generator set. A list of recommended tools and support equipment required to maintain the generator set is contained in Appendix B, Section III.

2-4-2 Maintenance Repair Parts. Repair parts and equipment are listed and illustrated in the Repair Parts and Special Tools List (RPSTL) manual TM 9-6115-644-24P.

Section III. SPECIAL LUBRICATION INSTRUCTIONS

NOTE

There are no special lubrication instructions. Refer to LO 9-6115-644-12 for generator set lubrication requirements.

Section IV. PREVENTIVE MAINTENANCE CHECKS AND SERVICES (PMCS)

2-5 PMCS PROCEDURES.

2-5-1 General. To ensure that the generator set is ready for operation at all times, it must be inspected so that defects can be discovered and corrected before they result in serious damage or failure.

2-5-2 Purpose of PMCS Table. Your Preventive Maintenance Checks and Services table lists the inspections and care of your equipment required to keep it in good operating condition.

2-5-3 Purpose of Service Intervals. The interval column of your PMCS table tells you when to do a certain check or service.

2-5-4 Procedures Column. The procedures column of your PMCS table tells you how to do the required checks and services. Carefully follow these instructions.

2-5-5 The "Equipment Is Not Ready/Available, If". This column tells you when and why the generator set cannot be used.

NOTE

The terms ready/available and mission capable refer to the same status: Generator set is on hand and is able to perform its combat missions (see DA Pam 738-750).

2-5-6 Reporting and Correcting Deficiencies. If your generator set does not perform as required, refer to the Troubleshooting section for possible problems. Report any malfunctions or failures on DA Form 2404, or refer to DA Pam 738-750.

TABLE 2-5. Unit Preventive Maintenance Checks and Services

M-Monthly Q-Quarterly S-Semi-annually A-Annually B-Bi-annually H-Hours

Item No.	Interval						Item to be Inspected	Procedures Check for and have repaired or adjusted as necessary	Equipment is not Ready/Available if:
	M	Q	S	A	B	H			
1			•			300	Engine Lube Oil	NOTE: Oil filter should be changed with lube oil change. Refer to TM 9-2815-255-24. Drain engine lube oil. Add proper lube oil per LO 9-6115-644-12.	
2				•		300	Fuel Filter/Water Separator	Change fuel filter/water separator. Refer to TM 9-2815-255-24.	
3					•	1500	Cooling System	Drain coolant and flush cooling system. Add proper coolant. Refer to paragraph 2-76-2.	
4				•			Radiator Cap	Inspect radiator cap for corrosion, torn or deteriorated seal, and obvious damage.	
5				•		300	Batteries	Remove batteries. Refer to paragraph 2-12-2. Clean batteries, cable terminals, and battery posts. Test batteries for state of charge. Refer to paragraph 2-12-1.	
6				•		300	Air Cleaner Assembly	Inspect air cleaner assembly and mounting bracket for cracks, dents, and other damage. Inspect element for clogs and damage. Clean or replace as necessary. Clean housing with cleaning cloth.	
7				•		750	Air Cleaner Tubing and Breather	Remove, clean, and inspect tubing and breather. Refer to paragraph 2-75.	
8				•		300	Hardware and Sound Insulation	Inspect for loose, damaged, or missing hardware and sound insulation. Tighten loose hardware. Repair or replace damaged or missing hardware and insulation.	

TABLE 2-5. Unit Preventive Maintenance Checks and Services - Continued

M-Monthly Q-Quarterly S-Semi-Annually A-Annually B-Bi-Annually H-Hours

Item No.	Interval						Item to be Inspected	Procedures Check for and have repaired or adjusted as necessary	Equipment is not Ready/Available if:
	M	Q	S	A	B	H			
9				•		1500	Radiator and Interior of Generator Set	Clean radiator exterior surfaces. Refer to paragraph 2-82. Clean engine compartment.	
10				•		1500	Magnetic Pickup	Remove, inspect, and clean magnetic pickup. Refer to paragraph 2-110.	Magnetic pickup is damaged.
11				•			Wiring Harness	Inspect wiring harnesses for breaks and loose connections. Repair and tighten wiring harnesses as necessary.	Wiring harnesses are damaged or connections are loose.
12				•		3000	Muffler	Check muffler for leaks, restriction, and accumulation of carbon. Replace or clean as required.	Muffler leaks, is restricted, or has excessive carbon accumulation.
13				•		300	Governor Linkage	Clean and lubricate governor actuator linkage rod ends. NOTE: If the auxiliary fuel system is used as the primary fuel source, the auxiliary fuel filter must be replaced semi-annually.	
14						500	Auxiliary Fuel Filter	Check for proper operation using the auxiliary fuel system as primary source.	
15						1500	Fan Belt	Replace fan belt. Refer to paragraph 2-84-3	

Section V. TROUBLESHOOTING

2-6 UNIT TROUBLESHOOTING PROCEDURES.

2-6-1 Purpose of Troubleshooting Table. This section contains troubleshooting information for locating and correcting operating troubles which may develop in the generator set. Each malfunction for an individual component, unit, or system is followed by a list of tests or inspections which will help you to determine probable causes and corrective actions to take. You should perform the test/inspections and corrective actions in the order listed.

This table cannot list all malfunctions that can occur, nor all tests or inspections and corrective actions. If a malfunction is not listed or cannot be corrected by listed corrective actions, notify your supervisor.

NOTE

Before you use this table, be sure you have performed your PMCS.

NOTE

Before using this table, ensure that operator level troubleshooting steps have been performed.

NOTE

Refer to Diagnostic Connector Table 2-9, the Electrical Schematic FO-1 and Wiring Diagram FO-2 as troubleshooting aids.

**SYMPTOM INDEX
 GENERATOR SET**

Troubleshooting
 Procedure
 Page

COOLING SYSTEM

Engine overheating 2-21
 Engine coolant temperature too low 2-21

ELECTRICALSYSTEM

BATTERYCHARGE ammeter
 Shows no charge when batteries are low or discharged 2-23
 Shows excessive charging after polonged operation 2-24
 AC voltmeter (VOLTS AC)
 Does not indicate voltage 2-24
 indicates voltage but FREQUENCY meter (HERTZ) is off scale 2-24
 Voltage fluctuates 2-25
 FREQUENCY meter (HERTZ)
 Frequency fluctuates 2-25

ENGINE

Fails to crank 2-15
 Cranks but fails to start 2-16
 Stops suddenly 2-17
 Runs erratically or stalls frequently 2-18
 Misfiring 2-18
 Does not develop full power... 2-18
 Knocks 2-19
 Excessive fuel consumption 2-22
 Coolant in crankcase or oil in coolant 2-22
 Vibrating 2-22
 Fails to start in cold weather 2-22

EXHAUST SYSTEM

Black or grey smoke in exhaust. 2-19
 Blue or white exhaust smoke 2-19

LUBRICATION SYSTEM

High oil consumption 2-20
 Low oil pressure 2-20
 High oil pressure 2-20

TABLE 2-6. Unit Troubleshooting

MALFUNCTION	TEST OR INSPECTION	CORRECTIVE ACTION
1.	<u>ENGINE FAILS TO CRANK.</u>	<p>Step 1. Test for defective DEAD CRANK switch, paragraph 2-111-1.</p> <p style="margin-left: 20px;">a. If DEAD CRANK switch is not defective, do step 2.</p> <p style="margin-left: 20px;">b. If defective, replace DEAD CRANK switch, paragraph 2-111.</p> <p>Step 2. Check for loose or corroded battery cable terminals or battery posts.</p> <p style="margin-left: 20px;">a. If terminals are tight and posts are dean, do step 3.</p> <p style="margin-left: 20px;">b. If not dean and tight, clean and tighten battery cable terminals and posts, paragraph 2-12-4.</p> <p>Step 3. Check that batteries are installed correctly, paragraph 2-12-5.</p> <p style="margin-left: 20px;">a. If batteries are installed correctly, do step 4.</p> <p style="margin-left: 20px;">b. If not properly installed, install batteries correctly, paragraph 2-12-5.</p> <p>Step 4. Test for low or no battery charge, paragraph 2-12-1.</p> <p style="margin-left: 20px;">a. If fully charged, do step 5.</p> <p style="margin-left: 20px;">b. If not fully charged, replace batteries, paragraph 2-12.</p> <p>Step 5. Test for defective DC CONTROL POWER oircuit breaker, paragraph 2-50-2.</p> <p style="margin-left: 20px;">a. If DC CONTROL POWER circuit breaker is not defective, do step 6.</p> <p style="margin-left: 20px;">b. If defective, replace DC CONTROL POWER circuit breaker, paragraph 2-50.</p> <p>Step 6. Test for battery voltage at input of MASTER SWITCH.</p> <p style="margin-left: 20px;">a. If battery voltage is present, do step 7.</p> <p style="margin-left: 20px;">b. If battery voltage is not present do step 8.</p> <p>Step 7. Test MASTER SWITCH output voltage in START position.</p> <p style="margin-left: 20px;">a. if battery voltage is present at MASTER SWITCH output terminal, do step 11.</p> <p style="margin-left: 20px;">b. If battery voltage is not present at output terminal, test MASTER SWITCH, paragraph 2-32-3.</p> <p>Step 8. Teat for defective battery charging ammeter shunt, paragraph 2-54-2.</p> <p style="margin-left: 20px;">a. If not defective do step 9.</p> <p style="margin-left: 20px;">b. If defective, replace battery charging ammeter shunt, paragraph 2-54.</p> <p>Step 9. Test for defective reverse battery diode (CR1), paragraph 2-66-2.</p> <p style="margin-left: 20px;">a. If not defective, do step 10.</p> <p style="margin-left: 20px;">b. If defective, replace reverse battery diode, paragraph 2-66-4.</p>

TABLE 2-6. Unit Troubleshooting - Continued

MALFUNCTION	TEST OR INSPECTION	CORRECTIVE ACTION
Step 10.	Test for defective EMERGENCY STOP switch, paragraph 2-41-3.	a. If not defective, do step 11. b. If defective, replace EMERGENCY STOP switch, paragraph 2-41.
Step 11.	Test for defective start relay (K15), paragraph 2-60-2.	a. If not defective, do step 12. b. If defective, replace start relay switch, paragraph 2-60.
Step 12.	Test for defective cranking relay (K2), paragraph 2-102-2.	a. If cranking relay is not defective, do step 13. b. If defective, replace cranking relay, paragraph 2-102.
Step 13.	Test for defective crank disconnect relay (K16), paragraph 2-60-2.	a. If crank disconnect relay is not defective, do step 14. b. If defective, replace crank disconnect relay, paragraph 2-60.
Step 14.	Check starting circuit for breaks or loose connections. Refer to Electrical Schematic FO-1.	a. If starting circuit has no breaks and connections are tight, do step 15. b. If defective, repair or replace defective wires or connections.
Step 15.	Test for defective starter solenoid, refer to TM 9-2815-255-24.	a. If starter solenoid is not defective, do step 16. b. If defective, replace starter solenoid in accordance with TM 9-2815-255-24.
Step 16.	Test for defective starting motor, refer to TM 9-2815-255-24.	a. If defective, replace starting motor in accordance with TM 9-2815-255-24. b. If starting motor is not defective, notify next higher level of maintenance.
2.	<u>ENGINE CRANKS TO START</u>	
Step 1.	Test for low battery output, paragraph 2-12-1.	a. If batteries are fully charged, do step 2. b. If not fully charged, replace batteries, paragraph 2-12.
Step 2.	Check for clogged or defective fuel filter/water separator.	a. If fuel filter/water separator is not dogged or defective, do step 3. b. If dogged or defective, replace fuel filter/water separator in accordance with TM 9-2815-255-24.

TABLE 2-6. Unit Troubleshooting - Continued

MALFUNCTION	TEST OR INSPECTION	CORRECTIVE ACTION
step 3.	Check for blocked fuel line(s) and/or components starting at injector pump inlet line.	a. If fuel lines are not blocked, do step 4. b. If blocked, unblock or replace fuel line(s) and/or components, paragraph 2-86 and/or 2-87.
step 4.	Check for air in fuel lines.	a. If air in fuel lines, bleed fuel lines in accordance with TM 9-2815-255-24. b. If no air in fuel lines, do step 5.
Step 5.	Check for contaminated or incorrect grade of fuel.	a. If fuel is not contaminated and correct grade, do step 6. b. If contaminated or incorrect grade, drain engine fuel system and replace fuel filter/water separator in accordance with TM 9-2815-255-24. Drain generator set tank. Service generator set fuel tank with clean fuel of a proper grade (TABLE 2-2).
Step 6.	Check for defective fuel supply pump, refer to TM 9-2815-255-24.	a. If defective, replace fuel supply pump in accordance with TM 9-2815-255-24. b. If fuel supply pump is not defective, notify next higher level of maintenance.
3. <u>ENGINE STOPS SUDDENLY.</u>		
Step 1.	Check for tripped protective devices.	a. If no malfunction indicator lights are lit, do step 2. b. If lit, correct fault indicated.
step 2.	Check for air lock in fuel supply line.	a. If no air lock in fuel line, do step 3. b. If air in line, bleed fuel lines in accordance with TM 9-2815-255-24.
Step 3.	Check for blocked fuel line(s) and/or components starting at injector pump inlet line.	a. If fuel lines are not blocked, do step 4. b. If blocked, unblock or replace fuel line(s) and/or components, paragraph 2-86 and/or 2-87.
Step 4.	Check for defective fuel supply pump, refer to TM 9-2815-255-24.	a. If defective, replace fuel supply pump in accordance with TM 9-2815-255-24. b. If fuel supply pump is not defective, notify next higher level of maintenance.

TABLE 2-6. Unit Troubleshooting - Continued

MALFUNCTION	TEST OR INSPECTION	CORRECTIVE ACTION
4. <u>ENGINE RUNS ERRATICALLY OR STALLS FREQUENTLY</u>		
Step 1.	Check for obstruction in fuel line(s).	<ul style="list-style-type: none"> a. If fuel lines are not obstructed, do step 2. b. If obstructed, unblock or replace fuel line(s), paragraph 2-86.
Step 2.	Check for blocked exhaust pipe or muffler.	<ul style="list-style-type: none"> a. If exhaust pipe and muffler are not blocked, do step 3. b. If blocked, unblock or replace muffler, paragraph 2-71.
Step 3.	Check for contaminated or incorrect grade of fuel.	<ul style="list-style-type: none"> a. If contaminated or incorrect grade, drain engine fuel system and replace fuel filter/water separator in accordance with TM 9-2815-255-24. Drain generator set tank. Service generator set fuel tank with clean fuel of a proper grade (TABLE 2-2). b. If fuel is not contaminated or incorrect grade, notify next higher level of maintenance.
5. <u>ENGINE MISFIRING.</u>		
Step 1.	Check for contaminated or incorrect grade of fuel.	<ul style="list-style-type: none"> a. If fuel is not contaminated and is correct grade, do step 2. b. If contaminated or incorrect grade, drain engine fuel system and replace fuel filter/water separator in accordance with TM 9-2815-255-24. Drain generator set tank. Service generator set tank with dean fuel of a proper grade (TABLE 2-2).
Step 2.	Check for air in fuel lines.	<ul style="list-style-type: none"> a. If air in lines, bleed fuel lines in accordance with TM 9-2815-255-24. b. If no air in fuel lines, and trouble persists, notify next higher level of maintenance.
6. <u>ENGINE DOES NOT DEVELOP FULL POWER.</u>		
Step 1.	Check for restricted fuel filter/water separator.	<ul style="list-style-type: none"> a. If fuel fitter/water separator is not restricted, do step 2. b. If restricted, replace fuel filter/water separator in accordance with TM 9-2815-255-24.
step 2.	Check for contaminated or incorrect grade of fuel.	<ul style="list-style-type: none"> a. If fuel is not contaminated and is correct grade, do step 3. b. If contaminated or incorrect grade, drain engine fuel system and replace fuel filter/water separator in accordance with TM 9-2815-255-24. Drain generator set tank. Service generator set tank with dean fuel of proper grade (TABLE 2-2).

TABLE 2-6. Unit Troubleshooting - Continued

MALFUNCTION	TEST OR INSPECTION	CORRECTIVE ACTION
	Step 3. Check for blocked air intake system. <ul style="list-style-type: none"> a. If air intake system is not blocked, do step 4. b. If blocked, unblock or replace air intake system components as required, paragraph 2-72, 2-73. Step 4. Check blocked exhaust pipe or muffler. <ul style="list-style-type: none"> a. If blocked, unblock or replace muffler, paragraph 2-71. b. If exhaust pipe and muffler are not blocked, and trouble persists, notify next higher level of maintenance. 	
7.	<u>ENGINE KNOCKS.</u>	Check for contaminated or incorrect grade of fuel. <ul style="list-style-type: none"> a. If contaminated or incorrect grade, drain engine fuel system and replace fuel filter/water separator in accordance with TM 9-2815-255-24. Drain generator set tank. Service generator set fuel tank with clean fuel of a proper grade (TABLE 2-2). b. If fuel is not contaminated and is correct grade, and trouble persists, notify next higher level of maintenance.
8.	<u>BLACK OR GREY SMOKE IN EXHAUST.</u>	Check for improper grade of fuel. <ul style="list-style-type: none"> a. If improper grade of fuel, drain engine fuel system. Drain generator set tank. Service generator set fuel tank with clean fuel of a proper grade (TABLE 2-2). b. If proper grade of fuel, and trouble persists, notify next higher level of maintenance.
	<u>BLUE OR WHITE EXHAUST SMOKE.</u>	Step 1. Check for excessive engine oil level. <ul style="list-style-type: none"> a. If oil level is proper, do step 2. b. If oil level is excessive, drain to proper level, paragraph 2-1-2-4. Step 2. Check for improper grade of fuel. <ul style="list-style-type: none"> a. If proper grade of fuel, do step 3. b. If improper grade, drain engine fuel system and generator set tank. Service generator set fuel tank with clean fuel of a proper grade (TABLE 2-2). Step 3. Check for defective thermostat, refer to TM 9-2815-255-24. <ul style="list-style-type: none"> a. If defective, replace thermostat in accordance with TM 9-2815-255-24. b. If thermostat is not defective, and trouble persists, notify next higher level of maintenance.

TABLE 2-6. Unit Troubleshooting - Continued

MALFUNCTION	TEST OR INSPECTION	CORRECTIVE ACTION
10. <u>HIGH OIL CONSUMPTION.</u>	Step 1.	Check for blocked air intake system. <ol style="list-style-type: none"> a. If air intake system is not blocked, do step 2. b. If blocked, unblock or replace air intake system components as required, paragraph 2-72, 2-73.
	Step 2.	Check for improper lube oil type. <ol style="list-style-type: none"> a. If improper, drain oil and refill with proper lube oil type (TABLE 2-3), paragraph 2-113-2. Replace oil filter in accordance with TM 9-2815-255-24. b. If proper lube oil type, and trouble persists, notify next higher level of maintenance.
11. <u>LOW OIL PRESSURE.</u>	Step 1.	Check for improper lube oil type. <ol style="list-style-type: none"> a. If proper lube oil type, do step 2. b. If improper, drain oil and refill with proper lube oil in accordance with LO 9-6115-644-12. Replace oil filter in accordance with TM 9-2815-255-24.
	Step 2.	Test for defective OIL PRESSURE indicator, paragraph 2-25-2. <ol style="list-style-type: none"> a. If OIL PRESSURE indicator is not defective, do step 3. b. If defective, replace OIL PRESSURE indicator, paragraph 2-25
	Step 3.	Test for defective oil pressure sender, paragraph 2-107-1. <ol style="list-style-type: none"> a. If defective, replace oil pressure sender, paragraph 2-107. b. If oil pressure sender is not defective, and trouble persists, notify next higher level of maintenance.
12. <u>HIGH OIL PRESSURE.</u>	Step 1.	Check for improper lube oil type. <ol style="list-style-type: none"> a. If proper lube oil type, do step 2. b. If improper, drain oil and refill with proper lube oil type in accordance with LO9-6115-644-12.
	Step 2.	Test for defective OIL PRESSURE indicator, paragraph 2-25-2. <ol style="list-style-type: none"> a. If OIL PRESSURE indicator is not defective, do step 3. b. If defective, replace OIL PRESSURE indicator, paragraph 2-25.

TABLE 2-6. Unit Troubleshooting - Continued

/MALFUNCTION	TEST OR INSPECTION	CORRECTIVE ACTION
	Step 3.	Test for defective oil pressure sender, paragraph 2-107-1. a. If defective, replace oil pressure sender, paragraph 2-107. b. If oil pressure sender is not defective, and trouble persists, notify next higher level of maintenance.
13. <u>ENGINE OVERHEATING.</u>		
	Step 1.	Check for broken or loose fan belt, paragraph 2-84. a. If fan belt is not broken and tension is correct, do step 2. b. If worn or broken, replace fan belt. If loose, adjust fan belt, paragraph 2-84-2.
	Step 2.	Check for defective radiator cap, paragraph 2-77-2. a. If radiator cap is not defective, do step 3. b. If defective, replace radiator cap, paragraph 2-77.
	Step 3.	Check for defective coolant hose(s). a. If coolant hoses are not leaking or collapsed, do step 4. b. If defective, replace coolant hose(s), paragraphs 2-77, and 2-79 through 2-81.
	Step 4.	Test for defective thermostat, refer to TM 9-2815-255-24. a. If thermostat is not defective, do step 5. b. If defective, replace thermostat in accordance with TM 9-2815-255-24.
	Step 5.	Check for dogged radiator. a. If radiator is not clogged, do step 6. b. If dogged, remove obstruction or replace radiator, paragraph 2-82.
	Step 6.	Check for defective water pump, refer to TM 9-2815-255-24. a. If defective, replace water pump in accordance with TM 9-2815-255-24. b. If water pump is not defective, and trouble persists, notify next higher level of maintenance.
14. <u>ENGINE COOLANT TEMPERATURE TOO LOW.</u>		
	Step 1.	Check for defective thermostat, refer to TM 9-2815-255-24. a. If thermostat is operating correctly, do step 2. b. If defective, replace thermostat in accordance with TM 9-2815-255-24.
	Step 2.	Test for defective temperature sender, paragraph 2-108-1. a. If temperature sender is not defective, do step 3. b. If defective, replace temperature sender, paragraph 2-108.

TABLE 2-6. Unit Troubleshooting - Continued

MALFUNCTION	TEST OR INSPECTION	CORRECTIVE ACTION
Step 3.	Test for defective COOLANT TEMP. indicator, paragraph 2-24-2.	a. If defective, replace COOLANT TEMP. indicator, paragraph 2-24. b. If COOLANT TEMP. indicator is not defective, and trouble persists, notify next higher level of maintenance.
15. <u>EXCESSIVE FUEL COMPTION.</u>	Step 1. Check for blocked air intake system.	a. If air intake system is not blocked, do step 2. b. If blocked, unblock or replace air intake system components as required, paragraph 2-72 and 2-73.
Step 2.	Check for leaks in fuel system.	a. If no leaks in fuel system, do step 3. b. If leaks found, repair fuel system as required.
Step 3.	Check for contaminated oil.	a. If oil is contaminated, change oil, paragraph 2-113-2. b. If oil is not contaminated or trouble persists, notify next higher level of maintenance.
16. <u>COOLANT IN CRANKCASE OR OIL IN COOLANT.</u>	Check for defective oil cooler.	a. If defective, replace oil cooler, refer to TM 9-2815-255-24. b. If oil cooler is not defective, and trouble persists, notify next higher level of maintenance.
17. <u>ENGINE VIBRATING.</u>	Step 1. Check for bent or broken cooling fan blades.	a. If fan blades are not damaged, do step 2. b. If damaged, replace cooling fan, paragraph 2-83.
Step 2.	Check for loose or defective engine mounts.	a. Tighten loose mounting bolts. b. If bolts are tight and problem persists, notify next higher level of maintenance.
18. <u>ENGINE FAILS TO START IN COLD WEATHER.</u>	Step 1. Test for low or no battery charge, paragraph 2-12-1.	a. If batteries are fully charged, do step 2. b. If not fully charged, replace batteries, paragraph 2-12.

TABLE 2-6. Unit Troubleshooting - Continued

MALFUNCTION	TEST OR INSPECTION	CORRECTIVE ACTION
Step 2.	Check for improper lube oil type.	a. If proper lube oil type, do step 3. b. If improper, drain oil and refill with proper lube oil type (TABLE 2-3), paragraph 2-113-2. Replace oil filter in accordance with TM 9-2815-255-24.
Step 3.	Check for improper grade of fuel.	a. If proper grade of fuel, do step 4. b. If improper, drain engine fuel system. Drain generator set tank. Service generator set fuel tank with dean fuel of a proper grade (TABLE 2-2).
Step 4.	Check for defective ether start system, paragraphs 2-94 and 2-95.	a. If ether start system is operating properly, do step 5. b. Replace defective parts, paragraphs 2-94 and 2-95.
Step 5.	Test for defective ETHER SWITCH, paragraph 2-33-3.	a. If defective, replace ETHER SWITCH, paragraph 2-33. b. If ETHER SWITCH is not defective, and trouble persists, notify next higher level of maintenance.
19. <u>BATTERY CHARGE AMMETER SHOWS NO CHARGE WHEN BATTERIES ARE LOW OR DISCHARGED.</u>		
Step 1.	Check for broken or loose fan belt, paragraph 2-84.	a. If fan belt is not broken and tension is correct, do step 2. b. If worn or broken, replace fan belt. If loose, adjust fan belt, paragraph 2-84-2.
Step 2.	Check for defective BATTERY CHARGER FUSE, paragraph 2-49-2.	a. If BATTERY CHARGER FUSE is not blown, do step 3. b. If defective, replace BATTERY CHARGER FUSE, paragraph 2-49.
Step 3.	Test for defective battery charging ammeter shunt, paragraph 2-54-2.	a. If shunt is not defective, do step 4. b. If defective, replace battery charging ammeter shunt, paragraph 2-54-4.
Step 4.	Test for defective alternator, refer to TM9-2815-255-24.	a. If alternator is not defective, do step 5. b. If defective, replace alternator in accordance with TM 9-2815-255-24.
step 5.	Test for defective BATTERY CHARGE ammeter, paragraph 2-27-2.	a. If BATTERY CHARGE is not defective, do step 6. b. If defective, replace BATTERY CHARGE ammeter, paragraph 2-27.

TABLE 2-6. Unit Troubleshooting - Continued

MALFUNCTION	TEST OR INSPECTION	CORRECTIVE ACTION
Step 6.	Check for breaks or loose connections in charging circuit.	If breaks or loose connections are found, repair charging circuit, refer to Electrical Schematic FO-1.
<u>20. BATTERY CHARGE AMMETER SHOWS EXCESSIVE CHARGING AFTER PROLONGED OPERATION.</u>		
Step 1.	Test for defective batteries, paragraph 2-12-1.	a. If batteries are not defective, do step 2. b. If defective, replace batteries, paragraph 2-12.
Step 2.	Test for defective BATTERY CHARGE ammeter, paragraph 2-27-2.	a. If BATTERY CHARGE ammeter is not defective, do step 3. b. If defective, replace BATTERY CHARGE ammeter, paragraph 2-27.
Step 3.	Test for defective alternator, refer to TM 9-2815-255-24.	a. If alternator is not defective, do step 4. b. If defective, replace alternator in accordance with TM 9-2815-255-24.
Step 4.	Check for short in charging circuit.	If shorted, repair charging circuit, refer to Electrical Schematic FO-1.
<u>21. AC VOLTMETER (VOLTS AC) INDICATE CORRECT VOLTAGE.</u>		
Step 1.	Test for defective AC Voltmeter (VOLTS AC), paragraph 2-31-2.	a. If AC Voltmeter (VOLTS AC) is not defective, do step 2. b. If defective, replace AC Voltmeter (VOLTS AC), paragraph 2-31.
Step 2.	Test for defective VOLTAGE adjust potentiometer, paragraph 2-34-3.	a. If VOLTAGE adjust potentiometer is not defective, do step 3. b. If defective, replace VOLTAGE adjust potentiometer, paragraph 2-34.
Step 3.	Test for defective AM-VM transfer switch, paragraph 2-39-3.	a. If defective, replace AM-VM transfer switch, paragraph 2-39. b. If AM-VM transfer switch is not defective, and trouble persists, notify next higher level of maintenance.
<u>22. AC VOLTMETER (VOLTS AC) INDICATES VOLTAGE. BUT FREQUENCY METER (HERTZ) IS OFF SCALE.</u>		
Step 1.	Test for defective frequency transducer, paragraph 2-52-2.	a. If frequency transducer is not defective, do step 2. b. If defective, replace frequency transducer, paragraph 2-52.

TABLE 2-6. Unit Troubleshooting - Continued

MALFUNCTION	TEST OR INSPECTION	CORRECTIVE ACTION
	Step 2.	Test for defective FREQUENCY meter (HERTZ), paragraph 2-28-2. a. If defective, replace FREQUENCY meter (HERTZ), paragraph 2-28. b. If FREQUENCY meter (HERTZ) is not defective, and trouble persists, notify next higher level of maintenance.
23.	<u>AC VOLTMETER (VOLTS AC) VOLTAGE FLUCTUATES.</u>	Step 1. Check for loose electrical connections, refer to Electrical Schematic FO-1. a. If no loose connections, do step 2. b. If loose tighten electrical connections. Step 2. Test for defective AC Voltmeter (VOLTS AC), paragraph 2-31-2. a. If AC Voltmeter (VOLTS AC) is not defective, do step 3. b. If defective, replace AC Voltmeter (VOLTS AC), paragraph 2-31. Step 3. Test for defective VOLTAGE adjust potentiometer, paragraph 2-34-3. a. If VOLTAGE adjust potentiometer is not defective, do step 4. b. If defective, replace voltage adjust potentiometer, paragraph 2-34. Step 4. Test for defective AM-VM transfer switch, paragraph 2-39-3. a. If AM-VM transfer switch is not defective, do step 5. b. If defective, replace AM-VM transfer switch, paragraph 2-39. Step 5. Check for defective load measuring unit, paragraph 2-65 a. If defective, replace load measuring unit, paragraph 2-65-2. b. If load measuring unit is not defective, and trouble persists, notify next higher level of maintenance.
24.	<u>FREQUENCY METER (HERTZ) FREQUENCY FLUCTUATES.</u>	Step 1. Check for erratic engine operation. Refer to Malfunction 4 "Engine Runs Erratically or Stalls Frequently." If engine operating property, do step 2. Step 2. Test for defective frequency transducer, paragraph 2-52-2. a. If frequency transducer is not defective, do step 3. b. If defective, replace frequency transducer, paragraph 2-52. Step 3. Test for defective FREQUENCY meter (HERTZ), paragraph 2-28-2. a. If defective, replace FREQUENCY meter (HERTZ), paragraph 2-28. b. If FREQUENCY meter (HERTZ) is not defective, and trouble persists, notify next higher level of maintenance.

TABLE 2-6. Unit Troubleshooting - Continued.

MALFUNCTION	TEST OR INSPECTION	CORRECTIVE ACTION
<u>25. NO VOLTAGE AT CONVENIENCE RECEPTACLE.</u>		
Step 1.	Open control panel and inspect circuit interrupter on side of Ground Fault Circuit Interrupter device.	<ul style="list-style-type: none"> a. If device is tripped reset device for generator sets, contract number DAAK01-94-D-0036. b. For generator sets, contract number DAAK01-88-D-D082, check in-line fuse on black lead of Ground Fault Circuit Interrupter. c. If device is not tripped, do Step 2.
Step 2.	Check Ground Fault Circuit Interrupter.	<ul style="list-style-type: none"> a. If indicator is tripped, reset by pressing RESET button. b. If indicator is not tripped, do Step 3.
Step 3.	Check voltage across convenience receptacle.	<ul style="list-style-type: none"> a. If voltage is present, replace convenience receptacle. b. If voltage is not present, do Step 4.
Step 4.	Check voltage across Terminals 4 and 6 no TB-5.	<ul style="list-style-type: none"> a. If voltage is present, replace Ground Fault Circuit Interrupter. b. If voltage is not present, search for loose or broken wires or loose pin in connectors.

Section VI. RADIO INTERFERENCE SUPPRESSION

2-7 GENERAL METHODS USED TO ATTAIN PROPER SUPPRESSION

Suppression is attained by providing a low resistance path to ground for stray currents. The methods used include shielding the ignition and high frequency wires, grounding the frame with bonding straps, and using filtering systems

2-8 INTERFERENCE SUPPRESSION COMPONENTS

2-8-1 Primary Suppression Components Primary suppression components are those whose primary function is to suppress electromagnetic interference.

The primary suppression components on this generator set are the output box access door EMI seal (outer seal), paragraph 2-18, the load output terminal board EMI filters, paragraph 2-103, and the voltage reconnection terminal board capacitors, paragraph 4-9.

2-8-2 Secondary Suppression Components Secondary suppression components have electromagnetic interference suppression functions which are incidental or secondary to their primary function. The only secondary suppression component for the generator set is the housing, refer to Section IX, Maintenance of Housing for removal and installation procedures.

Section VII. SPECIAL INSTRUCTIONS

2-9 NUCLEAR BIOLOGICAL CHEMICAL CONTAMINATION The generator set is capable of being operated by personnel wearing nuclear, biological, or chemical (NBC) protective clothing without special tools or support equipment Refer to FM 3-5, NBC Decontamination for Information on decontamination procedures. Specific procedures for the generator set are the following:

2-9-1 Control panel indicators sealing gaskets rubber sleeves, rope draw cords at output terminal access ports, control panel door gaskets, access door gaskets, rubber tubing and belts within the engine compartment, coverings for electrical conduits, external water drain tubing, and retaining cords for slave receptacle covers will absorb and retain chemical agents Replacement of these items is the recommended method of decontamination.

2-9-2 Lubricants, fuel, coolant, or battery fluid may be present on the external surfaces of the generator set or components due to leaks or normal operation These fluids will absorb NBC agents. The preferred method of decontamination is removal of these fluids using conventional decontamination methods in accordance with FM 3-5.

2-9-3 Continued decontamination of external generator set surfaces with super-tropical bleach (STB)/ decontaminating solution number 2 (DS2) will degrade clear plastic indicator coverings to a point where reading indicators will become impossible This problem will become more evident for soldiers wearing protective masks. Therefore, the use of STB or DS2 decontaminants in these areas should be minimized. Indicators should be decontaminated with warm soapy water.

2-9-4 External surfaces of the control panel assembly that are marked with painted or stamped lettering will not withstand repeated decontamination with STB or DS2 without degradation of this lettering. The recommended method of decontamination for these areas is warm soapy water.

2-9-5 Areas that will entrap contaminants, making efficient decontamination extremely difficult, include the following: space behind knobs and switches on the control panel, exposed heads of screws, areas adjacent to and behind exposed wiring conduits, hinged areas of access doors, spaces behind externally mounted equipment specification data plates, areas around external oil drain valve, retaining chains for external receptacle covers, areas behind external receptacle covers, access door locking mechanisms, recessed wells for access door handles, fuel caps, load output terminal board access door, slave receptacles, frequency adjustment controls, areas around tie-down/lifting rings, crevices around access doors, external screens covering ventilation areas, and areas adjacent to the external fuel drain valve. Replacement of these items, if available, is the preferred method of decontamination. Conventional decontamination methods should be used on these areas, while stressing the importance of thoroughness and the probability of some degree of continuing contact and vapor hazard.

2-9-6 In an NBC contaminated environment, the generator set should be operated with all access doors closed to reduce the effects of contamination.

2-9-7 The use of overhead shelters or chemical protective covers is recommended as an additional means of protection against contamination in accordance with FM 3-5. When using covers, care should be taken to provide adequate space for air flow and exhaust.

2-9-8 For additional NBC information refer to FM 3-3 and 3-4. Other services use applicable publications for NBC.

Section VIII. MAINTENANCE OF DC ELECTRICAL SYSTEM

2-10 INTRODUCTION.

This section contains unit maintenance procedures for the DC Electrical System. Deficiencies noted during inspection/repair which are beyond the scope of unit maintenance shall be reported to the next higher level of maintenance.

NOTE

Refer to TM 9-6115-644-10 for all operator procedures

2-11 BATTERY AND SLAVE RECEPTACLE CABLES.

WARNING

Batteries give off a flammable gas. Do not smoke or use open flame when performing maintenance. Flames and explosion could result in severe personal injury or death.

WARNING

Remove metal jewelry when working on electrical system or components. Failure to observe this warning could result in severe personal injury or death by electrocution.

NOTE

This procedure is typical for the positive, negative, and interconnect battery cables, and the positive and negative NATO slave receptacle cables.

2-11-1 Inspection.

- a. Shut down generator set.
- b. Open battery access door and right side engine access doors.
- c. Inspect battery/slave receptacle cables for security; cracked insulation; broken, burned or corroded terminals; missing parts; or other damage.
- d. Close access doors.

2-11-2 Removal.

- a. Shut down generator set.
- b. Open battery access door and right side engine access doors.

NOTE

Tag all cables before removal.

- c. Disconnect negative battery cable terminal lug (1, FIGURE 2-3) from battery.
- d. Disconnect and remove applicable cable assembly as shown in FIGURE 2-3 or FIGURE 2-4.

2-11-3 Cleaning.

- a. Remove terminal cover(s) (2, FIGURE 2-3) from battery post(s), if applicable.
- b. Clean battery post(s) and cable terminals with battery terminal cleaner.
- c. Install terminal cover(s) (2), if removed.

2-11-4 Repair

NOTE

If cable cannot be repaired, refer to Appendix D.

- a. Remove nut(s) (5, FIGURE 2-3) and battery cable terminal lug(s), as necessary.
- b. Remove broken or damaged terminal (3, FIGURE 2-3 or 2-4) from cable assembly.
- c. Slide new shrinkable tubing (4, FIGURE 2-3 or 2-4) over cable end.
- d. Install terminal (3) to cable end as described in Appendix D.
- e. Heat shrinkable tubing (4) with heat gun until secure.
- f. Install battery cable terminal lug(s) with nut(s) (5, FIGURE 2-3), as necessary.

2-11-5 Installation.

- a. Install applicable cable assembly as shown in FIGURE 2-3 or 2-4.
- b. Connect negative battery cable terminal lug (1, FIGURE 2-3) to battery.
- c. Close access doors.

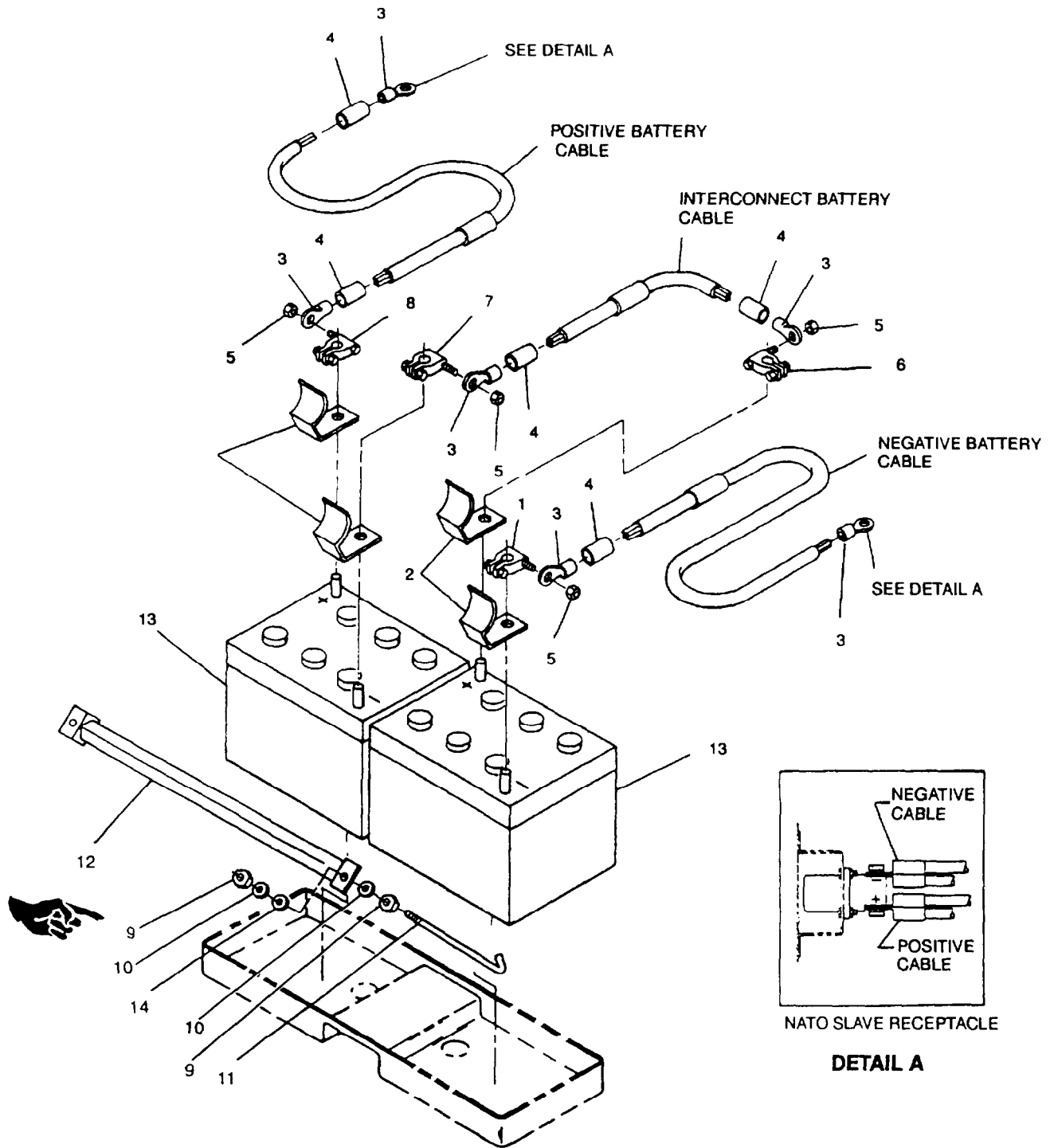

FIGURE 2-3. Batteries and Cables

2-12 BATTERIES.

2-12-1 Testing.

WARNING

Batteries give off a flammable gas. Do not smoke or use open flame when performing maintenance. Flames and explosion could result in severe personal injury or death.

- a. Shut down generator set.
- b. Open battery access door and disconnect negative battery cable.
- c. Remove battery vent caps.
- d. Test specific gravity of electrolyte in each battery cell with a hydrometer. Refer to TABLE 2-7 for state of charge with specific gravity corrected to 80° F (27°C). Refer to TABLE 2-8 for specific gravity temperature corrections.
- e. Recharge or replace batteries as necessary. Retest batteries per above instructions
- f. Install battery vent caps.
- g. Connect negative battery cable. Close battery access door.

2-12-2 Removal.

- a. Shut down generator set.

TABLE 2-7. State of Charge with Specific Gravity Corrected to 80°F (27°C)

Specific Gravity	Percent Charge
1.280	100
1.250	75
1.220	50
1.190	25
1.160	Little useful capacity.
1.130	Discharged

TABLE 2-8. Specific Gravity Temperature Corrections

Temperature "F	Correction Factor
+120°F (49°C)	+0.016
+115°F (46°C)	+0.014
+110°F (43°C)	+0.012
+105°F (41°C)	+0.010
+100°F (38°C)	+0.008
+95°F (35°C)	+0.006
+90°F (32°C)	+0.004
+85°F (29°C)	+0.002
+80°F (27°C)	0
+75°F (24°C)	-0.002
+70°F (21°C)	-0.004
+65°F (19°C)	-0.006
+60°F (16°C)	-0.008
+55°F (13°C)	-0.010
+50°F (10°C)	-0.012
+45°F (7°C)	-0.014
+40°F (5°C)	-0.016
+35°F (2°C)	-0.018
+30°F (-1°C)	-0.020
+25°F (-4°C)	-0.022
+20°F (-7°C)	-0.024
+15°F (-9°C)	-0.026
+10°F (-12°C)	-0.028
+5°F (-15°C)	-0.030
0°F (-18°C)	-0.032
-5°F (-20°C)	-0.034
-10°F (-23°C)	-0.036
-15°F (-26°C)	-0.038
-20°F (-29°C)	-0.040

- b. Open battery compartment access door.
- c. Disconnect negative battery cable terminal lug (1, FIGURE 2-3).
- d. Disconnect interconnect battery cable terminal lugs (6) and (7) and remove interconnect battery cable assembly.
- e. Disconnect positive battery cable terminal lug (8).

WARNING

Ensure proper lifting techniques are used when lifting batteries. Failure to observe this warning could result in personal injury.

- f. Remove nuts (9), washers (10), lockwashers (14), clamps (11), and retaining bar (12).
- g. Remove batteries (13).

2-12-3 **Inspection.**

- a. Remove batteries, paragraph 2-12-2.
- b. Inspect batteries for cracked cases; broken, burned or corroded posts; missing parts; and other damage.
- c. Install batteries, paragraph 2-12-5.

2-12-4 **Service.**

- a. Remove terminal covers (2, FIGURE 2-3).
- b. Clean cable terminal lugs and battery posts.
- c. Install terminal covers (2) on batteries (13).

2-12-5 **Installation.**

- a. Position batteries (13, FIGURE 2-3) in generator set. Ensure that batteries are serviced and fully charged.
- b. Apply general purpose grease (Item 10, Appendix C) to battery posts and cable terminal lugs (1), (6), (7), and (8). (F) Apply petrolatum or equal.
- c. Install clamps (11) and retaining bar (12) with lockwashers (14), washers (10), and nuts (9).

WARNING

Connect negative battery cable terminal lug (1) last when installing battery cables. Failure to follow this procedure could result in sparks which can ignite volatile battery gases.

- d. Connect positive cable terminal lug (8).
- e. Position interconnect battery cable and connect terminal lugs (6) and (7).
- f. Connect negative battery cable terminal lug (1) and close battery compartment access door.

2-13 **NATO SLAVE RECEPTACLE.**

2-13-1 **Inspection.**

- a. Shut down generator set.
- b. Open battery access door.
- c. Inspect NATO slave receptacle for loose connections, corrosion, missing hardware, and other damage.
- d. Close battery access door.

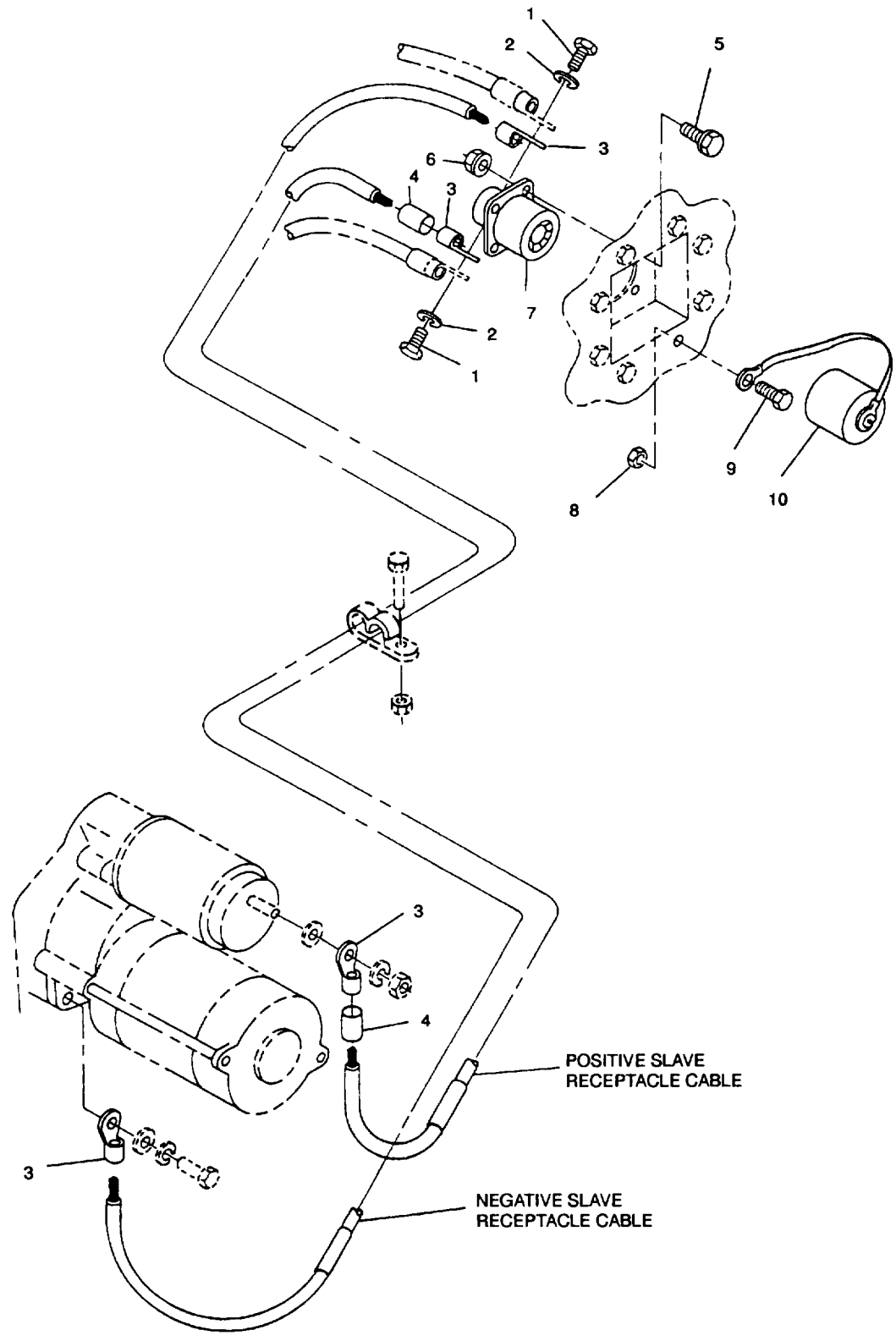

FIGURE 2-4. NATO Slave Receptacle and Cables

2-13-2 Removal.

- a. Shut down generator set.
- b. Open battery access door and disconnect negative battery cable.
- c. Tag and disconnect battery and stave receptacle cables from slave receptacle (7, FIGURE 2-4) by removing bolts (1) and lockwashers (2).
- d. Remove bolts (5), nuts (6), and NATO slave receptacle (7) from generator set housing.
- e. Remove nut (8), bolt (9), and cover (10) from generator set.

2-13-3 Installation.

- a. Insert NATO slave receptacle (7, FIGURE 2-4) into generator set housing.
- b. Secure receptacle (7) with bolts (5) and nuts (6).
- c. Connect slave receptacle and battery cables to slave receptacle (7) with bolts (1) and lockwashers (2). Remove tags.
- d. Install cover (10) on generator set with bolt (9) and nut (8).
- e. Connect negative battery cable. Close battery access door.

Section IX. MAINTENANCE OF HOUSING

2-14 ACCESS DOORS.

NOTE

This procedure is written for the left rear engine access door, but is typical for all access doors, hinges, latches, storage boxes, and data plates.

NOTE

When removing and installing battery access door, note position of spacers for door hold open mechanism.

2-14-1 Removal

- a. Shut down generator set.
- b. Open left side engine access doors.
- c. Remove nuts (1, FIGURE 2-5), lockwashers (2), bolts (3), washers (4), and hinges (5).
- d. Remove left rear engine access door (6) from generator set.
- e. Remove assembly nuts (7), bolts (8), and document box (9) from engine access door (6).
- f. Drill out rivets (10) and remove fuel system diagram (11) from document box (9).
- g. Remove assembled nuts (12), hits (13), bracket (14), and holding rod (15) from engine access door (6).
- h. Remove assembled nuts (16), bolts (17), and bracket (18) from engine access door (6).
- i. Remove nuts (19), screws (20), and latches (21) from engine access door (6).

2-14-2 Inspection.

- a. Shut down generator set.
- b. Inspect access doors, hinges, latches, and baffles for loose and missing hardware, cracks, dents, loose paint, and corrosion.
- c. Inspect data plates for readability, and loose or missing rivets.

2-14-3 Repair.

WARNING

Wear a protective mask and gloves when sanding CARC painted surfaces. CARC paint dust is a health hazard and could cause personal injury if warning is not followed.

- a. Repair all dents and cracks, and remove loose paint.
- b. Remove light corrosion with fine grit abrasive paper (Item 16, Appendix C).
- c. Repaint surfaces in accordance with TM 43-0139. (F) Use applicable directives.
- d. Replace unreadable data plates.
- e. Replace loose or missing rivets.

2-14-4 Installation.

- a. Install latches (21, FIGURE 2-5) in left rear engine access door (6) with screws (20) and nuts (19).
- b. Install bracket (18) on engine access door (6) with bolts (17) and assembled nuts (16).
- c. Install bracket (14) and holding rod (15) on engine access door (6) with bolts (13) and assembled nuts (12).
- d. Install fuel system diagram (11) on document box (9) with rivets (10).
- e. Install document box (9) on engine access door (6) with bolts (8) and assembled nuts (7).
- f. Install left rear engine access door (6) and hinges (5) on generator set with bolts (3), washers (4), lockwashers (2), and nuts (1).
- g. Close left side engine access doors.

2-15 CONTROL BOX TOP PANEL.

2-15-1 Removal.

- a. Shutdown generator set.
- b. Open battery access door and disconnect negative battery cable.

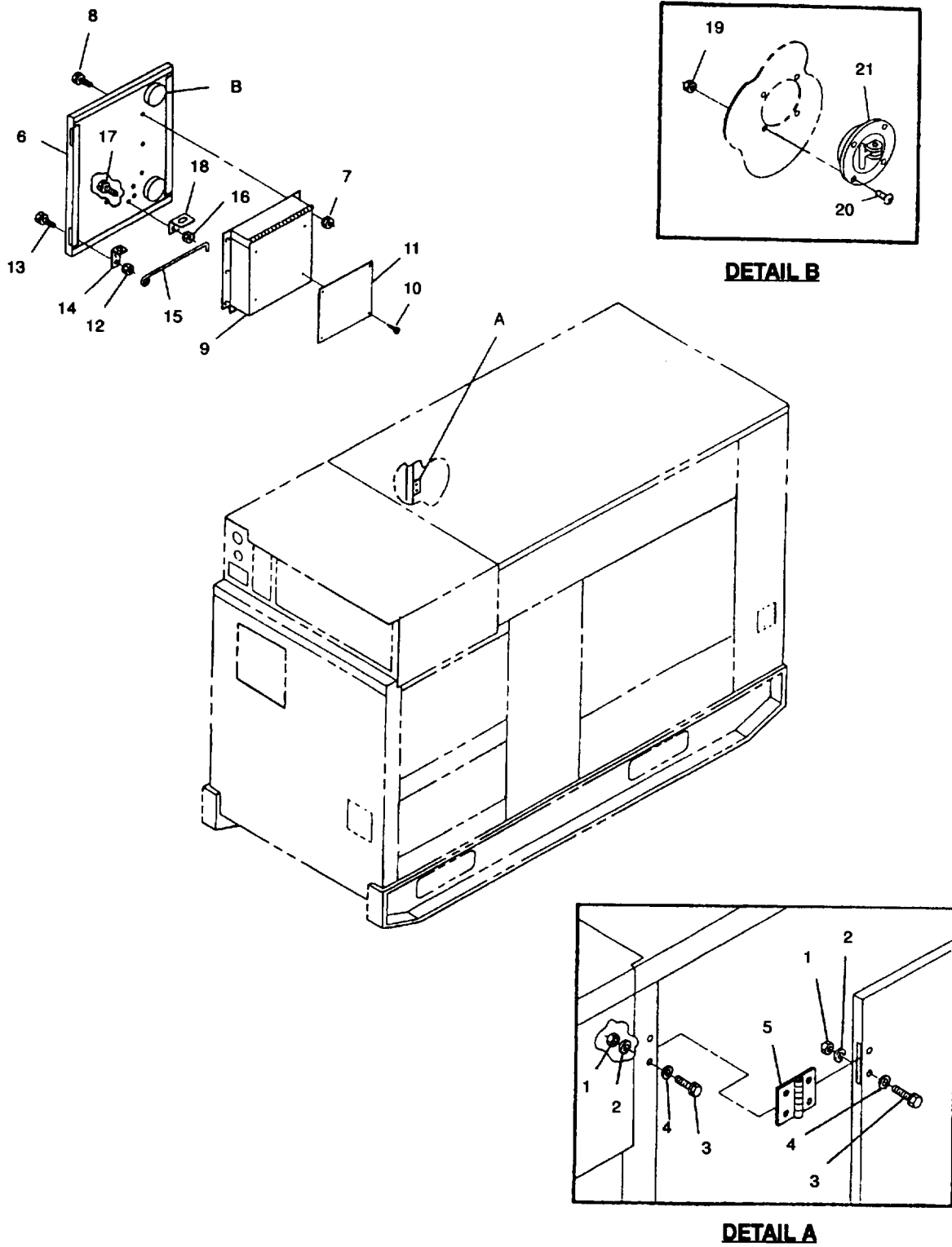

FIGURE 2-5. Generator Set Access Doors

- c. Remove control panel access door, paragraph 2-14-1.
- d. Lower control panel and remove bolts (1, FIGURE 2-6), flatwashers (2), lockwashers (3), and assembled nuts (4) from top panel (5).

CAUTION

The control box top panel is attached to the generator set with a silicone sealant to prevent water from entering the control box. Care must be taken not to bend or scratch the control box top panel when separating.

- e. Separate and remove control box top panel (5) by prying to break loose sealant.
- f. If damaged, removed gasket (15).
- g. Remove bolts (6), washers (7), lockwashers (8), nuts (9), and stiffener (10) from control box assembly.
- h. Remove bolts (11), assembled nuts (12), bracket (13), and ring (14), from control box top panel (5).

2-15-2 Inspection.

- a. Shut down generator set.
- b. Open battery access door and disconnect negative battery cable.
- c. Inspect control box top panel (5, FIGURE 2-6) for dents, cracks, loose paint, and corrosion.

2-15-3 Repair.

WARNING

Wear a protective mask and gloves when sanding CARC painted surfaces. CARC paint dust is a health hazard and could cause personal injury if warning is not followed.

- a. Repair all dents and cracks, and remove all loose paint.
- b. Remove light corrosion with fine grit abrasive paper (Item 16, Appendix C).
- c. Repaint surfaces in accordance with TM 43-0139. (F) Refer to applicable directives

2-1 5-4 Installation.

- a. Install ring (14, FIGURE 2-6) and bracket (13) on control box top panel (5) with bolts (11) and assembled nuts (12).
- b. Install stiffener (10) in control box assembly with bolts (6), washers (7), lockwashers (8), and nuts (9).

NOTE

When replacing sealant with new gasket, ensure all old sealant residue is completely removed.

- c. If gasket (15) was removed, install new gasket (15).
- d. Immediately install top panel (5) with bolts (1), flatwashers (2), lockwashers (3), and assembled nuts (4).
- e. Install control panel access door, paragraph 2-14-4.
- f. Connect negative battery cable. Close battery access door.

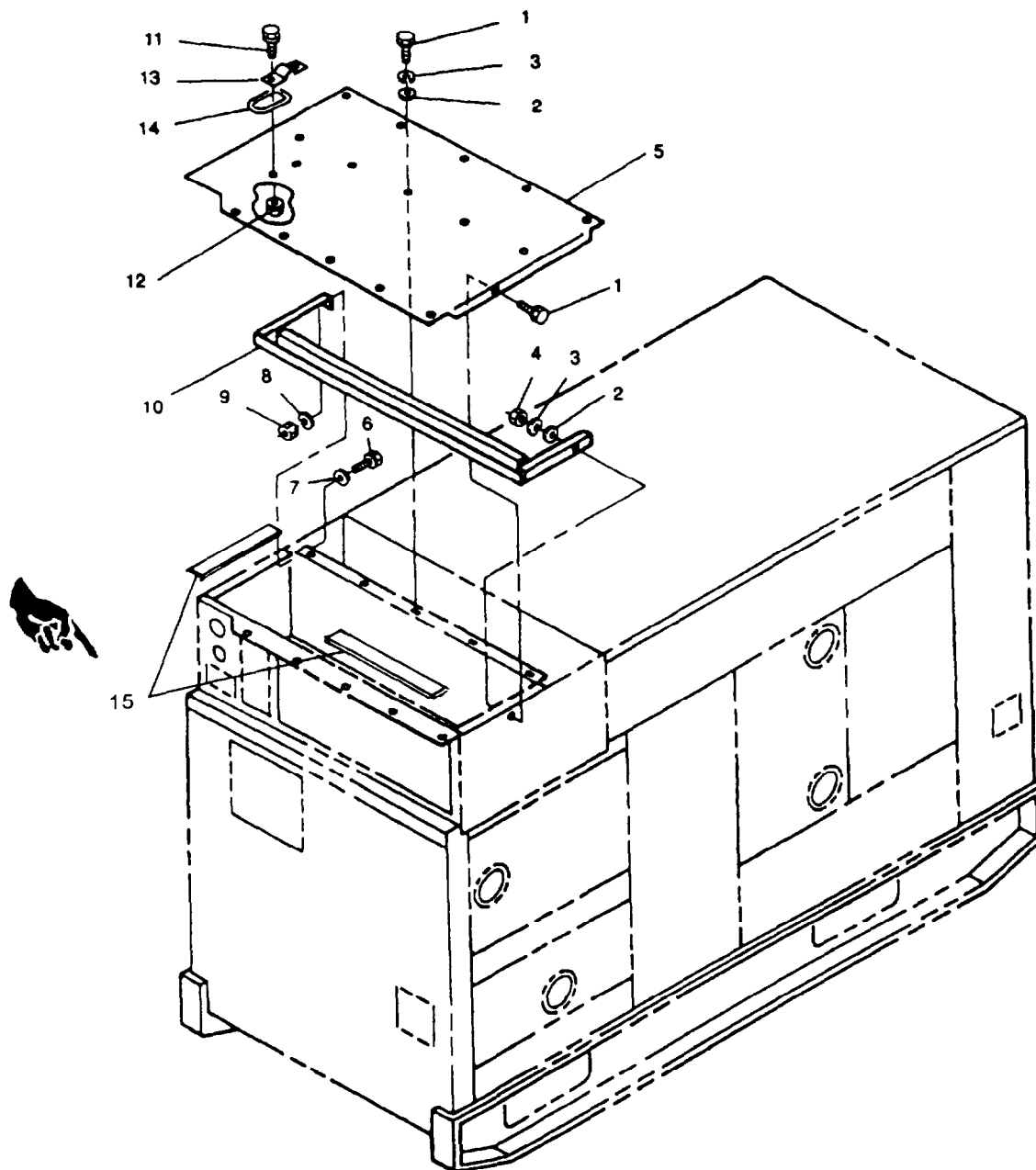

FIGURE 2-6. Control Box Top Panel

2-16 TOP HOUSINGS SECTION.

2-16-1 Removal.

- a. Shut down generator set.
- b. Remove control box assembly, paragraph 2-19-2.

WARNING

Top housing panels can get very hot. Allow panels to cool down before performing maintenance. Failure to observe this warning could result in severe burns.

- c. Remove bolts (1, FIGURE 2-7), flatwashers (3), lockwashers (2), mount (4), and exhaust cover (5) from top housing panel (6).
- d. Remove bolts (7) and (10), flatwashers (9) and (12), lockwashers (8) and (11), and top housing panel (6) from generator set.
- e. Disconnect radiator fill hose and overflow hose from radiator fill panel (13) and remove radiator fill panel (13) from generator set.
- f. Remove bolts (14), flatwashers (16), lockwashers (15), and frame (17) from generator set.
- g. Remove muffler, paragraph 2-71-1.
- h. Remove bolts (18), assembled nuts (19), and air duct channels (20) and (21).
- i. Remove bolts (22) and (24), assembled nuts (23) and (25), and panel (26).
- j. Remove bolts (27), (29), and (33); flatwashers (30) and (35); lockwashers (31) and (34); assembled nuts (28); nuts (32); and top side panels (36) and (37) with top section floor panel (38).
- k. Remove bolts (39), assembled nuts (40), and panel (41) from floor panel (38).
- l. Remove bolts (42), assembled nuts (43), and support (44) from panel (41).
- m. Remove bolts (45), assembled nuts (46), and side panels (36) and (37) from floor panel (38).
- n. Remove bolt (47), assembled nut (48), and bracket (49) from angle (52).
- o. Remove bolts (50), assembled nuts (51), and angle (52) from generator set. Open output box access door to reach nuts (51).
- p. Remove dip halves (53) and insulation (54) through (64) from top panel (6) as necessary.
- q. Remove dip halves (65) and insulation (66) and (67) from side panels (36) and (37) as necessary.

2-16-2 Inspection.

- a. Shut down generator set.
- b. Inspect all top housing section panels for dents, cracks, loose paint, and corrosion.
- c. Inspect all cage nuts (68, FIGURE 2-7) for cracking or stripped threads.

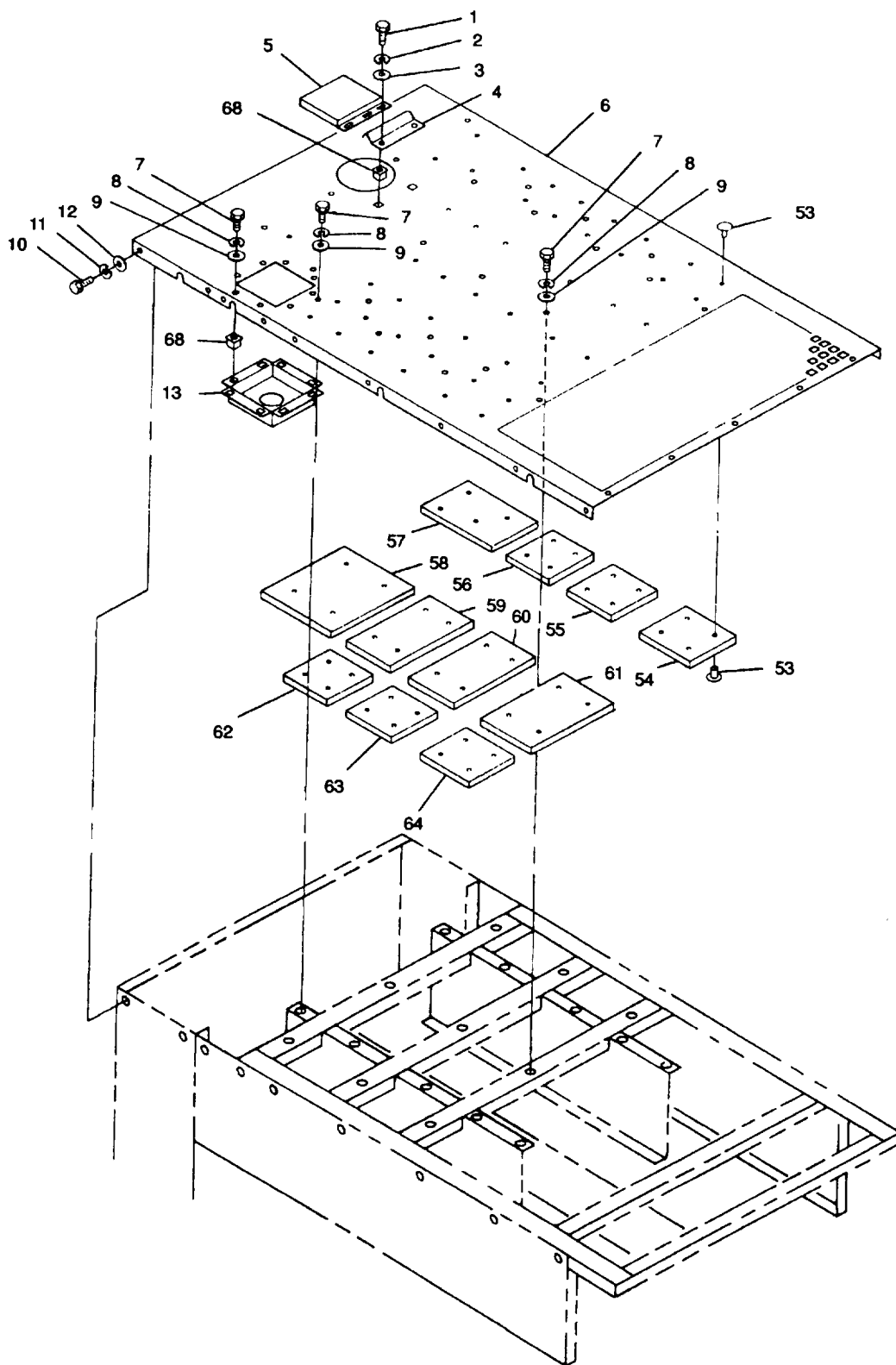

FIGURE 2-7. Generator Set Top Housing Section (Sheet 1 of 2)

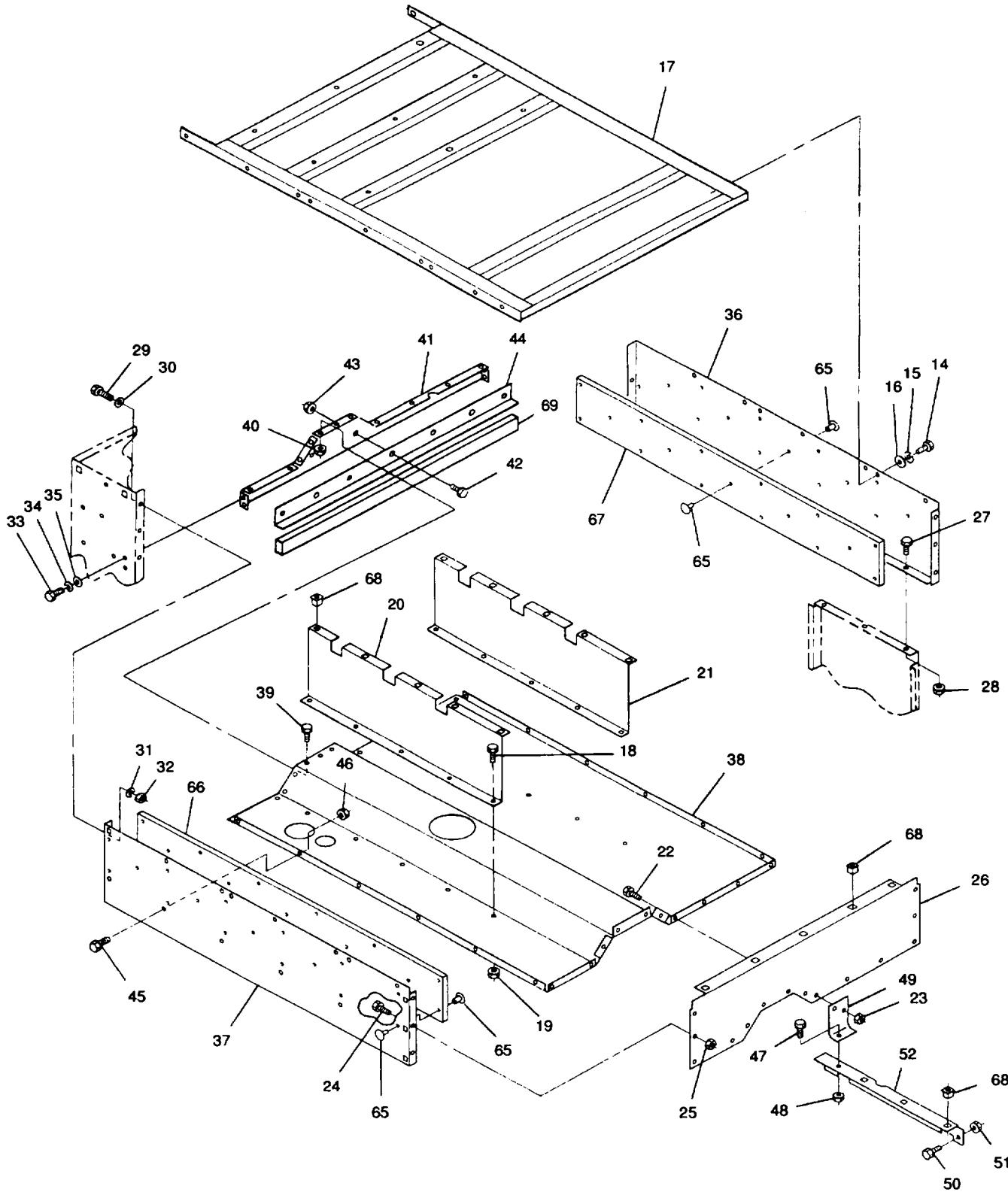

FIGURE 2-7. Generator Set Top Housing Section (Sheet 2 of 2)

- d. Inspect sound insulation for damage and missing dip halves.
- e. Inspect seal (69) for tears, looseness, and deterioration.

2-16-3 Repair.

WARNING

Wear a protective mask and gloves when sanding CARC painted surfaces. CARC paint dust is a health hazard and could cause personal injury if warning is not followed.

- a. Repair all dents and cracks, and remove all loose paint.
- b. Remove light corrosion with fine grit abrasive paper (Item 16, Appendix C).
- c. Repaint surfaces in accordance with TM 43-0139. (F) Refer to applicable directives.
- d. Replace any cage nuts (68, FIGURE 2-7) that are stripped or cracked.
- e. Replace damaged sound insulation and missing clip halves. Refer to Appendix D for fabrication of insulation.
- f. Replace loose or damaged seal (69).

2-16-4 Installation.

- a. Install angle (52, FIGURE 2-7) in generator set with bolts (50) and assembled nuts (51).
- b. Install bracket (49) to angle (52) with bolt (47) and assembled nut (48).
- c. Install insulation (54) through (64) on top panel (6) with dip halves (53) as required.
- d. Install insulation (66) and (67) on side panels (36) and (37) with clip halves (65) as required.
- e. Install top side panels (36) and (37) on top section floor panel (38) with bolts (45) and assembled nuts (46).
- f. Install support (44) on panel (41) with bolts (42) and assembled nuts (43).
- g. Install panel (41) on top section floor panel (38) with bolts (39) and assembled nuts (40).
- h. Position top section floor panel (38), with side and front panels attached, in generator set and secure with bolts (27), (29), and (33); flatwashers (30) and (35); lockwashers (31) and (34); assembled nuts (28); and nuts (32).
- i. Install panel (26) with bolts (22) and (24), and assembled nuts (23) and (25).
- j. Install air duct channels (20) and (21) with bolts (18) and assembled nuts (19).
- k. Install muffler, paragraph 2-71-3.
- l. Install frame (17) with bolts (14), flatwashers (16), and lockwashers (15).
- m. Install radiator fill panel (13) in generator set and connect radiator fill hose and overflow hose to panel (1 3).
- n. Install top housing panel (6) with bolts (7) and (10), flatwashers (9) and (12), and lockwashers (8) and (11),
- o. Install mount (4) and exhaust cover (5) with bolts (1), flatwashers (3), and lockwashers (2).
- p. Install control box assembly, paragraph 2-19-4.

2-17 FRONT HOUSING SECTION.

2-17-1 Removal.

- a. Shut down generator set.
- b. Remove battery box access door, paragraph 2-14-1.
- c. Remove engine access doors, paragraph 2-14-1.
- d. Remove top housing section, paragraph 2-16-1.
- e. Remove batteries, paragraph 2-12-2 and slave receptacle, paragraph 2-13-2.
- f. Remove bolts (1, FIGURE 2-8) and ground rods (2) from brackets (54).
- g. Remove bolts (3), (6), and (10); flatwashers (5), (7), and (11); lockwashers (4),(8), and (12); nuts (9) and (13); and front panel (14) from generator set.
- h. Remove bolts (15) and (18), flatwashers (17) and (19), lockwashers (16) and (20), nuts (21), and side panels (22) and (23) from generator set.
- i. Remove dip halves (24) and insulation (25) from front panel (14).
- j. Remove bolts (26) and (29), washers (28), lockwashers (27), assembled nuts (30), and air deflector (31) from front panel (14).
- k. Remove bolts (32), lockwashers (33), washers (34), and panels (35) and (36) from front panel (14).
- l. Remove bolts (37), assembled nuts (38), and supports (39) and (40) from panels (35) and (36).
- m. Remove bolts (41) and panel (42) from front panel (14).
- n. Remove bolts (43), assembled nuts (44), and support (45) from panel (42).
- o. Remove bolts (46), assembled nuts (47), and support channel (48) from front panel (14).
- p. Remove bolts (49), assembled nuts (50), and slave receptacle box (51) from front panel (14).
- q. Remove bolts (52), assembled nuts (53), and brackets (54) from panels (14) and (22).
- r. If necessary, drill out rivets (55), (56), and (57); remove identification plates (58), (59), and (60).

2-17-2 Inspection.

- a. Shut down generator set.
- b. Inspect all front housing section panels for dents, cracks, loose paint, corrosion, and other damage.
- c. Inspect all cage nuts (61, FIGURE 2-8) for cracking or stripped threads.
- d. Inspect insulation for damage and missing dip halves.
- e. Inspect seals (62) and (63) for tears, looseness, and deterioration.

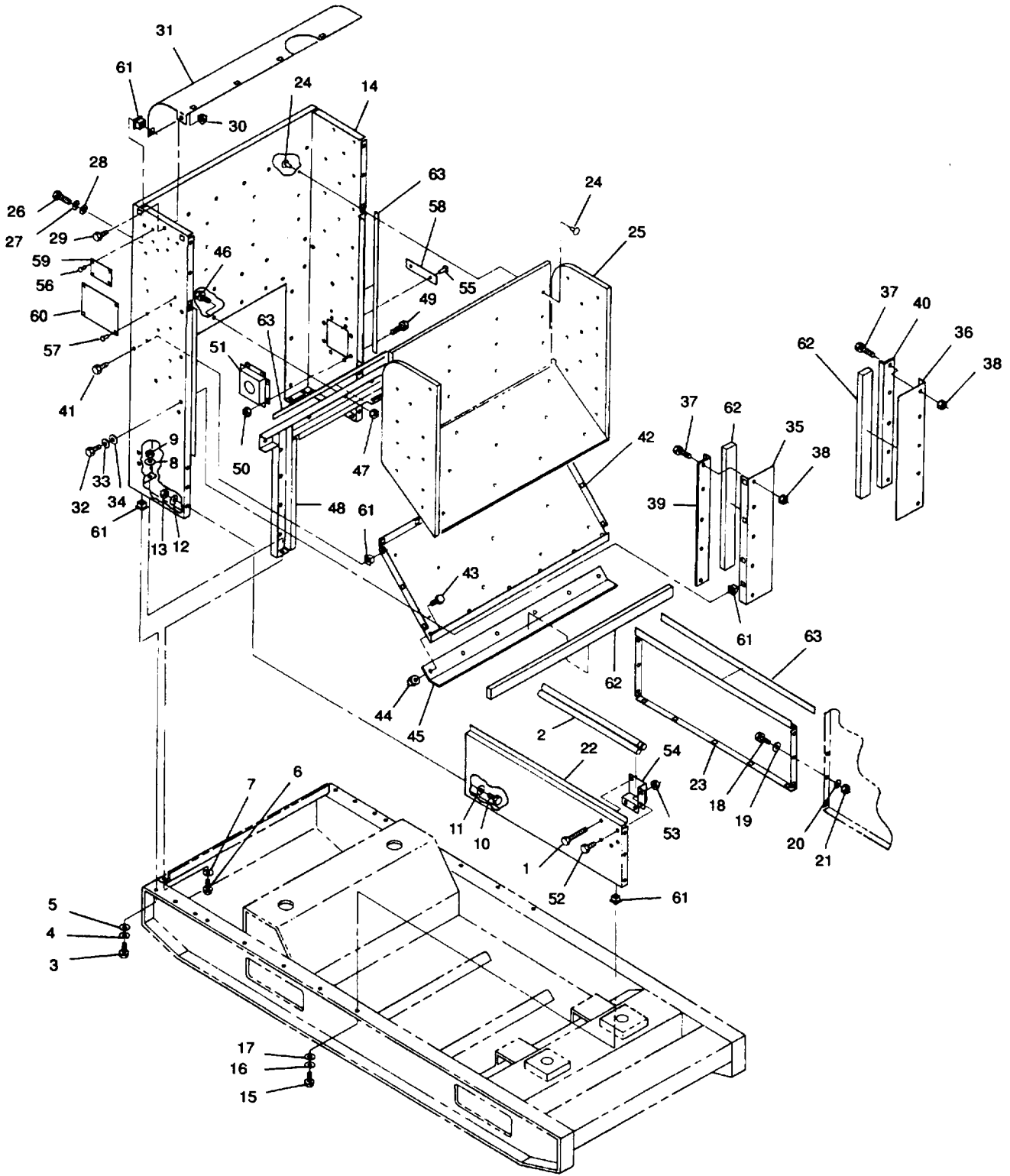

FIGURE 2-8. Generator Set Front Housing Section

2-17-3 Repair.

WARNING

Wear a protective mask and gloves when sanding CARC painted surfaces. CARC paint dust is a health hazard and could cause personal injury if warning is not followed.

- a. Repair all dents and cracks, and remove all loose paint.
- b. Remove light corrosion with fine grit abrasive paper (Item 16, Appendix C).
- c. Repaint surfaces in accordance with TM 43-0139. (F) Refer to applicable directives.
- d. Replace any cracked or stripped cage nuts (61, FIGURE 2-8).
- e. Replace damaged insulation and missing dip halves. Refer to Appendix D for fabrication of insulation.
- f. Replace loose or damaged seals (62) and (63).

2-17-4 **Installation**

- a. If removed, install identification plates (58, 59, and 60, FIGURE 2-8) on front panel (14) with rivets (55), (56), and (57).
- b. Install brackets (54) on panels (14) and (22) with bolts (52) and assembled nuts (53).
- c. Install slave receptacle box (51) on front housing panel (14) with bolts (49) and assembled nuts (50).
- d. Install side panels (22) and (23) on generator set with bolts (15) and (18), flatwashers (17) and (19), lockwashers (16) and (20), and nuts (21).
- e. Install support channel (48) on front panel (14) with bolts (46) and assembled nuts (47).
- f. Install support (45) on panel (42) with bolts (43) and assembled nuts (44).
- g. Install panel (42) on front panel (14) with bolts (41).
- h. Install supports (39) and (40) on panels (35) and (36) with bolts (37) and assembled nuts (38).
- i. Install panels (35) and (36) on front panel (14) with bolts (32), lockwashers (33), and washers (34).
- j. Install air deflector (31) on front panel (14) with bolts (26) and (29), washers (28), lockwashers (27), and assembled nuts (30).
- k. Install insulation (25) on front panel (14) with dip halves (24).
- l. Install front housing panel (14) on generator set with bolts (3), (6), and (10); flatwashers (5), (7), and (11); lockwashers (4) (8), and (12); and nuts (9) and (13).
- m. Install slave receptacle, paragraph 2-13-3 and batteries, paragraph 2-12-5.
- n. Install battery box access door and engine access doors, paragraph 2-14-4.
- o. Install top housing section, paragraph 2-16-4.
- p. Install ground rods (2) in brackets (54) and secure with bolts (1). Close all access doors.

2-18 REAR HOUSING SECTION.

2-18-1 Removal.

- a. Shut down generator set.
- b. Remove control box assembly, paragraph 2-19-2.
- c. Remove air cleaner assembly, paragraph 2-73-3.
- d. Remove output box access door and load terminal board access door, paragraph 2-14-1.
- e. Remove rear engine access doors and air cleaner access door, paragraph 2-14-1.
- f. Remove fuel filler neck, paragraph 2-88-1.
- g. Remove auxiliary fuel pump, paragraph 2-87-3.
- h. Remove fuel float module, paragraph 2-93-3.
- i. Remove ether solenoid valve, paragraph 2-95-1.
- j. Remove top housing panel, paragraph 2-16-1, step d.
- k. Remove bolts (1 and 4, FIGURE 2-9), flatwashers (3) and (5), lockwashers (2) and (6), nuts (7), and rear panel (8) from generator set.
- l. Remove bolts (9), assembled nuts (10), and load cable entrance box (11) from panel (8).
- m. Remove bolts (12) and (16), flatwashers(13) and (17), lockwashers (14) and (18), nuts (15), and left side rear panel (19) from generator set.
- n. Remove bolts (20), assembled nuts (21), and baffle (22) from panel (1 9).
- o. Remove dip halves (23) and insulation (24) from baffle (22).
- p. Remove bolts (25), assembled nuts (26), and fuel filler neck panel (27) from panel (19).

NOTE

Ensure output box assembly is secured prior to removal of corner post and door sills,

- q. Remove bolts (28), (32), and (34); flatwashers (29); lockwashers (30); nuts (31); assembled nuts (33) and (35); comer post (36); and door sills (37) and (38) from generator set.
- r. Remove bolts (39), (42), (46), and (48); flatwashers (41) and (43); lockwashers (40) and (44); nuts (45); assembled nuts (47) and (49); and right side panel (50) from generator set.
- s. If necessary, drill out rivets (51) and remove plate (52) from side panel (19).
- t. If necessary, drill out rivets (53) and remove plate (54) from fuel filler neck panel (27).
- u. If necessary, remove output box EMI seals (55) from door sill (37), comer post (36), and right side panel (50).

2-18-2 Inspection.

- a. Shut down generator set.
- b. Inspect rear housing section panels for dents, cracks, loose paint, corrosion, and other damage.
- c. Inspect all cage nuts (57, FIGURE 2-9) for cracking or stripped threads.

- d. Inspect all insulation for damage and missing dip halves.
- e. Inspect EMI seals (55) for tears, looseness, and deterioration.
- f. Inspect door seals (56) for tears, looseness, and deterioration.

2-18-3 Repair.

WARNING

Wear a protective mask and gloves when sanding CARC painted surfaces. CARC paint dust is a health hazard and could cause personal injury if warning is not followed.

- a. Repair all dents and cracks, and remove all loose paint.
- b. Remove light corrosion with fine grit abrasive paper (Item 16, Appendix C).
- c. Repaint surfaces in accordance with TM 43-0139. (F) Use applicable directives.
- d. Replace all cracked or stripped cage nuts (57, FIGURE 2-9).
- e. Replace damaged insulation (24) and missing dip halves (23). Refer to Appendix D for fabrication of insulation.
- f. Replace EMI seals (55) that are loose or show any evidence of damage.
- g. Replace damaged door seals (56).

2-18-4 Installation.

- a. If removed, install plate (54, FIGURE 2-9) on fuel filler neck panel (27) with rivets (53).
- b. If removed, install plate (52) on side panel (19) with rivets (51).
- c. Install right side panel (50) on generator set with bolts (39), (42),(46), and (48); flatwashers (41) and (43); lockwashers (40) and (44); nuts (45); and assembled nuts (47) and (49).
- d. Install door sills (37) and (38), and comer post (36) on generator set with bolts (28), (32), and (34); flatwashers (29); lockwashers (30); nuts (31); and assembled nuts (33) and (35).
- e. Install fuel filler neck panel (27) on left side rear panel (19) with bolts (25) and assembled nuts (26).
- f. Install insulation (24) on baffle (22) with clip halves (23).
- g. Install baffle (22) on left side rear panel (19) with bolts (20) and assembled nuts (21).
- h. Install left side rear panel (19) on generator set with bolts (12) and (16), flatwashers (13) and (17), lockwashers (14) and (18), and nuts (15).
- i. Install load entrance box (11) on rear panel (8) with bolts (9) and assembled nuts (10).
- j. Install rear panel (8) on generator set with bolts (1) and (4), flatwashers (3) and (5), lockwashers (2) and (6), and nuts (7).

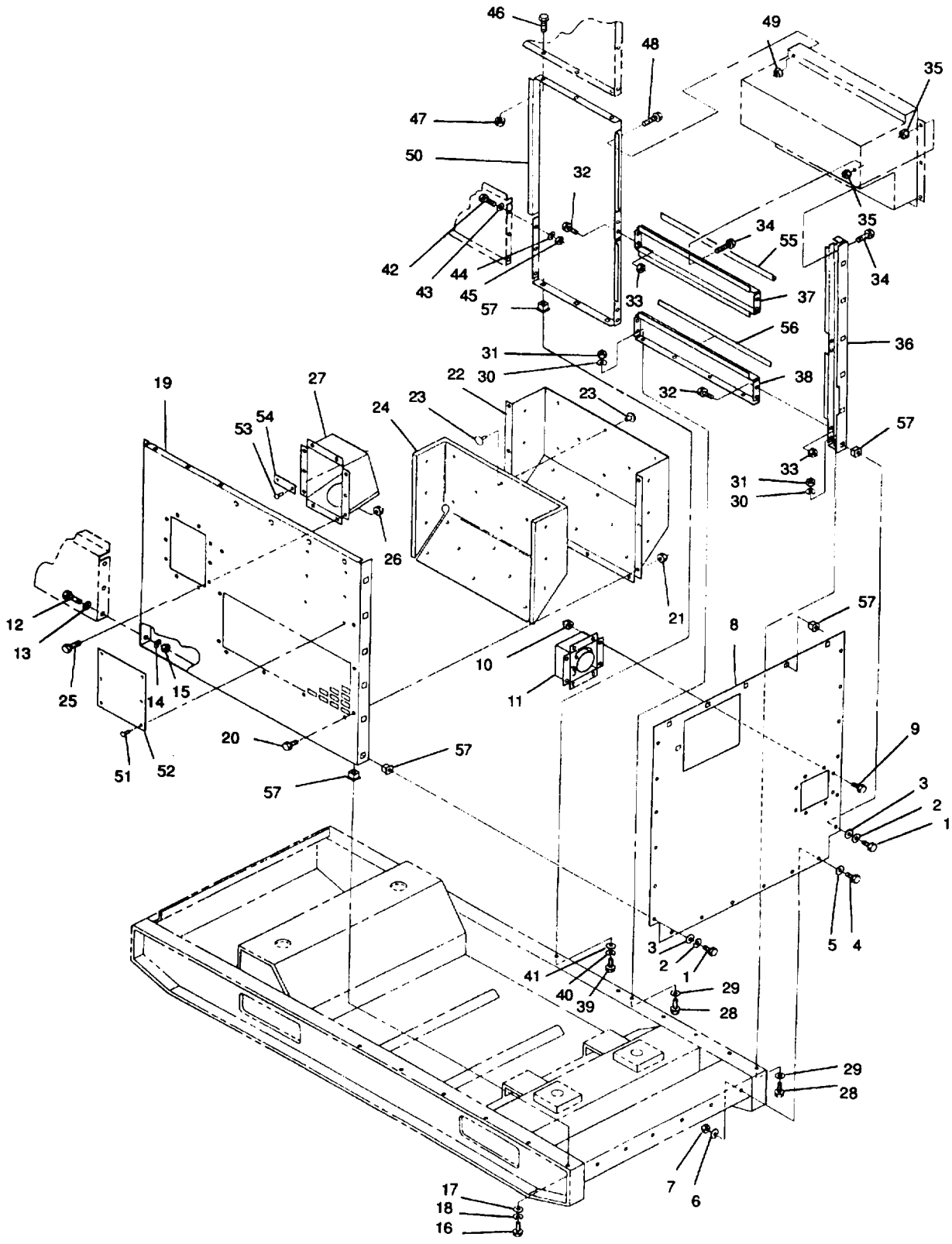

FIGURE 2-9. Generator Set Rear Housing Section

- k. If removed, install output box EMI seals (55) on door sill (37), corner post (36), and right side panel (50) with adhesive (Item 1, Appendix C). Ensure closed side of seal faces outward.
- l. Install top housing panel, paragraph 2-16-4, step n.
- m. Install ether solenoid valve, paragraph 2-95-3.
- n. Install fuel float module, paragraph 2-93-4.
- o. Install auxiliary fuel pump, paragraph 2-87-4.
- p. Install fuel filler neck, paragraph 2-88-3.
- q. Install air cleaner access door, rear engine access doors, paragraph 2-14-4.
- r. Install load terminal board access door and output box access door, paragraph 2-14-4.

NOTE

Output box EMI seals are primary suppression components. Ensure that a complete seal is made between output box door and generator set.

- s. Install air cleaner assembly, paragraph 2-73-4.
- t. Install control box assembly, paragraph 2-19-4.

Section X. MAINTENANCE OF CONTROL BOX ASSEMBLY

2-19 CONTROL BOX ASSEMBLY.

2-19-1 Inspection.

- a. Shut down generator set.
- b. Inspect control box assembly for cracks, breaks, corrosion, loose paint, and missing parts.

2-19-2 Removal.

- a. Shut down generator set.
- b. Open battery access door and disconnect negative battery cable.
- c. Remove control box top panel, paragraph 2-15-1.
- d. Open output box access door and disconnect two control box harness connectors.
- e. Remove bolts (1 and 5, FIGURE 2-1 0), lockwashers (2), flatwashers (3), nuts (4), and control box assembly (6) from generator set.

2-19-3 Repair.

Repair control box assembly by replacing damaged terminals, damaged or missing hardware, and damaged or defective components.

2-19-4 Installation

- a. Install control box assembly (6, FIGURE 2-10) on generator set with bolts (1) and (5), flatwashers (3), lockwashers (2), and nuts (4).
- b. Connect two control box harness connectors.

- c. Install control box top panel, paragraph 2-15-4.
- d. Connect negative battery cable. Close battery access door.

2-20 PANEL LIGHTS.

2-20-1 Inspection.

Inspect panel light holder and directional cap for cracks, corrosion, stripped threads, and other damage.

2-20-2 Removal.

- a. Shut down generator set.
- b. Open battery access door and disconnect negative battery cable.
- c. Release control panel by turning two fasteners and lower control panel slowly.
- d. Tag and disconnect panel light (1, FIGURE 2-11) electrical leads.
- e. Remove nut (2) and washer (3).
- f. Remove panel light (1) from control panel.

2-20-3 Disassembly.

- a. Remove panel light directional cap (4, FIGURE 2-11) from panel light housing (1).
- b. Remove panel light bulb (5).

2-20-4 Assembly.

- a. Install panel light bulb (5, FIGURE 2-11) into panel light housing (1).
- b. Install panel light directional cap (4).

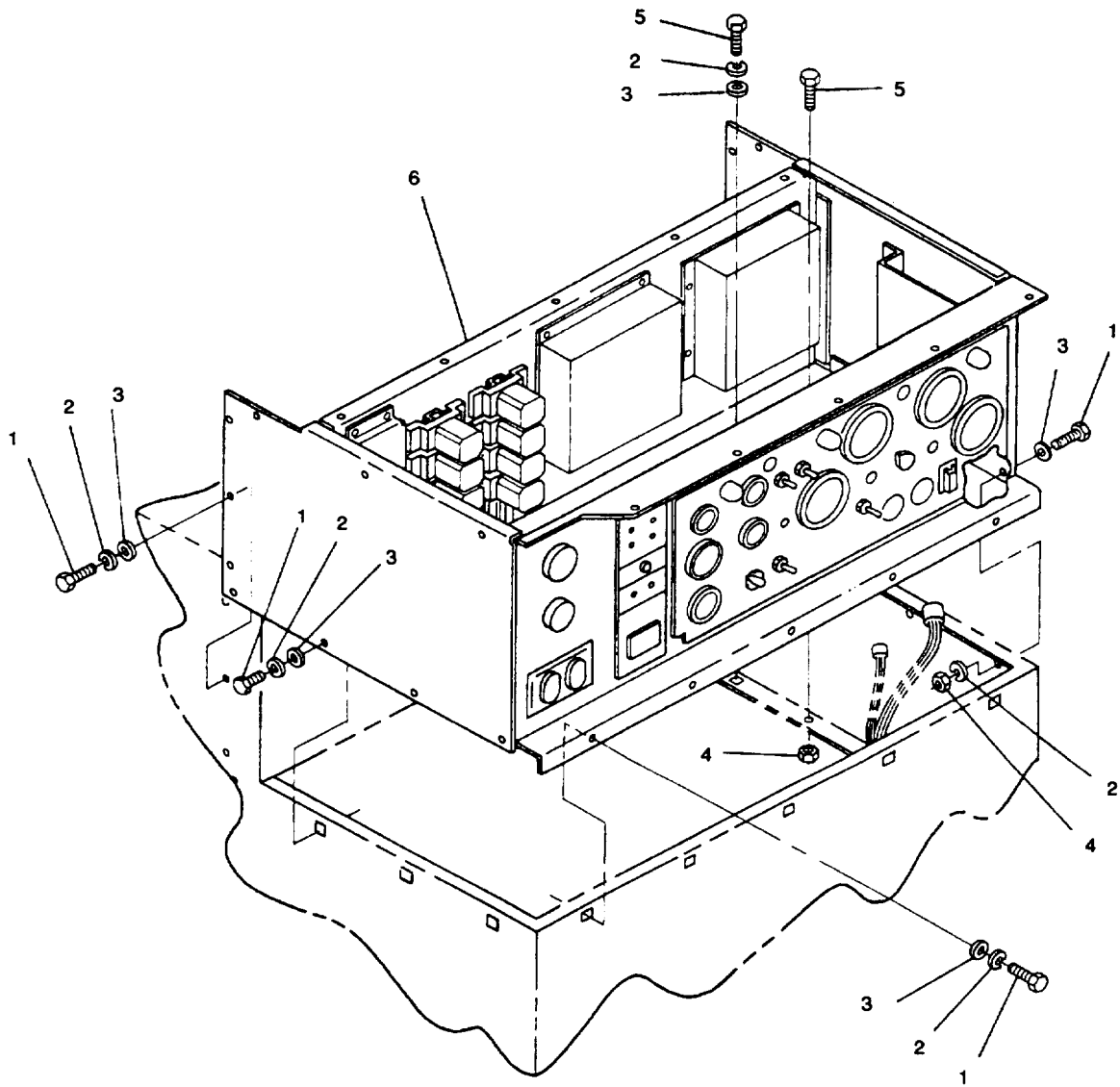

FIGURE 2-10. Control Box Assembly

2-20-5 Installation.

- a. Insert panel light (1, FIGURE 2-11) into control panel.
- b. Install washer (3) and nut (2).
- c. Connect panel light electrical leads and remove tags.
- d. Raise and secure control panel.
- e. Connect negative battery cable. Close battery access door.

2-21 PRESS TO TEST LIGHTS.

2-21-1 Inspection.

- a. Inspect lights for cracks, corrosion, evidence of shorting, and other damage.
- b. Replace or repair lights as necessary.

2-21-2 Testing.

- a. Place MASTER SWITCH in either PRIME& RUN position.
- b. Press in lamp holders (6, FIGURE 2-11) and check that lamps are lit.
- c. If lamp (7) fails to light perform steps d through g.
- d. Release control panel by turning two fasteners and lower control panel slowly.
- e. Set multimeter for DC volts and check for voltage at terminals 1 and 3 on receptacle (10).
- f. If voltage is present, replace press to test light assembly.
- g. Raise and secure control panel.

2-21-3 Removal.

- a. Shut down generator set.
- b. Open battery access door and disconnect negative battery cable.
- c. Release control panel by turning two fasteners and lower control panel slowly.
- d. Tag and disconnect electrical leads to light receptacles (10, FIGURE 2-11).
- e. Remove lamp holders (6), nuts (8), lockwashers (9), and receptacles (10) from control panel.
- f. If necessary, remove lamps (7) from lamp holders (6).

2-21-4 Installation.

- a. Install press to test light receptacles (10, FIGURE 2-11) in control panel with lockwashers (9) and nuts (8).
- b. If removed, install lamps (7) in lamp holders (6).
- c. Install lamp holders (6) on receptacles (10).
- d. Connect electrical leads and remove tags.
- e. Raise and secure control panel.

- f. Connect negative battery cable and close battery access door.

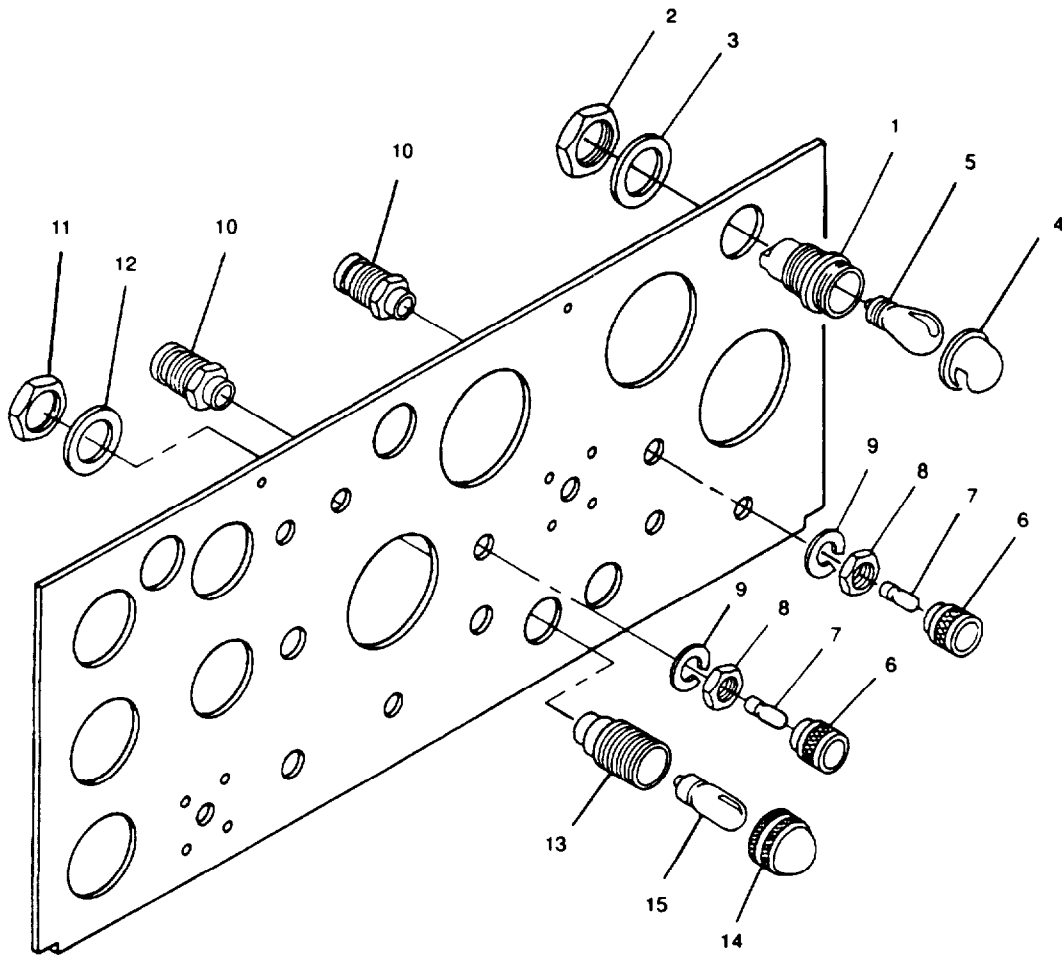

FIGURE 2-11. Control Panel Lights

2-22 SYNCHRONIZING LIGHTS.

2-22-1 Inspection.

Inspect synchronizing lights for cracks, corrosion, evidence of shorting, and other damage.

2-22-2 Removal.

- a. Shut down generator set.
- b. Open battery access door and disconnect negative battery cable.
- c. Release control panel by turning two fasteners and lower control panel slowly.
- d. Tag and disconnect synchronizing lights (13, FIGURE 2-11) electrical connections.
- e. Remove nuts (11) and washers (12).
- f. Remove synchronizing lights (13) from control panel.
- g. Unscrew lenses (14) and remove lamps (15) from light receptacles (13).

2-22-3 Installation.

- a. Insert synchronizing lights (13, FIGURE 2-11) into control panel.
- b. Install washers (12) and nuts (11).
- c. Connect electrical leads and remove tags.
- d. Raise and secure control panel.
- e. Install lamps (15) and screw lenses (14) on light receptacles (13).
- f. Connect negative battery cable. Close battery access door.

2-23 FUEL LEVEL INDICATOR.

2-23-1 Inspection.

- a. Shut down generator set.
- b. Inspect indicator for broken lens, cracked housing, and other damage.

2-23-2 Testing.

- a. Shut down generator set.
- b. Open battery access door and disconnect negative battery cable.
- c. Release control panel by turning two fasteners and lower control panel slowly.

NOTE

On MEP-805A, ensure frequency selector switch is in 50 Hz position.

- d. Isolate generator set VOLTAGE adjust potentiometer by disconnecting wire 137A from voltage regulator, terminal 5, and wire 107G from kilowatt transducer, terminal V1.
- e. Disconnect and isolate electrical lead from terminal S of FUEL LEVEL indicator.
- f. Set multimeter for ohms and connect between wires 137A and 107G.
- g. Adjust potentiometer until multimeter indicates between 216 and 264 ohms resistance.
- h. Remove multimeter, but do not disturb potentiometer adjustment.
- i. Connect jumper wire between disconnected wire 107G and terminal G of FUEL LEVEL indicator.
- j. Connect jumper wire between disconnected wire 137A and terminal S of FUEL LEVEL indicator.
- k. Connect negative battery cable and move generator set MASTER SWITCH to PRIME & RUN position.
- l. FUEL LEVEL indicator should indicate EMPTY ($\pm 1/8$ inch).
- m. Move MASTER SWITCH to OFF position and disconnect negative battery cable.
- n. Repeat steps f through h, setting potentiometer to between 29.7 and 36.3 ohms.
- o. Connect negative battery cable and move MASTER SWITCH to PRIME & RUN position.
- p. FUEL LEVEL indicator should indicate FULL ($\pm 1/8$ inch).

- q. Move MASTER SWITCH to OFF position and disconnect negative battery cable.
- r. Replace FUEL LEVEL indicator if it fails to function properly.
- s. Remove jumper wires and connect electrical leads to FUEL LEVEL indicator, voltage regulator and kilowatt transducer.
- t. Raise and secure control panel.
- u. Connect negative battery cable and close access doors.

2-23-3 Removal.

- a. Shut down generator set.
- b. Open battery access door and disconnect negative battery cable.
- c. Release control panel by turning two fasteners and lower control panel slowly.
- d. Tag and disconnect FUEL LEVEL indicator (4, FIGURE 2-12) electrical leads.
- e. Remove nuts (1), washers (2), and clamp (3).
- f. Remove FUEL LEVEL indicator (4) from control panel.

2-23-4 Installation.

- a. Insert FUEL LEVEL indicator (4, FIGURE 2-12) into control panel.
- b. Install clamp (3), washers (2) and nuts (1).
- c. Connect electrical leads and remove tags.
- d. Raise and secure control panel.
- e. Connect negative battery cable. Close battery access door.

2-24 COOLANT TEMP. INDICATOR.

2-24-1 Inspection.

- a. Shut down generator set.
- b. Inspect indicator for broken lens, cracked housing, or other damage.

2-24-2 Testing.

- a. Shut down generator set.
- b. Open battery access door and disconnect negative battery cable.
- c. Release control panel by turning two fasteners and lower control panel slowly.

NOTE

On MEP-805A, ensure frequency selector switch is in 50 Hz position.

- d. Isolate generator set VOLTAGE adjust potentiometer by disconnecting wire 137A from voltage regulator, terminal 5, and wire 107G from kilowatt transducer, terminal V1.
- e. Disconnect and isolate electrical lead from terminal S of COOLANT TEMP. indicator.

- f. Set multimeter for ohms and connect between wires 137A and 107G.
- g. Adjust potentiometer until multimeter indicates between 117 and 143 ohms resistance.
- h. Disconnect multimeter but do not disturb potentiometer setting.
- i. Connect jumper wire between disconnected wire 107G and terminal G of COOLANT TEMP. indicator.
- j. Connect jumper wire between disconnected wire 137A and terminal S of COOLANT TEMP. indicator.
- k. Connect negative battery cable and move generator set MASTER SWITCH to PRIME & RUN position.
- l. COOLANT TEMP. indicator should indicate between 116 and 164°F.
- m. Move MASTER SWITCH to OFF position and disconnect negative battery cable.
- n. Repeat steps f through h, setting potentiometer to between 58.5 and 71.5 ohms.
- o. Connect negative battery cable and move MASTER SWITCH to PRIME & RUN position.
- p. COOLANT TEMP. indicator should indicate between 156 and 204°F.
- q. Move MASTER SWITCH to OFF position and disconnect negative battery cable.
- r. Replace COOLANT TEMP. indicator if indications are other than above.
- s. Remove jumper wires and connect electrical leads to COOLANT TEMP. indicator, voltage regulator and kilowatt transducer.
- t. Raise and secure control panel.
- u. Connect negative battery cable and close access doors.

2-24-3 Removal.

- a. Shut down generator set.
- b. Open battery access door and disconnect negative battery cable.
- c. Release control panel by turning two fasteners and lower control panel slowly.
- d. Tag and disconnect COOLANT TEMP. indicator (8, FIGURE 2-12) electrical leads.
- e. Remove nuts (5), washers (6), and clamp (7).
- f. Remove COOLANT TEMP. indicator (8) from control panel.

2-24-4 Installation.

- a. Insert COOLANT TEMP indicator (8, FIGURE 2-12) in control panel
- b. Install clamp (7), washers (6), and nuts (5).
- c. Connect electrical leads and remove tags.
- d. Raise and secure control panel.
- e. Connect negative battery cable. Close battery access door.

2-25 OIL PRESSURE INDICATOR.

2-25-1 Inspection.

- a. Shut down generator set.
- b. Inspect indicator for broken lens, cracked housing, or other damage.

2-25-2

- a. Shut down generator set.
- b. Open battery access door and disconnect negative battery cable.
- c. Release control panel by turning two fasteners and lower control panel slowly.

NOTE

On MEP-805A, ensure frequency selector switch is in 50 Hz position.

- d. isolate generator set VOLTAGE adjust potentiometer by disconnecting wire 137A from voltage regulator, terminal 5, and wire 107G from kilowatt transducer, (40, FIGURE 2-14) terminal V1.
- e. Disconnect and isolate electrical lead from terminal S of OIL PRESSURE indicator.
- f. Set multimeter for ohms and connect between wires 137A and 107G.
- g. Adjust potentiometer until multimeter indicates between 92.7 and 113.3 ohms resistance.
- h. Disconnect multimeter, but do not disturb potentiometer adjustment.
- i. Connect jumper wire between disconnected wire 107G and terminal G of OIL PRESSURE indicator.
- j. Connect jumper wire between disconnected wire 137A and terminal S of OIL PRESSURE indicator.
- k. Connect negative battery cable and move MASTER SWITCH to PRIME & RUN position.
- l. OIL PRESSURE indicator should indicate between 32 and 48 PSI.
- m. Move MASTER SWITCH to OFF position and disconnect negative battery cable.
- n. Repeat steps f through h, setting potentiometer to between 30.15 and 36.85 ohms.
- o. Connect negative battery cable and move MASTER SWITCH to PRIME & RUN position.
- p. OIL PRESSURE indicator should indicate between 72 and 80 PSI.
- q. Move MASTER SWITCH to OFF position and disconnect negative battery cable.
- r. Replace OIL PRESSURE indicator if it does not function properly.
- s. Remove jumper wires and connect electrical leads to OIL PRESSURE indicator, voltage regulator, and kilowatt transducer.
- t. Raise and secure control panel.
- u. Connect negative battery cable and close access doors.

2-25-3 Removal.

- a. Shut down generator set.

- b. Open battery access door and disconnect negative battery cable.
- c. Release control panel by turning two fasteners and lower control panel slowly.
- d. Tag and disconnect OIL PRESSURE indicator (12, FIGURE 2-12) electrical leads
- e. Remove nuts (9), washers (10), and clamp (11).
- f. Remove OIL PRESSURE indicator (12) from control panel.

2-25-4 Installation.

- a. Insert OIL PRESSURE indicator (12, FIGURE 2-12) into control panel,
- b. Install clamp (11), washers (10), and nuts (9).
- c. Connect electrical leads and remove tags.
- d. Raise and secure control panel.
- e. Connect negative battery cable. Close battery access door.

2-26 TIME METER (TOTAL HOURS).

2-26-1 Inspection.

- a. Shut down generator set.
- b. Inspect meter for broken lens, cracked housing, and other damage.

2-26-2 Testing.

- a. Release control panel by turning two fasteners and lower control panel slowly.
- b. Turn MASTER SWITCH to PRIME & RUN position.
- c. Crank engine momentarily to energize time meter relay.
- d. Set multimeter for DC volts and connect across terminals 1 and 2 of time meter (TOTAL HOURS).
- e. If 24 VDC is present, wait approximately 6 minutes. Time meter (TOTAL HOURS) should move 1/10 of an hour.
- f. If time meter (TOTAL HOURS) does not operate properly, meter is defective and must be replaced.
- g. Raise and secure control panel.

2-26-3 Removal.

- a. Shut down generator set.
- b. Open battery access door and disconnect negative battery cable.
- c. Release control panel by turning two fasteners and lower control panel slowly.
- d. Tag and disconnect time meter (TOTAL HOURS) (15, FIGURE 2-12) electrical leads.
- e. Remove screws (14), washers (32), and nuts (13).
- f. Remove time meter (TOTAL HOURS) (15) from control panel.

2-26-4 Installation.

- a. Insert time meter (TOTAL HOURS) (15, FIGURE 2-12) into control panel.

- b. Install screws (14), washers (32), and nuts (13).
- c. Connect electrical leads and remove tags.
- d. Raise and secure control panel.
- e. Connect negative battery cable. Close battery access door.

2-27 BATTERY CHARGE AMMETER.

2-27-1 Inspection.

- a. Shut down generator set.
- b. Inspect ammeter for broken lens, cracked housing and other damage.

2-27-2 Testing.

- a. Start and operate generator set at rated voltage and frequency.
- b. Release control panel by turning two fasteners and lower control panel slowly.
- c. Set multimeter for DC volts and connect across BATTERY CHARGE ammeter terminals. Connect positive lead to positive terminal and negative lead to negative terminal if you observe or think battery is charging. Multimeter should indicate up to 50 mv (25 mv equals + 10 amps on BATTERY CHARGE ammeter).
- d. Reverse multimeter leads if you observe or think battery is discharging. Multimeter should indicate up to 25 mv (25 mv equals -10 amps on BATTERY CHARGE ammeter).
- e. If multimeter indicates millivolt reading and BATTERY CHARGE ammeter is not within + 10% of equal ampere reading, or ammeter is not indicating, replace BATTERY CHARGE ammeter.
- f. Raise and secure control panel.

2-27-3 Removal.

- a. Shut down generator set.
- b. Open battery access door and disconnect negative battery cable.

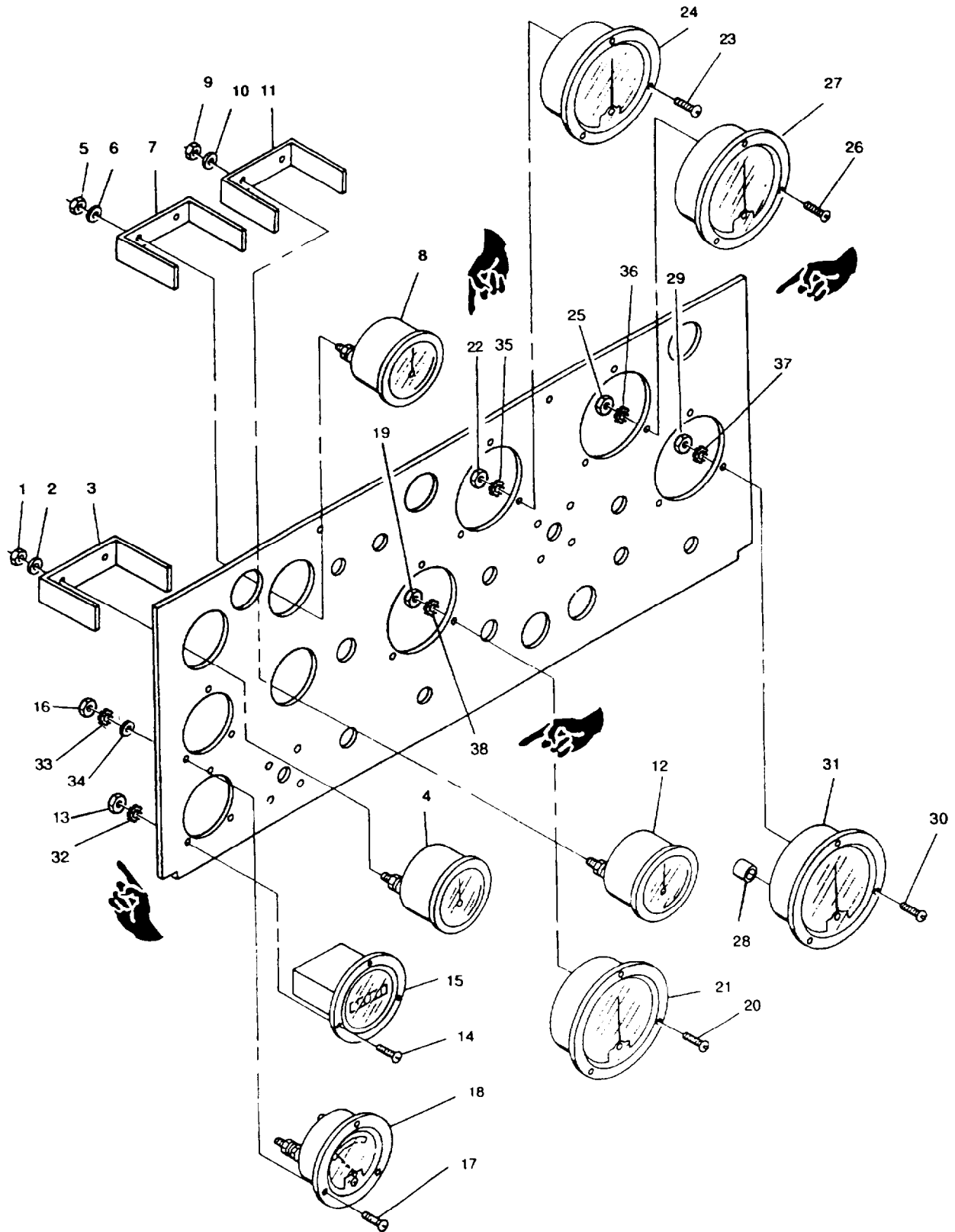

FIGURE 2-12. Control Panel Indicators

- c. Release control panel by turning two fasteners and lower control panel slowly.
- d. Tag and disconnect BATTERY CHARGE ammeter (18, FIGURE 2-12) electrical leads.
- e. Remove nuts (16) and screws (17), and washers (33, 34).
- f. Remove BATTERY CHARGE ammeter (18).

2-27-4 Installation.

- a. Insert BATTERY CHARGE ammeter (18, FIGURE 2-12) into control panel.
- b. Install screws (17), washers (33, 34), and nuts (16).
- c. Connect electrical leads and remove tags.
- d. Raise and secure control panel.
- e. Connect negative battery cable. Close battery access door.

2-28 FREQUENCY METER (HERTZ).

2-28-1 Inspection.

- a. Shut down generator set.
- b. Inspect meter for broken lens, cracked housing, and other damage.

2-28-2 Testing (50/60 Hz).

NOTE

Test frequency transducer in accordance with paragraph 2-52-2 or 2-52-3 prior to testing FREQUENCY meter (HERTZ).

- a. Shut down generator set.
- b. Open battery access door and disconnect negative battery cable.
- c. Release control panel by turning two fasteners and lower control panel slowly.
- d. Disconnect wire 181A from positive (+) terminal of FREQUENCY meter (HERTZ).
- e. Set multimeter for DC millamps and connect negative lead to positive (+) terminal of FREQUENCY meter (HERTZ) and positive lead to wire 181A.
- f. Position FREQUENCY SELECT switch to 60 Hz.
- g. Connect negative battery cable, start and operate generator set at rated voltage and adjust frequency to 60 Hz.
- h. Multimeter indication should be between 0.781 and 0.923 DC milliamps.
- i. Position FREQUENCY SELECT switch to 50 Hz and adjust frequency to 50 Hz.
- j. Multimeter indication should be between 0.071 and 0.213 DC milliamps.
- k. Replace FREQUENCY meter (HERTZ) if meter readings are not as stated above.
- l. Raise and secure control panel.

2-28-3 Testing (400 Hz).

- a. Shut down generator set

- b. Open battery access door and disconnect negative battery cable.
- c. Release control panel by turning two fasteners and lower control panel slowly.
- d. Disconnect wire 181A from positive (+) terminal of FREQUENCY meter (HERTZ).
- e. Set multimeter for DC milliamps and connect positive lead to positive (+) terminal of FREQUENCY meter (HERTZ) and negative lead to wire 181A.
- f. Connect negative battery cable, start and operate generator set at rated voltage and adjust frequency to 400 Hz.
- g. Multimeter indication should be between 0.240 and 0.260 DC milliamps.
- h. Replace FREQUENCY meter (HERTZ) if multimeter readings are not as stated above.
- i. Raise and secure control panel.

2-28-4 Removal.

- a. Shut down generator set.
- b. Open battery access door and disconnect negative battery cable.
- c. Release control panel by turning two fasteners and lower control panel slowly.
- d. Tag and disconnect FREQUENCY meter (HERTZ) (21, FIGURE 2-12) electrical leads.
- e. Remove nuts (19), washers (38), and screws (20).
- f. Remove FREQUENCY meter (HERTZ) (21) from control panel.

2-28-5 Installation.

- a. Insert FREQUENCY meter (HERTZ) (21, FIGURE 2-12) into control panel.
- b. Install screws (20), washers (38), and nuts (19).
- c. Connect electrical leads and remove tags.
- d. Raise and secure control panel.
- e. Connect negative battery cable. Close battery access door.

2-29 AMMETER (PERCENT RATED CURRENT).

2-29-1 Inspection.

- a. Shut down generator set.
- b. Inspect ammeter for broken lens, cracked housing, and other damage.

2-29-2 Testing.

- a. Shut down generator set.
- b. Open battery access door and disconnect negative battery cable.
- c. Release control panel by turning two fasteners and lower control panel slowly.
- d. Tag and disconnect wire 183A from terminal 1 of ammeter (PERCENT RATED CURRENT).

- e. Set multimeter for AC amperes and connect between disconnected wire 183A and terminal 1 of ammeter (PERCENT RATED CURRENT). Place AM-VM transfer switch in L1 - LO position.
- f. Connect negative battery cable, start and operate generator set at rated voltage and frequency. Apply some load to generator set.
- g. Observe and note indications on multimeter and ammeter (PERCENT RATED CURRENT).
- h. Shut down generator set.
- i. Calculate the percent of current from the multimeter indication using the following formula:

Percent of Current =

$$\frac{100 \times \text{Multimeter Indication}}{0.75 \text{ amperes}}$$

- j. Compare calculated percent of current to ammeter (PERCENT RATED CURRENT) indication noted during operation. If difference is greater than 10%, replace ammeter.
- k. Disconnect negative battery cable.
- l. Remove multimeter, connect wire 183A to ammeter (PERCENT RATED CURRENT).
- m. Raise and secure control panel.
- n. Connect negative battery cable and close battery access door.

2-29-3

Removal.

- a. Shut down generator set.
- b. Open battery access door and disconnect negative battery cable.
- c. Release control panel by turning two fasteners and lower control panel slowly.
- d. Tag and disconnect ammeter (PERCENT RATED CURRENT) (24, FIGURE 2-12) electrical leads.
- e. Remove nuts (22), washers (35), and screws (23).
- f. Remove ammeter (PERCENT RATED CURRENT) (24) from control panel.

2-29-4 **Installation.**

- a. Insert ammeter (PERCENT RATED CURRENT) (24, FIGURE 2-12) into control panel.
- b. Install screws (23), washers (35), and nuts (22).
- c. Connect electrical leads and remove tags.
- d. Raise and secure control panel.
- e. Connect negative battery cable. Close battery access door.

2-30 **KILOWATTMETER (PERCENT POWER).**

2-30-1 **Inspection.**

- a. Shut down generator set.
- b. Inspect meter for broken lens, cracked housing, and other damage.

2-30-2 Testing.

- a. Shut down generator set.
- b. Open battery access door and disconnect negative battery cable.
- c. Release control panel by turning two fasteners and lower control panel slowly.
- d. Tag and disconnect wire 120A from positive terminal of kilowattmeter (PERCENT POWER).
- e. Set multimeter for milliamperes and connect between disconnected wire 120A and positive terminal of kilowattmeter.
- f. Connect negative battery cable, start and operate generator set at rated voltage and frequency. Apply some load to generator set.
- g. Observe and note indications on multimeter and kilowattmeter.
- h. Shut down generator set.
- i. Calculate the percent of power from multimeter indication using the following formula:

Percent of power =

$$\frac{133 \times \text{Multimeter indication}}{1.2 \text{ Ma.}}$$

- j. Compare calculated percent of power to kilowattmeter indication noted during operation. If difference is greater than 13%, replace kilowattmeter (PERCENT POWER).
- k. Disconnect negative battery cable.
- l. Remove multimeter and connect wire 120A to kilowattmeter (PERCENT POWER).
- m. Raise and secure control panel.
- n. Connect negative battery cable and close battery access door.

2-30-3 Removal.

- a. Shut down generator set.
- b. Open battery access door and disconnect negative battery cable.
- c. Release control panel by turning two fasteners and lower control panel slowly.
- d. Tag and disconnect kilowattmeter (PERCENT POWER) (27, FIGURE 2-12) electrical leads.
- e. Remove nuts (25), washers (36), and screws (26).
- f. Remove kilowattmeter (PERCENT POWER) (27) from control panel.

2-30-4 Installation.

- a. Insert kilowattmeter (PERCENT POWER) (27, FIGURE 2-12) into control panel.
- b. Install screws (26), washers (36), and nuts (25).
- c. Connect electrical leads and remove tags.
- d. Raise and secure control panel.
- e. Connect negative battery cable. Close battery access door.

2-31 AC VOLTMETER (VOLTS AC).

2-31-1 Inspection.

- a. Shut down generator set.
- b. Inspect AC Voltmeter (VOLTS AC) for broken lens, cracked housing, and other damage.

2-31-2 Testing.

- a. Shut down generator set.
- b. Release control panel by turning two fasteners and lower control panel slowly.
- c. Set multimeter for AC volts and connect to AC Voltmeter (VOLTS AC) terminals.
- d. Move voltage reconnection board to 120/208 position.
- e. Start and operate generator set at rated voltage and frequency.
- f. Move AM/VM transfer switch to L3-L1 position. Note indications on multimeter and AC Voltmeter (VOLTS AC).
- g. Move AM/VM transfer switch to L3-L0 position. Note indications on multimeter and AC Voltmeter (VOLTS AC).
- h. Shut down generator set.
- i. Move voltage reconnection board to 240/416 position.
- j. Start and operate generator set at rated voltage and frequency.
- k. Repeat steps e and f.
- l. Shut down generator set.
- m. Compare AC Voltmeter (VOLTS AC) readings to multimeter in each position.
- n. Replace AC Voltmeter (VOLTS AC) if readings differ more than + 5 VAC between 115-125 VAC or + 10 VAC between 200-250 VAC.
- o. Remove multimeter.
- p. Raise and secure control panel.

2-31-3 Removal.

- a. Shut down generator set.
- b. Open battery access door and disconnect negative battery cable.
- c. Release control panel by turning two fasteners and lower control panel slowly.
- d. Tag and disconnect AC Voltmeter (VOLTS AC) (31, FIGURE 2-12) electrical leads and remove sleeves (28).
- e. Remove nuts (29), washers (37), and screws (30).
- f. Remove AC Voltmeter (VOLTS AC) (31) from control panel.

2-31-4 Installation.

- a. Insert AC Voltmeter (VOLTS AC) (31, FIGURE 2-12) into control panel.
- b. Install screws (30), washers (37), and nuts (29).

- c. Connect electrical leads, remove tags, and install sleeves (28) over terminals
- d. Raise and secure control panel.
- e. Connect negative battery cable. Close battery access door.

2-32 MASTER SWITCH.

2-32-1 Inspection.

- a. Shut down generator set.
- b. Inspect switch for loose connections and mounting, and other damage.

2-32-2 Removal.

- a. Shut down generator set.
- b. Open battery access door and disconnect negative battery cable.
- c. Release control panel by turning two fasteners and lower control panel slowly.
- d. Loosen setscrew (1, FIGURE 2-13) and remove knob (2) from MASTER SWITCH (5).
- e. Remove nuts (3) and screws (4).
- f. Remove MASTER SWITCH (5) from control panel.
- g. Tag and disconnect MASTER SWITCH (5) electrical leads.

2-32-3 Testing

- a. Shut down generator set.
- b. Open battery access door and disconnect negative battery cable.
- c. Release control panel by turning two fasteners and lower control panel slowly.
- d. Tag and disconnect MASTER SWITCH (5, FIGURE 2-13) electrical leads.
- e. Set multimeter for ohms and check switch for continuity Refer to Electrical Schematic FO-1 (S-1 Circuit Schedule) to determine circuits made to corresponding switch positions.
- f. Check continuity until all four positions have been checked.
- g. If open circuit is noted in any switch position, switch is unserviceable and must be replaced.
- h. Connect electrical leads to MASTER SWITCH (5) and remove tags.
- i. Raise and secure control panel.
- j. Connect negative battery cable and close battery access door.

2-32-4 Installation.

- a. Connect electrical leads to MASTER SWITCH (5, FIGURE 2-13) and remove tags.
- b. Insert MASTER SWITCH (5) into control panel.
- c. Install screws (4) and nuts (3).
- d. Install knob (2) and tighten setscrew (1).

- e. Raise and secure control panel.
- f. Connect negative battery cable. Close battery access door.

2-33 ETHER SWITCH.

2-33-1 Inspection.

- a. Shut down generator set.
- b. Inspect switch for loose connections and mounting, and other damage.

2-33-2 Removal.

- a. Shut down generator set.
- b. Open battery access door and disconnect negative battery cable.
- c. Release control panel by turning two fasteners and lower control panel slowly.
- d. Tag and disconnect ETHER switch (8, FIGURE 2-13) electrical leads.
- e. Remove nut (6) and washer (7).
- f. Remove ETHER switch (8) from control panel and remove tab washer (9).

2-33-3 Testing.

- a. Shut down generator set.
- b. Open battery access door and disconnect negative battery cable.
- c. Release control panel by turning two fasteners and lower control panel slowly.
- d. Tag and disconnect ETHER switch (8, FIGURE 2-13) electrical leads.
- e. Set multimeter for ohms and connect across ETHER switch terminals. Multimeter should indicate open circuit.
- f. Hold ETHER switch in ON position. Multimeter should indicate continuity.
- g. Replace ETHER switch if indications are not as above.
- h. Connect electrical leads to ETHER switch (8) and remove tags.
- i. Raise and secure control panel.
- j. Connect negative battery cable and close battery access door.

2-33-4 Installation.

- a. Install tab washer (9, FIGURE 2-13) and insert ETHER switch (8) into control panel.
- b. Install washer (7) and nut (6).
- c. Connect electrical leads and remove tags.
- d. Raise and secure control panel.
- e. Connect negative battery cable. Close battery access door.

2-34 VOLTAGE ADJUST POTENTIOMETER.

2-34-1 Inspection.

- a. Shut down generator set.
- b. Inspect potentiometer for loose connections and mounting, and other damage.

2-34-2 Removal.

- a. Shut down generator set.
- b. Open battery access door and disconnect negative battery cable.
- c. Release control panel by turning two fasteners and lower control panel slowly.
- d. Tag and disconnect VOLTAGE adjust potentiometer (14, FIGURE 2-13) electrical leads using soldering gun. Remove shrinkable tubing.
- e. Remove setscrews (10) and knob (11).
- f. Remove nut (12) and washer (13).
- g. Remove VOLTAGE adjust potentiometer (14) from control panel.

2-34-3 Testing.

- a. Remove VOLTAGE adjust potentiometer, paragraph 2-34-2.
- b. Set multimeter for ohms and connect across two outer terminals of potentiometer. Indication shall be:
10,000 ohms (Part number RV4NAYSD103 A installed).
20,000 ohms (Part number RV4NAYSD203A installed).
- c. Rotate potentiometer shaft counterclockwise as far as it will go.
- d. Connect multimeter between center terminal and either outer terminal.
- e. Slowly, at an even rate, rotate potentiometer shaft clockwise as far as it will go while observing multimeter.
- f. Multimeter indication shall increase, at an even rate, as follows:
0 to 10,000 ohms (Part number RV4NAYSD103A installed).
0 to 20,000 ohms (Part number RV4NAYSD203A installed).
- g. If multimeter indication changes erratically or is not at maximum ohms when rotation is complete, the potentiometer is defective and must be replaced.
- h. Install VOLTAGE adjust potentiometer, paragraph 2-34-4.

2-34-4 Installation.

- a. Insert VOLTAGE adjust potentiometer (14, FIGURE 2-13) into control panel.
- b. Install washer (13) and nut (12).
- c. Install knob (11s) and setscrews (10).
- d. Install new shrinkable tubing and connect electrical leads using soldering gun. Remove tags.
- e. Raise and secure control panel.

- f. Connect negative battery cable. Close battery access door.

2-35 FREQUENCY ADJUST POTENTIOMETER.

2-35-1 Inspection.

- a. Shut down generator set.
- b. Inspect potentiometer for loose connections and mounting, and other damage.

2-35-2 Removal.

- a. Shut down generator set.
- b. Open battery access door and disconnect negative battery cable.
- c. Release control panel by turning two fasteners and lower control panel slowly.
- d. Tag and disconnect FREQUENCY adjust potentiometer (19, FIGURE 2-13) electrical leads using soldering gun. Remove shrinkable tubing.
- e. Remove setscrews (15) and knob (16).
- f. Remove nut (17) and washer (18).
- g. Remove FREQUENCY adjust potentiometer (19) from control panel.

2-35-3 Testing.

- a. Remove FREQUENCY adjust potentiometer, paragraph 2-35-2.
- b. Set multimeter for ohms and connect across outer terminals of potentiometer. Multimeter should indicate between 4500 and 5500 ohms resistance.
- c. Rotate potentiometer shaft counterclockwise as far as it will go.
- d. Connect multimeter between center terminal and either outer terminal. Multimeter should indicate zero ohms resistance.
- e. Slowly, at an even rate, rotate the potentiometer shaft clockwise as far as it will go. Multimeter should increase at an even rate from 0 to 5000 ohms.
- f. If multimeter indication changes erratically or is not between 4500 and 5500 ohms when the rotation is completed, the potentiometer is defective and must be replaced.
- g. Install FREQUENCY adjust potentiometer, paragraph 2-35-4.

2-35-4 Installation.

- a. Insert FREQUENCY adjust potentiometer(19, FIGURE 2-13) into control panel.
- b. Install washer (18) and nut (17).
- c. Install knob (16) and setscrews (15).
- d. Install new shrinkable tubing, solder leads, and remove tags.
- e. Raise and secure control panel.
- f. Connect negative battery cable. Close battery access door.

2-360 BATTLE SHORT SWITCH.

2-36-1 Inspection.

- a. Shut down generator set.
- b. Inspect switch for loose connections and mounting, and other damage.

2-36-2 Testing.

- a. Shut down generator set.
- b. Open battery access door and disconnect negative battery cable.
- c. Release control panel by turning two fasteners and lower control panel slowly.
- d. Tag and disconnect BATTLE SHORT switch (23, FIGURE 2-13) electrical leads.
- e. Place switch in ON position.

NOTE

Refer to Wiring Diagram FO-2 for terminal positions.

- f. Set multimeter for ohms and check for continuity between terminals 2 and 3, 5 and 6, 8 and 9, and 11 and 12.
- g.** Place switch in OFF position.
- h.** Check for continuity between terminals 1 and 2, 4 and 5, 7 and 8, and 10 and 11.
- i. Replace switch if any open circuit is indicated.
- j. Connect electrical leads to switch (23) and remove tags.
- k. Raise and secure control panel.
- l. Connect negative battery cable and close battery access door.

2-36-3 Removal.

- a. Shut down generator set.
- b. Open battery access door and disconnect negative battery cable.
- c. Release control panel by turning two fasteners and lower control panel slowly.
- d. Tag and disconnect BATTLE SHORT switch (23, FIGURE 2-13) electrical leads.
- e. Remove nut (20), washer (21), and protective cover (22).
- f. Remove BATTLE SHORT switch (23) from control panel and tab washer (24) from switch stem.

2-36-4 Installation.

- a. Install tab washer (24, FIGURE 2-13) and insert BATTLE SHORT switch (23) into control panel.
- b. Install protective cover (22), washer (21), and nut (20).
- c. Connect electrical leads and remove tags.
- d. Raise and secure control panel.
- e. Connect negative battery cable. Close battery access door.

2-37 AC CIRCUIT INTERRUPTER SWITCH.

2-37-1 Inspection.

- a. Shutdown generator set.
- b. Inspect switch for loose connections and mounting, and other damage.

2-37-2 Testing.

- a. Shutdown generator set.
- b. Open battery access door and disconnect negative battery cable.
- c. Release control panel by turning two fasteners and lower control panel slowly.
- d. Tag and disconnect AC CIRCUIT INTERRUPTER switch (27, FIGURE 2-13) electrical leads.

NOTE

Refer to Wiring Diagram FO-2 for terminal positions.

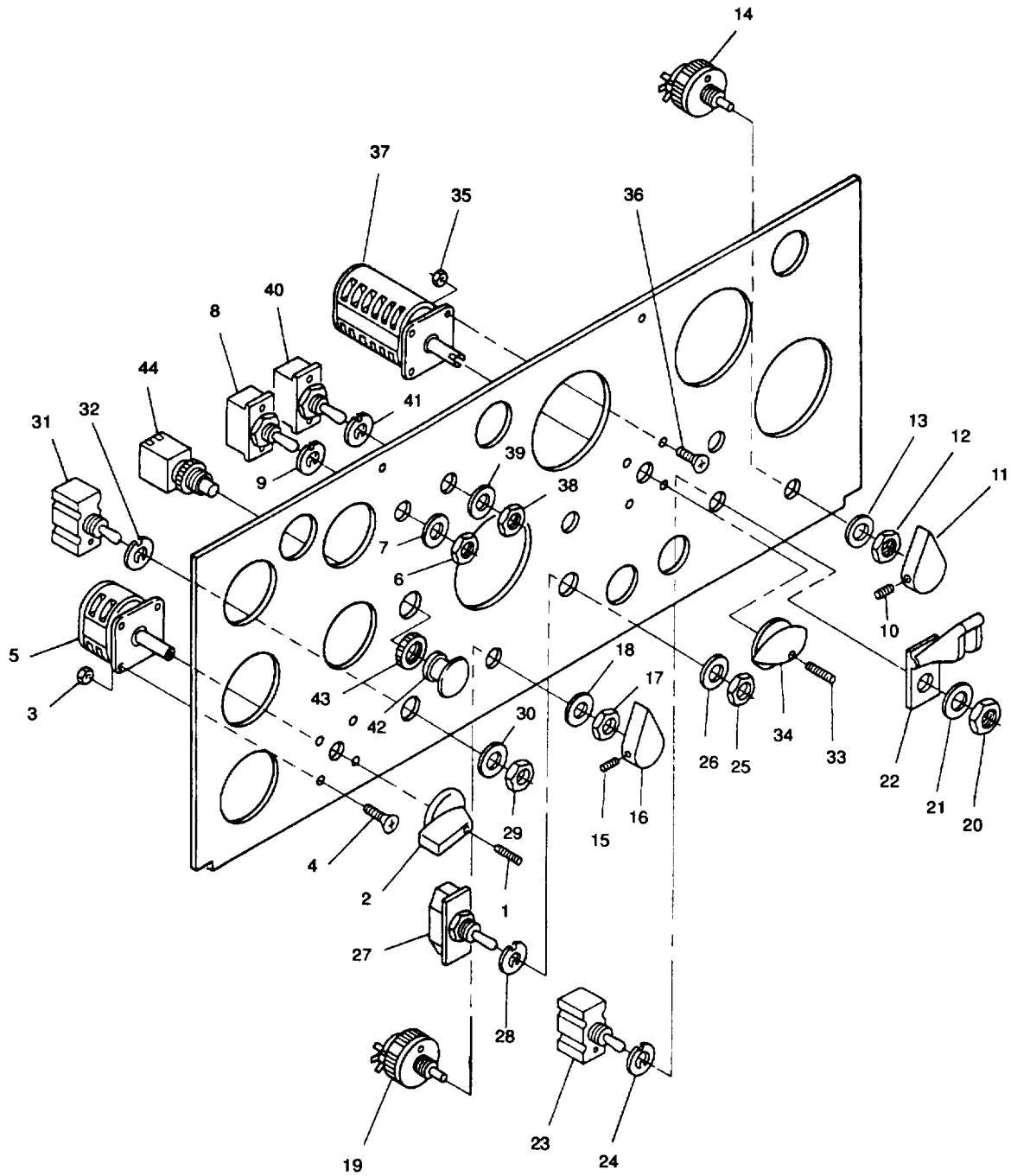

FIGURE 2-13. Control Panel Switches

- e. Set multimeter for ohms and check for continuity between terminals 5 and 4, and terminals 2 and 3.
- f. Check for open circuits between terminals 5 and 6, and terminals 1 and 2.
- g. Place and hold AC CIRCUIT INTERRUPTER switch in CLOSED position.
- h. Check for continuity between terminals 5 and 6, and terminals 2 and 3.
- i. Check for open circuits between terminals 5 and 4, and terminals 2 and 1.
- j. Place and hold AC CIRCUIT INTERRUPTER switch in OPEN position.
- k. Check for continuity between terminals 5 and 4, and terminals 1 and 2.
- l. Check for open circuits between terminals 5 and 6, and terminals 3 and 1.
- m. Replace switch if any continuity check is other than indicated above.
- n. Connect electrical leads to switch (27) and remove tags.
- o. Raise and secure control panel.
- p. Connect negative battery cable and close battery access door.

2-37-3 Removal.

- a. Shut down generator set.
- b. Open battery access door and disconnect negative battery cable.
- c. Release control panel by turning two fasteners and lower control panel slowly.
- d. Tag and disconnect AC CIRCUIT INTERRUPTER switch (27, FIGURE 2-13) electrical leads.
- e. Remove nut (25) and washer (26).
- f. Remove AC CIRCUIT INTERRUPTER switch (27) from control panel and tab washer (28) from switch stem.

2-37-4 Installation

- a. Install tab washer (28, FIGURE 2-13) and insert AC CIRCUIT INTERRUPTER switch (27) into control panel.
- b. Install washer (26) and nut (25).
- c. Connect electrical leads and remove tags.
- d. Raise and secure control panel.
- e. Connect negative battery cable. Close battery access door.

2-38 PARALLEL-UNIT SWITCH.

2-38-1 Inspection.

- a. Shutdown generator set.
- b. Inspect switch for loose connections and mounting, and other damage.

2-38-2 Removal.

- a. Shutdown generator set.

- b. Open battery access door and disconnect negative battery cable.
- c. Release control panel by turning two fasteners and lower control panel slowly,
- d. Tag and disconnect PARALLEL-UNIT switch (31, FIGURE 2-13) electrical leads,
- e. Remove nut (29) end washer (30).
- f. Remove PARALLEL-UNIT switch (31) from control panel and tab washer (32) from switch stem.

2-38-3 Testing.

- a. Shut down generator set.
- b. Open battery access door and disconnect negative battery cable.
- c. Release control panel by turning two fasteners and lower control panel slowly.
- d. Tag and disconnect PARALLEL-UNIT switch (31, FIGURE 2-13) electrical leads.

NOTE

Refer to Wiring Diagram FO-2 for terminal positions.

- e. Place switch in PARALLEL position.
- f. Set multimeter for ohms and check for continuity between terminals 1 and 2, 4 and 5, 7 and 8, and 10 and 11.
- g. Place switch in UNIT position.
- h. Check for continuity between terminals: 2 and 3, 5 and 6, 8 and 9, and 11 and 12.
- i. Replace switch if any open circuit is indicated.
- j. Connect electrical leads to switch (31) and remove tags.
- k. Raise and secure control panel.
- l. Connect negative battery cable and close battery access door.

2-38-4 Installation.

- a. Install tab washer (32, FIGURE 2-13) and insert PARALLEL-UNIT switch (31) into control panel.
- b. Install washer (30) and nut (29).
- c. Connect electrical leads and remove tags.
- d. Raise and secure control panel.
- e. Connect negative battery cable. Close battery access door.

2-39 AM-VM TRANSFER SWITCH.

2-39-1 Inspection.

- a. Shutdown generator set.
- b. Inspect switch for loose connections and mounting, and other damage.

2-39-2 Removal.

- a. Shut down generator set.
- b. Open battery access door and disconnect negative battery cable.
- c. Release control panel by turning two fasteners and lower control panel slowly.
- d. Remove setscrew (33, FIGURE 2-13) and knob (34).
- e. Remove nuts (35) and screws (36).
- f. Remove AM-VM transfer switch (37) from control panel.
- g. Tag and disconnect AM-VM transfer switch (37) electrical leads.

2-39-3 Testing.

- a. Shut down generator set.
- b. Remove AM-VM transfer switch, paragraph 2-39-2.
- c. Set multimeter for ohms and check AM-VM transfer switch for continuity. Refer to Electrical Schematic FO-1 (S-6 Circuit Schedule) to determine circuits made to corresponding switch positions.
- d. Check continuity in all six switch positions.
- e. If open circuit is noted in any switch position, AM-VM transfer switch is unserviceable and must be replaced.
- f. Install AM-VM transfer switch, paragraph 2-39-4.

2-39-4 Installation

- a. Connect electrical leads to AM-VM transfer switch (37, FIGURE 2-13) and remove tags.
- b. Insert AM-VM transfer switch (37) into control panel.
- c. Install screws (36) and nuts (35).
- d. Install knob (34) and setscrew (33).
- e. Raise and secure control panel.
- f. Connect negative battery cable. Close battery access door.

2-40 PANEL LIGHTS SWITCH

2-40-1 Inspection.

- a. Shut down generator set.
- b. Inspect switch for loose connections and mounting, and other damage.

2-40-2 Removal.

- a. Shutdown generator set.
- b. Open battery access door and disconnect negative battery cable.
- c. Release control panel by turning two fasteners and lower control panel slowly.
- d. Tag and disconnect PANEL LIGHTS switch (40, FIGURE 2-13) electrical leads.
- e. Remove nut (38) and washer (39).

- f. Remove PANEL LIGHTS switch (40) from control panel and tab washer (41) from switch stem.

2-40-3 Testing.

- a. Shut down generator set.
- b. Open battery access door and disconnect negative battery cable.
- c. Release control panel by turning two fasteners and lower control panel slowly.
- d. Tag and disconnect PANEL LIGHTS switch (40, FIGURE 2-13) electrical leads.
- e. Set multimeter for ohms and connect across switch terminals.
- f. Place switch in ON position. Multimeter should indicate continuity.
- g. Place switch in OFF position. Multimeter should indicate open circuit.
- h. Replace PANEL LIGHTS switch if readings are not as above.
- i. Connect electrical leads to switch (40) and remove tags.
- j. Raise and secure control panel.
- k. Connect negative battery cable and close battery access door.

2-40-4 Installation.

- a. Install tab washer (41, FIGURE 2-13) and insert PANEL LIGHTS switch (40) into control panel.
- b. Install washer (39) and nut (36).
- c. Install electrical leads and remove tags.
- d. Raise and secure control panel.
- e. Connect negative battery cable. Close battery access door.

2-41 EMERGENCY STOP SWITCH.

2-41-1 Inspection.

- a. Shut down generator set.
- b. Inspect switch for loose connections and mounting, and other damage.

2-41-2 Removal.

- a. Shut down generator set.
- b. Open battery access door and disconnect negative battery cable.
- c. Release control panel by turning two fasteners and lower control panel slowly.
- d. Tag and disconnect EMERGENCY STOP switch (44, FIGURE 2-13) electrical leads.
- e. Remove knob (42) and nut (43).
- f. Remove EMERGENCY STOP switch (44) from control panel.

2-41-3 Testing.

- a. Shut down generator set.
- b. Open battery access door and disconnect negative battery cable.
- c. Release control panel by turning two fasteners and lower control panel slowly.
- d. Tag and disconnect EMERGENCY STOP switch (44, FIGURE 2-13) electrical leads.
- e. With Switch in normal (OUT) position, set multimeter for ohms and check circuit between switch terminals. If no continuity is indicated, EMERGENCY STOP switch is defective.
- f. Push EMERGENCY STOP switch to the in position.
- g. Check for continuity between switch terminals. Replace switch if continuity is indicated.
- h. Connect electrical leads to switch (44) and remove tags.
- i. Raise and secure control panel.
- j. Connect negative battery cable and close battery access door.

2-41-4 Installation.

- a. Insert EMERGENCY STOP switch (44, FIGURE 2-13) into control panel.
- b. Install nut (43) and knob (42).
- c. Connect electrical leads and remove tags.
- d. Raise and secure control panel.
- e. Connect negative battery cable and close battery access door.

2-42 REACTIVE CURRENT ADJUST RHEOSTAT.

2-42-1 Inspection.

- a. Shut down generator set.
- b. Inspect rheostat for loose connections and mounting, and other damage.

2-42-2 Testing.

- a. Shut down generator set.
- b. Open battery access door and disconnect negative battery cable.
- c. Remove control box top panel, paragraph 2-15-1.
- d. Disconnect wires 143C from TB4 terminal 21, 142A from TB6 terminal 12, and 135B from TB5 terminal 4.
- e. Mark reading of REACTIVE CURRENT ADJUST rheostat to reposition at conclusion of testing steps.
- f. Set multimeter for ohms and connect to wires 135B and 142A. Multimeter reading should be between 4.5 and 5.5 ohms.
- g. Connect multimeter to wires 135B and 143C, and turn REACTIVE CURRENT ADJUST rheostat to full clockwise position. Multimeter reading should be approximately 0 ohms. Turn REACTIVE CURRENT ADJUST rheostat slowly to full counter clockwise position and observe multimeter. Multimeter reading should evenly increase to between 4.5 and 5.5 ohms.

- h. Connect multimeter to wires 142A and 143C, and turn REACTIVE CURRENT ADJUST rheostat to full clockwise position. Multimeter reading should be between 4.5 and 5.5 ohms. Turn REACTIVE CURRENT ADJUST rheostat slowly to full counter clockwise position and observe multimeter. Multimeter reading should evenly decrease to approximately 0 ohms.
- i. Replace REACTIVE CURRENT ADJUST rheostat if multimeter readings are other than above.
- j. Reposition REACTIVE CURRENT ADJUST rheostat as marked in step e.
- k. Connect electrical wires as tagged.
- l. Install control box top panel, paragraph 2-15-4.
- m. Connect negative battery cable and close battery access door.

2-42-3 Removal.

- a. Shut down generator set.
- b. Open battery access door and disconnect negative battery cable.
- c. Remove control box top panel, paragraph 2-15-1.
- d. Tag and disconnect REACTIVE CURRENT ADJUST rheostat (3, FIGURE 2-14) electrical leads by unsoldering and remove shrinkable tubing.
- e. Remove nuts (1) and (2), and rheostat (3).

2-42-4 Installation.

- a. Install rheostat (3, FIGURE 2-14) in mounting bracket.
- b. Install nuts (1) and (2).
- c. Install new shrinkable tubing, solder electrical leads, and remove tags.
- d. Install control box top panel, paragraph 2-15-4.
- e. Connect negative battery cable. Close battery access door.

2-43 LOAD SHARING ADJUST RHEOSTAT.

2-43-1 Inspection.

- a. Shut down generator set.
- b. Inspect rheostat for loose connections and mounting, and other damage.

2-43-2 Testing.

- a. Shut down generator set.
- b. Open battery access door and disconnect negative battery cable.
- c. Remove control box top panel, paragraph 2-15-1.
- d. Tag and disconnect wire 161 B from reverse power relay, terminal 2. Insulate end of wire.
- e. Disconnect wire 159A from governor control unit, terminal 11.
- f. Set multimeter for ohms and connect positive lead to wire 159A and negative lead of multimeter to terminal 12 of governor control unit. Record reading of rheostat.

- g. Turn LOAD SHARING ADJUST rheostat to full counter clockwise position. Multimeter reading should be between 4500 and 5500 ohms.
- h. Turn LOAD SHARING ADJUST rheostat to full clockwise position. Multimeter reading should be approximately 0 ohms.
- i. Replace LOAD SHARING ADJUST rheostat if multimeter readings are other than above.
- j. If readings are within tolerance, return rheostat to reading recorded in step f.
- k. Connect electrical wires as tagged.
- l. Install control box top panel, paragraph 2-15-4.
- m. Connect negative battery cable and close battery access door.

2-43-3 Removal.

- a. Shut down generator set.
- b. Open battery access door and disconnect negative battery cable.
- c. Remove control box top panel, paragraph 2-15-1.
- d. Tag and disconnect LOAD SHARING ADJUST rheostat (7, FIGURE 2-14) electrical leads.
- e. Remove nuts (4) and (5), lockwasher (6), and rheostat (7).

2-43-4 Installation.

- a. Install LOAD SHARING ADJUST rheostat (7, FIGURE 2-14) in mounting bracket.
- b. Install lockwasher (6) and nuts (5) and (4).
- c. Connect electrical leads and remove tags.
- d. Install control box top panel, paragraph 2-15-4.
- e. Connect negative battery cable. Close battery access door.

2-44 OVERSPEED RESET SWITCH.

2-44-1 Inspection.

- a. Shut down generator set.
- b. Inspect switch for loose connections and mounting, and other damage.

2-44-2 Testing.

- a. Shut down generator set.
- b. Open battery access door and disconnect negative battery cable.
- c. Remove control box top panel, paragraph 2-15-1.
- d. Tag and disconnect OVERSPEED RESET switch (10, FIGURE 2-14) electrical leads.
- e. Set multimeter for ohms and connect across switch terminals. Multimeter should indicate continuity.
- f. Position and hold switch in the up position. Multimeter should indicate open circuit.

- g. OVERSPEED RESET switch is defective and must be replaced, if indications are other than above.
- h. Connect electrical leads to switch (10) and remove tags.
- i. Install control box top panel, paragraph 2-15-4.
- j. Connect negative battery cable and close battery access door.

2-44-3 Removal.

- a. Shut down generator set.
- b. Open battery access door and disconnect negative battery cable.
- c. Remove control box top panel, paragraph 2-15-1.
- d. Tag and disconnect OVERSPEED RESET switch (10, FIGURE 2-14) electrical leads.
- e. Remove nut (8), lockwasher (9), and switch (10).

2-44-4 Installation.

- a. Install OVERSPEED RESET switch (10, FIGURE 2-14) in mounting bracket.
- b. Install lockwasher (9) and nut (8).
- c. Connect electrical leads and remove tags.
- d. Install control box top panel, paragraph 2-15-4.
- e. Connect negative battery cable. Close battery access door.

2-45 FREQUENCY SELECT SWITCH.

NOTE

Applicable to MEP-805A only.

2-45-1 Inspection..

- a. Shut down generator set.
- b. Inspect switch for loose connections and mounting, and other damage.

2-45-2 Testing.

- a. Shut down generator set.
- b. Open battery access door and disconnect negative battery cable.
- c. Remove control box top panel, paragraph 2-15-1.
- d. Tag and disconnect FREQUENCY SELECT switch (14, FIGURE 2-14) electrical leads.
- e. Set multimeter for ohms and connect across switch terminals.
- f. Place switch in the up (80 Hz) position. Multimeter should indicate continuity.
- g. Place switch in down (50 Hz) position. Multimeter should indicate continuity.
- h. FREQUENCY SELECT switch is defective and must be replaced, if indications are other than above.

- i. Connect electrical leads to switch (14) and remove tags.
- j. Install control box top panel, paragraph 2-15-4.
- k. Connect negative battery cable and close battery access door.

2-45-3 Removal.

- a. Shut down generator set.
- b. Open battery access door and disconnect negative battery cable.
- c. Remove control box top panel, paragraph 2-15-1.
- d. Tag and disconnect electrical leads from FREQUENCY SELECT switch (14, FIGURE 2-14).
- e. Tag and remove resistor (11) from FREQUENCY SELECT switch (14).
- f. Remove nut (12), lockwasher (13), and FREQUENCY SELECT switch (14).

2-45-4 Installation.

- a. Position FREQUENCY SELECT switch (14, FIGURE 2-14) in mounting bracket.
- b. Install lockwasher (13) and nut (12).
- c. Install resistor (11) on FREQUENCY SELECT switch (14) and remove tags.
- d. Connect electrical leads and remove tags.
- e. Install control box top panel, paragraph 2-15-4.
- f. Connect negative battery cable and close battery access door.

2-46 CONVENIENCE RECEPTACLE.

2-46-1 Inspection.

- a. Shut down generator set.
- b. Inspect CONVENIENCE RECEPTACLE for cracks, breaks, corrosion, bent terminals, or other indications of damage.
- c. Inspect cover for cracks, corrosion, or damaged springs.
- d. Replace defective parts.

2-46-2 Testing.

- a. Shut down generator set.
- b. Remove control box top panel, paragraph 2-15-1.
- c. Tag and disconnect CONVENIENCE RECEPTACLE (20, FIGURE 2-14) electrical leads.
- d. Set multimeter for ohms and check for continuity between upper side terminals and lower side terminals of each plug outlet.
- e. Replace CONVENIENCE RECEPTACLE if continuity is not indicated between terminals.
- f. Connect electrical leads to receptacle (20) and remove tags.

- g. Install control box top panel, paragraph 2-15-4.

2-46-3 Removal.

- a. Shut down generator set.
- b. Open battery access door and disconnect negative battery cable.
- c. Remove control box top panel, paragraph 2-15-1.
- d. Remove screws (15, FIGURE 2-14) and nuts (16).
- e. Remove CONVENIENCE RECEPTACLE cover (17).
- f. Remove machine screws (18), nuts (19), and CONVENIENCE RECEPTACLE (20).
- g. Tag and disconnect CONVENIENCE RECEPTACLE (20) electrical leads.

2-46-4 Installation.

- a. Connect electrical leads to CONVENIENCE RECEPTACLE (20, FIGURE 2-14) and remove tags.
- b. Install CONVENIENCE RECEPTACLE (20) into panel cutout with machine screws(18) and nuts (19).
- c. Install CONVENIENCE RECEPTACLE cover (17) with screws (15) and nuts (16).
- d. Install control box top panel, paragraph 2-15-4.
- e. Connect negative battery cable, Close battery access door.

2-47 GROUND FAULT CIRCUIT INTERRUPTER.

2-47-1 Inspection.

- a. Shut down generator set.
- b. Inspect GROUND FAULT CIRCUIT INTERRUPTER for cracks, corrosion, frayed wires, and other damage.

2-47-2 Testing.

- a. Start and operate generator set at rated voltage and frequency.
- b. Set multimeter for AC volts, press TEST button and check for zero voltage at the CONVENIENCE RECEPTACLE.
- c. Press RESET button and use multimeter to check for 120 VAC at the CONVENIENCE RECEPTACLE.
- d. Replace GROUND FAULT CIRCUIT INTERRUPTER if indications are other than above.

2-47-3 Removal.

- a. Shut down generator set.
- b. Open battery access door and disconnect negative battery cable.
- c. Remove control box top panel, paragraph 2-15-1.
- d. Tag and disconnect GROUND FAULT CIRCUIT INTERRUPTER (23, FIGURE 2-14) electrical leads from TB4 and K5, and CONVENIENCE RECEPTACLE (20).
- e. Remove screws (21) and nuts (22).

- f. Remove GROUND FAULT CIRCUIT INTERRUPTER (23) from malfunction indicator panel (27).

2-46-3.1. In-Line Fuse Installation.

NOTE

The following procedures applies to generator sets under contract number DAAK01-88-D-D082.

- a. Shut down generator set.
- b. Open left side engine access door and disconnect negative battery cable.
- c. Remove malfunction indicator panel screws (24, FIGURE 2-14), washers (25), and nuts (26). Lay malfunction indicator panel to the side.
- d. Cut black wire on load side of GROUND FAULT CIRCUIT INTERRUPTER (23).
- e. Strip wires on in-line fuse holder (2, FIGURE 2-13.1) and install butt splices (3) at each end. Connect ends of black wire to in-line fuse holder butt splices (3).
- f. Install fuse (1) in fuse holder (2).
- g. Secure excess wire to wiring harness using tie wrap.
- h. Install malfunction indicator panel (27, FIGURE 2-14), screws (24), washers (25), and nuts (26).
- i. Reconnect negative battery cable and close battery access door.

NOTE

When replacing GROUND FAULT CIRCUIT INTERRUPTER, use new GROUND FAULT CIRCUIT INTERRUPTER with integral circuit breaker. Refer to TM 9-6115-644-24P for new part number.

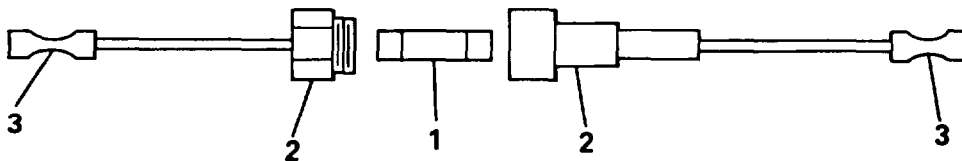

FIGURE 2-13.1. In-Line Fuse Installation

2-47-4 Installation.

- a. Install GROUND FAULT CIRCUIT INTERRUPTER (23, FIGURE 2-14) in malfunction indicator panel (27) with screws (21) and nuts (22).
- b. Connect electrical leads to TB4 and K5, CONVENIENCE RECEPTACLE (20), and remove tags.
- c. Install control box top panel, paragraph 2-15-4.
- d. Connect negative battery cable. Close battery access door.

2-48 MALFUNCTION INDICATOR PANEL

2-48-1 Inspection.

- a. Shut down generator set.
- b. Inspect malfunction indicator panel for broken indicator lights, cracked housing, corrosion, and other damage.

2-48-2 Testing.

- a. Depress TEST/RESET button and check that all indicators are lit.
- b. Replace malfunction indicator panel if one or more indicators do not light.

2-48-3 Removal.

- a. Shut off generator set.
- b. Open battery access door and disconnect negative battery cable.
- c. Release control panel by turning two fasteners and lower control panel slowly.
- d. Remove GROUND FAULT CIRCUIT INTERRUPTER, paragraph 2-47-3 (Do not disconnect electrical leads).
- e. Disconnect multi-pin connector at rear of malfunction indicator panel (27, FIGURE 2-14).
- f. Remove bolts (24), washers (25), and nuts (26).
- g. Remove malfunction indicator panel (27) from control panel.

2-48-4 Installation.

- a. Install malfunction indicator panel (27, FIGURE 2-14) in control panel with bolts (24), washers (25), and nuts (26).
- b. Install multi-pin connector at rear of panel.
- c. Install GROUND FAULT CIRCUIT INTERRUPTER paragraph 2-47-4.
- d. Raise and secure control panel.
- e. Connect negative battery cable. Close battery access door.

2-49 BATTERY CHARGER FUSE

2-49-1 Removal.

- a. Shut down generator set.

- b. Open battery access door and disconnect negative battery cable.
- c. Release control panel by turning two fasteners and lower control panel slowly.
- d. Remove cap (28, FIGURE 2-14) and fuse (29) from fuse holder (32).
- e. Tag and unsolder electrical leads from fuse holder (32).
- f. Remove nut (30), lockwasher (31), and fuse holder (32).

2-49-2 Inspection.

- a. Shut down generator set.
- b. Inspect for blown fuse.
- c. Inspect fuse, fuse holder, and cap for cracks, corrosion, and obvious damage.
- d. Replace defective parts.

2-49-3 Installation.

- a. Install fuse holder (32, FIGURE 2-14) and secure with lockwasher (31) and nut (38).
- b. Solder electrical leads to fuse holder (32) and remove tags.
- c. Install fuse (29) and cap (28).
- d. Raise and secure control panel.
- e. Connect negative battery cable. Close battery access door.

2-50 DC CONTROL POWER CIRCUIT BREAKER.

2-50-1 Inspection.

- a. Shut down generator set.
- b. Inspect circuit breaker for loose connections and mounting, cracked housing, and other damage.

2-50-2 Testing.

- a. Shut down generator set.
- b. Open battery access door and disconnect negative battery cable.
- c. Release control panel by turning two fasteners and lower control panel slowly.
- d. Tag and disconnect DC CONTROL POWER circuit breaker (35, FIGURE 2-14) electrical leads.
- e. Place circuit breaker in OPEN position.
- f. Set multimeter for ohms and connect across circuit breaker terminals. Multimeter should indicate open circuit.
- g. Place circuit breaker in the CLOSED position. Multimeter should indicate continuity.
- h. Replace circuit breaker if indications are not as above.
- i. Connect electrical leads to circuit breaker (35) and remove tags.
- j. Raise and secure control panel.

- k. Connect negative battery cable and close battery access door.

2-50-3 Removal.

- a. Shutdown generator set.
- b. Open battery access door and disconnect negative battery cable.
- c. Release control panel by turning two fasteners and lower control panel slowly.
- d. Remove nut (33, FIGURE 2-4) and flatwasher (34).
- e. Remove DC CONTROL POWER circuit breaker (35) from mounting bracket.
- f. Tag and disconnect DC CONTROL POWER circuit breaker (35) electrical leads.

2-50-4 Installation.

- a. Connect electrical leads and remove tags.
- b. Insert DC CONTROL POWER circuit breaker (35, FIGURE 2-14) into mounting bracket.
- c. Install flatwasher (34) and nut (33).
- d. Raise and secure control panel.

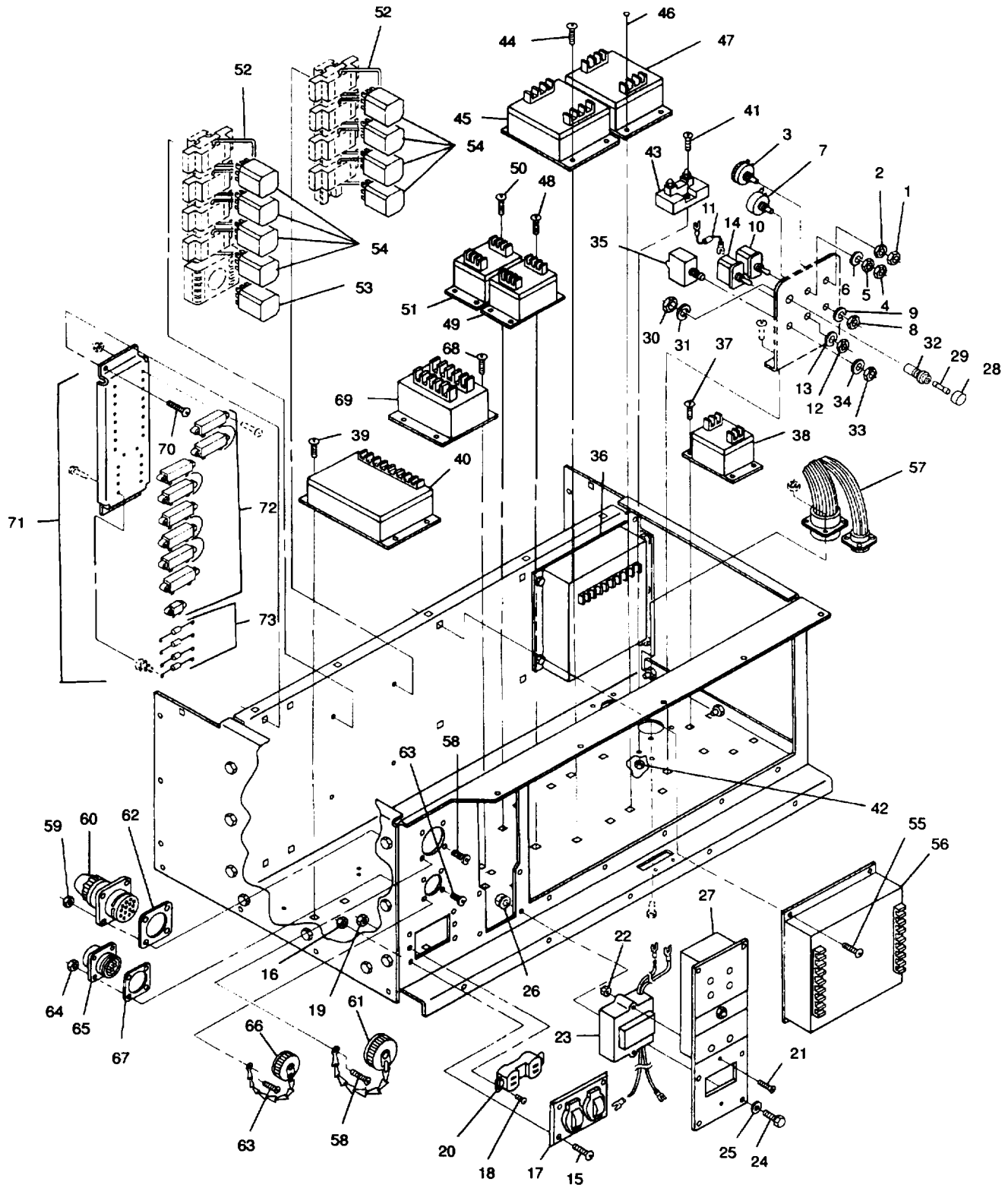

FIGURE 2-14. Control Box Components

- e. Connect negative battery cable. Close battery access door.

2-51 AC VOLTAGE REGULATOR.

Inspect AC voltage regulator (36, FIGURE 2-14) for cracked case, broken wires, security, and other damage.

2-52 FREQUENCY TRANSDUCER.

2-52-1 Inspection.

- a. Shut down generator set.
- b. Inspect transducer for cracked casing, burned or broken terminals, and other damage.

2-52-2 Testing (MEP 805A).

- a. Shut down generator set.
- b. Open battery access door and disconnect negative battery cable.
- c. Remove control box top panel, paragraph 2-15-1.
- d. Release control panel by turning two fasteners and lower control panel slowly.
- e. Disconnect wire 181 A from positive (+) terminal of FREQUENCY meter (HERTZ).
- f. Set multimeter for DC milliamperes (0 to 2 Ma range) and connect positive lead to disconnected wire 181 A, and negative lead to vacant terminal of FREQUENCY meter (HERTZ).
- g. Move FREQUENCY SELECT switch to 60 Hz position.
- h. Connect negative battery cable.
- i. Start generator set and adjust frequency to 60 Hz.
- j. Multimeter indication should be between 0.781 and 0.923 DC amps.
- k. Adjust frequency to 62 Hz and multimeter indication should be between 0.875 and 1.125 DC amps.
- l. Move FREQUENCY SELECT switch to 50 Hz position.
- m. Adjust frequency to 50 Hz and multimeter indication should be between 0.071 and 0.213 CD amps.
- n. Adjust frequency to 52 Hz and multimeter indication should be between 0.213 and 0.284 DC amps.
- o. Shut down generator set.
- p. Replace frequency transducer if readings are other than above.
- q. If no repair is needed, remove multimeter and connect wire 181A to positive (+) terminal of FREQUENCY meter (HERTZ).
- r. Raise and secure control panel.
- s. Install control box top panel, paragraph 2-15-4.

2-52-3 Testing (MEP 815A).

- a. Shut down generator set.
- b. Open battery access door and disconnect negative battery cable.

- c. Remove control box top panel, paragraph 2-15-1.
- d. Release control panel by turning two fasteners and lower control panel slowly.
- e. Disconnect wire 181A from positive terminal (+) of FREQUENCY meter (HERTZ).
- f. Set multimeter for DC milliamperes (0 to 2 Ma range) and connect positive lead to free end of wire 181A and connect negative lead to positive terminal (+) of FREQUENCY meter (HERTZ).
- g. Connect negative battery cable.
- h. Start and operate generator set at rated voltage and adjust frequency to 400 Hz.
- i. Multimeter indication should be between 0.229 and 0.271 Ma.
- j. Adjust frequency to 412 Hz. Multimeter indication should be between 0.479 and 0.521 Ma.
- k. Shut down generator set.
- L Replace frequency transducer if readings are other than above.
- m. If no repair is needed, remove multimeter and connect wire 181A to positive terminal (+) of FREQUENCY meter (HERTZ).
- n. Raise and secure control panel.
- o. Install control box top panel, paragraph 2-15-4.

2-52-4 Removal.

- a. Shut down generator set.
- b. Open battery access door and disconnect negative battery cable.
- c. Remove control box top panel, paragraph 2-15-1.
- d. Tag and disconnect frequency transducer (38, FIGURE 2-14) electrical leads.
- e. Remove screws (37) and frequency transducer (38).

2-52-5 Installation.

- a. Install frequency transducer (38, FIGURE 2-14) with screws (37).
- b. Connect all electrical leads and remove tags.
- c. Install control box top panel, paragraph 2-15-4.
- d. Connect negative battery cable. Close battery access door.

2-53 KILOWATT TRANSDUCER.

2-53-1 Inspection.

- a. Shutdown generator set.
- b. Inspect transducer for cracked casing, burned or broken terminals, and other damage.

2-53-2 Testing.

- a. Start and operate generator set at rated voltage and frequency.

- b. Apply some load to generator set.
- c. Release control panel by turning two fasteners and lower control panel slowly.
- d. Set multimeter for AC volts and take readings between terminals V1 and N1, V2 and N2, and V3 and N3. Multimeter indication should be 120 VAC between each set of terminals.
- e. Take readings between terminals S1 and -, S2 and -, S3 and -, L1 and -, L2 and -, and L3 and -. Multimeter indication should be 0.1 to 3 VAC (reading will vary depending on amount of load applied to generator set).
- f. Change multimeter setting to DC millivolts and take reading between terminals + and -. Multimeter indication should be 0.1 to 50 mv (dependent on amount of load applied to generator set).
- g. Shut down generator set.
- h. Replace kilowatt transducer if multimeter indications are within ranges stated in steps d and e, but not within range stated in step f.
- i. If no repair is needed, raise and secure control panel.

2-53-3 Removal.

- a. Shut down generator set.
- b. Open battery access door and disconnect negative battery cable.
- c. Remove control box top panel, paragraph 2-15-1.
- d. Tag and disconnect kilowatt transducer (40, FIGURE 2-14) electrical leads.
- e. Remove screws (39) and kilowatt transducer (40).

2-53-4 Installation.

- a. Install kilowatt transducer (40, FIGURE 2-14) with screws (39).
- b. Connect electrical leads and remove tags.
- c. Install control box top panel, paragraph 2-15-4.
- d. Connect negative battery cable. Close battery access door.

2-54 SHUNT

2-54-1 Inspection.

- a. Shut down generator set.
- b. Inspect shunt for cracked casing, burned or broken terminals, and other damage.

2-54-2 Testing.

- a. Shut down generator set.
- b. Remove control box top panel, paragraph 2-15-1.
- c. Open battery access door and disconnect negative battery cable.
- d. Tag and disconnect shunt (43, FIGURE 2-14) electrical leads.
- e. Set multimeter for ohms and connect to shunt terminals 1 and 4. Multimeter should indicate less than 0.5 ohms.

- f. Replace shunt if multimeter indication is greater than above.
- g. If no repair is needed, connect electrical leads to shunt (43) and remove tags.
- h. Install control box top panel, paragraph 2-15-4.
- i. Connect negative battery cable and close battery access door.

2-54-3 Removal.

- a. Shut down generator set.
- b. Open battery access door and disconnect negative battery cable.
- c. Remove control box top panel, paragraph 2-15-1.
- d. Tag and disconnect shunt (43, FIGURE 2-14) electrical leads.
- e. Remove control box assembly, paragraph 2-19-2.
- f. Remove screws (41), nuts (42) and shunt (43).

2-54-4

- a. Install shunt (43, FIGURE 2-14) and secure with screws (41) and nuts (42).
- b. Install control box assembly, paragraph 2-19-4.
- c. Connect all electrical leads and remove tags.
- d. Install control box top panel, paragraph 2-15-4.
- e. Connect negative battery cable. Close battery access door.

2-55 OVER/UNDER VOLTAGE RELAY.

2-55-1 Inspection.

- a. Shutdown generator set.
- b. Inspect relay for cracked casing, burned or broken terminals, and other damage.

2-55-2 Testing.

- a. Shutdown generator set.
- b. Open battery access door and disconnect negative battery cable.
- c. Release control panel by turning two fasteners and lower control panel slowly.

CAUTION

The following procedure disables voltage regulator and allows generator to reach an overvoltage condition. Do not allow generator set to operate for an extended period of time in an extreme overvoltage condition,

- d. Disconnect wire 137A from AC voltage regulator, terminal 5, and insulate wire end.
- e. Connect negative battery cable.

- f. Start generator set. As generator accelerates to rated speed, it should instantly shutdown and the OVERVOLTAGE lamp on malfunction indicator panel should light. If this does not occur immediately shutdown generator set.
- g. Reconnect wire 137A and disconnect wire 141 A from AC voltage regulator, terminal 1. Insulate wire end.
- h. Start generator set. As generator accelerates to rated speed, the UNDER VOLTAGE lamp on malfunction indicator should light. Move AC CIRCUIT INTERRUPTER switch to CLOSED position. AC circuit interrupter relay should not dose.
- i. Shut down generator set.
- j. Replace over/under voltage relay if generator set does not operate as above.
- k. If no repair is needed, reconnect wire 141A at AC voltage regulator.
- l. Raise and secure control panel.

2-55-3 Removal.

- a. Shut down generator set.
- b. Open battery access door and disconnect negative battery cable.
- c. Remove control box top panel, paragraph 2-15-1.
- d. Tag and disconnect over/under voltage relay (45, FIGURE 2-14) electrical leads.
- e. Remove screws (44) and over/under voltage relay (45).

2-55-4 Installation.

- a. Install over/under voltage relay (45, FIGURE 2-14) with screws (44).
- b. connect electrical leads and remove tags.
- c. Install control box top panel, paragraph 2-15-4.
- d. Connect negative battery cable. Close battery access door.

2-56 SHORT CIRCUIT/OVERLOAD RELAY.

2-56-1 Inspection.

- a. Shut down generator set.
- b. Inspect relay for cracked casing, burned or broken terminals, and other damage.

2-56-2 Testing.

CAUTION

Make sure battery cable is disconnected prior to removing wires. Failure to observe this caution could result in equipment damage.

- a. Tag and remove all wires from terminals 5 through 12.
- b. Set multimeter for ohms and check for open circuits between terminals 5 and 6, 9 and 10. Check for dosed circuits between terminals 7 and 8, 11 and 12. Replace any relay which fails the above still exists, notify next high level of maintenance.

- c. If no repair is needed reconnect wires as tagged..

2-56-3 Removal.

- a. Shut down generator set.
- b. Open battery access door and disconnect negative battery cable.
- c. Release control panel by turning two fasteners and lower control panel slowly.
- d. Tag and disconnect short circuit/overload relay (47, FIGURE 2-14) electrical leads.
- e. Remove screws (46) and short circuit/overload relay (47).

2-56-4 Installation.

- a. Install short circuit/overload relay (47, FIGURE 2-14) with screws (46).
- b. Connect electrical leads and remove tags.
- c. Raise and secure control panel.
- d. Connect negative battery cable. Close battery access door.

2-57 PERMISSIVE PARALLELING RELAY.

2-57-1 Inspection.

- a. Shut down generator set.
- b. Inspect relay for cracked casing, burned or broken terminals, and other damage.

2-57-2 Testing.

- a. Shut down generator set.
- b. Open battery access door and disconnect negative battery cable.
- c. Release control panel by turning two fasteners and lower control panel slowly.
- d. Disconnect and insulate wires 102D from terminal 1, and 196A and 196B from terminal 2 of permissive paralleling relay.
- e. Mark a 10,000 ohm potentiometer as follows:
 - Center terminal = C
 - Two outside terminals = L and R
- f. Set up a test circuit as shown in FIGURE 2-15. Connect 120 VAC source (can be obtained from convenience receptacle) to terminals L and R of potentiometer. Connect a wire from terminal C of potentiometer to terminal 1 of permissive paralleling relay. Connect a second wire from terminal R of potentiometer to terminal 2 of permissive paralleling relay. Set multimeter for AC volts and connect to terminals 1 and 2 of permissive paralleling relay.
- g. Adjust 10,000 ohm potentiometer to full counterclockwise position.
- h. Connect negative battery cable.
- i. Start and operate generator set at rated frequency and voltage. Multimeter indication should be 0 volts.

- j. Move AC CIRCUIT INTERRUPTER switch to CLOSED position and AC circuit interrupter relay should dose. Move AC CIRCUIT INTERRUPTER switch to OPEN position and AC circuit interrupter relay should open. Observe AC CIRCUIT INTERRUPTER light for actuation of relay.
- k. Adjust 10,000 ohm potentiometer clockwise until multimeter indicates 10 VAC.

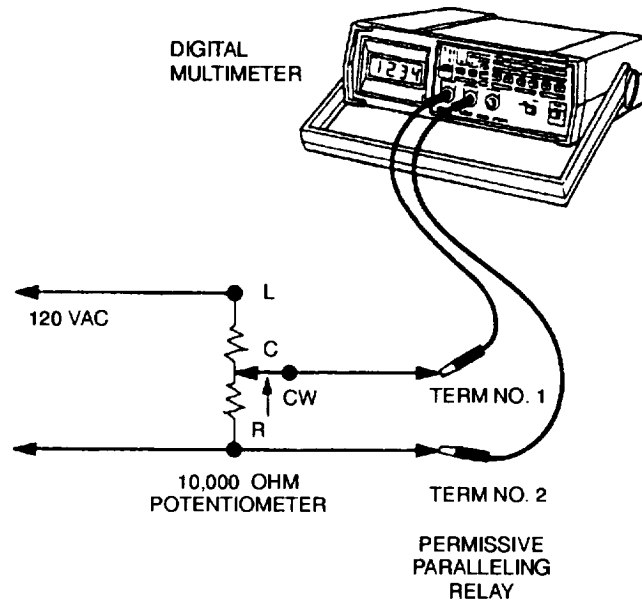

FIGURE 2-15. Permissive Paralleling Relay Test Set-up

- l. Move AC CIRCUIT INTERRUPTER switch to CLOSED position. The AC circuit interrupter relay should not dose (AC CIRCUIT INTERRUPTER light should remain dark).
- m. Shut down generator set.
- n. Disconnect negative battery cable.
- o. Replace permissive paralleling relay if operation is not as above.
- p. If no repair is needed, remove multimeter and test circuit wires. Reconnect wires 102D, 196A and 196B to permissive paralleling relay.
- q. Raise and secure control panel.
- r. Connect negative battery cable and close battery access door.

2-57-3 Removal.

- a. Shut down generator set.
- b. Open battery access door and disconnect negative battery cable.
- c. Release control panel by turning two fasteners and lower control panel slowly.
- d. Tag and disconnect permissive paralleling relay (49, FIGURE 2-14) electrical leads.
- e. Remove screws (46) and permissive paralleling relay (49).

2-57-4

- a. Install permissive paralleling relay (49, FIGURE 2-14) with screws (46).

- b. Connect all electrical leads and remove tags.
- c. Raise and secure control panel.
- d. Connect negative battery cable. Close battery access door.

2-58 REVERSE POWER RELAY.

2-58-1 Inspection.

- a. Shut down generator set.
- b. Inspect relay for cracked casing, burned or broken terminals, and other damage.

2-58-2 Testing.

- a. Shut down generator set.
- b. Open battery access door and disconnect negative battery cable.
- c. Release control panel by turning two fasteners and lower control panel slowly.
- d. Disconnect and insulate wires 158B and 158C from terminal 1, and 161A and 161 B from terminal 2 of reverse power relay.
- e. Mark a 5,000 ohm potentiometer as follows:

Center terminal = C

Two outside
terminals = L and R

CAUTION

Voltage polarity is very important to prevent damage to generator set.

- f. Set up a test circuit as shown in FIGURE 2-16. Connect 24 VDC source to terminals L and R of potentiometer. Connect a wire between terminal C of potentiometer and terminal 1 of reverse power relay. Connect a second wire between terminal R of potentiometer and terminal 2 of reverse power relay. Set multimeter for DC volts and connect positive lead of multimeter to terminal 1 and negative lead to terminal 2 of reverse power relay.
- g. Adjust 5,000 ohm potentiometer to full counterclockwise position. Multimeter should indicate 0 volts.

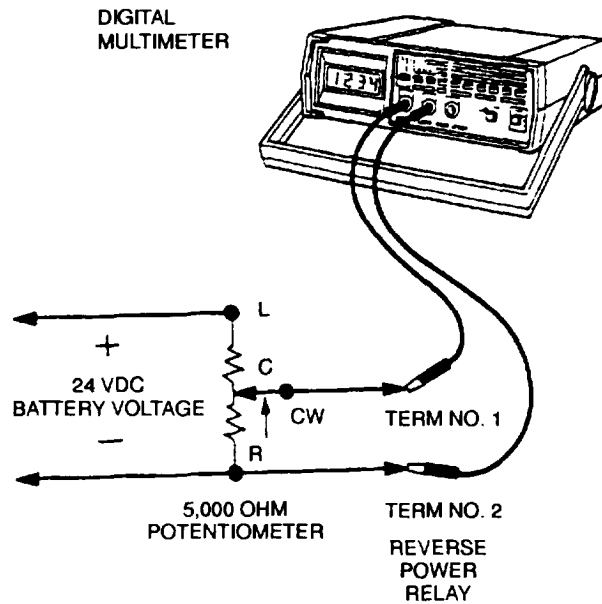

FIGURE 2-16. Reverse Power Relay Test Set-up

- h. Connect negative battery cable.
- i. Start and operate generator set at rated frequency and voltage.
- j. Move AC CIRCUIT INTERRUPTER switch to CLOSED position. AC CIRCUIT INTERRUPTER light should light.
- k. Adjust 5,000 ohm potentiometer clockwise and at the same time observe multimeter and AC CIRCUIT INTERRUPTER light. AC CIRCUIT INTERRUPTER light should go out at between 1.7 and 2.3 VDC indicating that AC circuit interrupter relay is open.
- L. Shut down generator set.
- m. Disconnect negative battery cable.
- n. Replace reverse power relay if operation is not as above.
- o. Remove multimeter and test circuit wires. Reconnect wires 158B, 158C, 161A and 161 B at reverse power relay.
- p. Raise and secure control panel.
- q. Connect negative battery cable and close battery access door.

2-58-3

- a. Shut down generator set.
- b. Open battery access door and disconnect negative battery cable.
- c. Release control panel by turning two fasteners and lower control panel slowly.
- d. Tag and disconnect reverse power relay (51, FIGURE 2-14) electrical leads.
- e. Remove screws (50) and reverse power relay (51).

2-58-4

- a. install reverse power relay (51, FIGURE 2-14) with screws (50).

- b. Connect electrical leads and remove tags.
- c. Raise and secure control panel.
- d. Connect negative battery cable. Close battery access door.

2-59 VOLTAGE SENSING RELAY.

2-59-1 Inspection.

- a. Shut down generator set.
- b. Inspect relay for cracks, loose mounting, and other damage.

2-59-2 Testing.

- a. Shut down generator set.
- b. Remove voltage sensing relay (K-11), paragraph 2-59-3.
- c. Set multimeter for ohms and check for open circuits between terminals 1 and 3, and terminals 8 and 6 of voltage sensing relay.
- d. Check for continuity between terminals 1 and 4, and terminals 8 and 5.
- e. Connect multimeter between terminals 2 and 7 of relay and check for between 1260 and 1890 ohms.
- f. Depress reset button and check for open circuits between terminals 1 and 4, and terminals 8 and 5.
- g. With reset button still depressed, check for continuity between terminals 1 and 3, and terminals 8 and 6.
- h. Replace voltage sensing relay if indications are not as above.
- i. If no repair is needed, install voltage sensing relay, paragraph 2-59-4.

2-59-3 Removal.

- a. Shut down generator set.
- b. Open battery access door and disconnect negative battery cable.
- c. Release control panel by turning two fasteners and lower control panel slowly.
- d. Release wire clip (52, FIGURE 2-14) and remove voltage sensing relay (K-11) (53) by gently pulling from socket.

2-59-4 Installation.

- a. Install voltage sensing relay (K-n) (53, FIGURE 2-14) in socket and secure by snapping wire dip (52) over relay.
- b. Raise and secure control panel.
- c. Connect negative battery cable and close battery access door.

2-60 Relays.

2-60-1 Inspection.

- a. Shutdown generator set.
- b. Inspect relays for cracks, loose mounting, and other damage.

2-60-2 Testing.

- a. Shut down generator set.
- b. Remove applicable relay, paragraph 2-60-3.
- c. Set multimeter for ohms and check for open circuits between terminals 7 and 4, 8 and 5, and 9 and 6. Check for dosed circuits between terminals 7 and 1, 8 and 2, and 9 and 3.
- d. Connect multimeter between terminals A and B, and check for between 427.5 and 522.5 ohms. .
- e. Apply battery voltage across terminals A and. Using multimeter, check for open circuits between terminals 7 and 1, 8 and 2, and 9 and 3. Check for dosed circuits between terminals 7 and 4, 8 and 5 and 9 and 6.
- f. If indications are other than above, relay is defective and must be replaced.
- g. If no repair is needed, install relay, paragraph 2-60-4.

2-60-3 Removal.

- a. Shut down generator set.
- b. Open battery access door and disconnect negative battery cable.
- c. Release control panel by turning two fasteners and lower control panel slowly.
- d. Locate suspected defective relay (54, FIGURE 2-14), release wire dip (52) and remove relay by gently pulling from socket.

2-60-4 Installation.

- a. Install relay (54, FIGURE 2-14) in socket and secure by snapping wire clip (52) over relay.
- b. Raise and secure control panel.
- c. Connect negative battery cable. Close battery access door.

2-61 GOVERNOR CONTROL UNIT.

2-61-1 Inspection.

- a. Shut down generator set.
- b. Inspect governor control unit for loose connections and mounting, and other damage.

2-61-2 Removal.

- a. Shut down generator set.
- b. Open battery access door and disconnect negative battery cable.
- c. Release control panel by turning two fasteners and lower control panel slowly.
- d. Tag and disconnect governor control unit (56, FIGURE 2-14) electrical leads.
- e. Remove screws (55) and governor control unit (56).

2-61-3 Installation.

- a. Install governor control unit (56, FIGURE 2-14) with screws (55).
- b. Connect electrical leads and remove tags.
- c. Raise and secure control panel.

- d. Connect negative battery cable. Close battery access door.

2-62 CONTROL BOX HARNESS.

2-62-1 Inspection.

- a. Shut down generator set.
- b. Inspect control box harness (57, FIGURE 2-14) wiring for breaks, damaged insulation, and loose or damaged terminals.

2-62-2 Testing.

- a. Shut down generator set.
- b. Open battery access door and disconnect negative battery cable.
- c. Remove control box top panel, paragraph 2-15-1.
- d. Set multimeter for ohms, and using Wiring Diagram FO-2 as a guide, check wires for continuity.
- e. If no repair is needed, install control box top panel, paragraph 2-15-4, connect negative battery cable, and close battery access door.

2-62-3 Repair.

- a. Replace individual wires, damaged terminal ends, clamps, and tie wraps.
- b. Ensure proper connection of wires not indicating continuity.

2-63 DIAGNOSTIC CONNECTOR.

NOTE

The diagnostic connector can be used as an aid in troubleshooting. Refer to FIGURE 2-17 and TABLE 2-9.

NOTE

Diagnostic connector is a component of the control box harness assembly, but can be removed and installed separately as follows.

2-63-1 Inspection.

- a. Shut down generator set.
- b. Open battery access door and disconnect negative battery cable.
- c. Inspect diagnostic connector for cracks, breaks, corrosion, bent terminals, bumps, or other indications of damage.
- d. Inspect cap for cracks, corrosion or broken chain.
- e. Inspect gasket for tears and deterioration.
- f. Replace any defective part.
- g. If no repair is needed, connect negative battery cable and close battery access door.

2-63-2 Removal.

- a. Shut down generator set.

- b. Open battery access door and disconnect negative battery cable.
- c. Remove control box top panel, paragraph 2-15-1.
- d. Loosen rear outer ring and plastic insert from diagnostic connector (60, FIGURE 2-14).
- e. Tag and disconnect electrical leads to diagnostic connector (60) by inseting removal tool into pins of connector.
- f. Remove screws (58) and nuts (59).
- g. Remove diagnostic connector cap (61), diagnostic connector (60), and gasket (62).

2-63-3 Installation.

- a. Install diagnostic connector (60, FIGURE 2-14), gasket (62), and cap (61) with screws (58) and nuts (59).
- b. Connect electrical leads to diagnostic connector (60) by using insert tool and remove tags.
- c. Install plastic insert and tighten rear outer ring on connector.
- d. Install control box top panel, paragraph 2-15-4.
- e. Connect negative battery cable. Close battery access door.

TABLE 2-9. Diagnostic Connector Connection Points.
 NOTE

The Diagnostic Connector can be used as a troubleshooting tool. Refer to FIGURE 2-17 for pin positions.

PIN	DESCRIPTION	EXPECTED OUTPUT*
B	Chassis ground (GND)	Continuity 0 volts
C	DC paralleling voltage for governor synchronization	0-20 VDC (*,5)
D	Chassis ground (GND)	Continuity 0 volts
E	Paralleling voltage for voltage regulator	0-20 VAC set freq. (*,5)
F	DC exciter field voltage (positive)	0-60 VDC (*,6)
G	DC paralleling voltage for governor synchronization	0-20 VDC (*,5)
H	Paralleling voltage for voltage regulator	0-20 VAC set freq.(*)
J	DC exciter field voltage (negative)	0-60 VDC(*,7)
M	DC voltage input to governor	24 VDC(*)
N	DC starter motor solenoid coil	24 VDC (2 or 3)
O	DC voltage across fuel pump (Aux)	24 VDC (1)
P	DC voltage S1 terminal 7	24 VDC (2)
S	DC voltage across engine fuel solenoid coil	24 VDC (*)
T	DC voltage across starter crank relay coil	24 VDC (2 or 3)
U	DC voltage (output of DC circuit breaker)	24 VDC
V	DC voltage across output circuit interrupter coil	24 VDC (*)
X	DC starter motor (motor side of solenoid contacts)	24 VDC (2 or 3)
Z	DC voltage across fuel level contacts	24 VDC (4)
a	DC voltage across low oil pressure switch	0 volts (*)
b	DC voltage across low oil pressure switch	24 VDC (4)
c	DC voltage across ether bottle solenoid coil	24 VDC when selected (2)
d	DC battery charging voltage	24-27.6 VDC
x	Input frequency sensing voltage to governor	2-6 volts, 0-4000 Hz (3, 8)
y	Input frequency sensing voltage to governor	2-6 volts, 0-4000 Hz (3, 8)
*	With generator set operating (refers to all others not numbered)	
(1)	Auxiliary fuel pump in operation (note fuel level), MASTER SWITCH in PRIME & RUN AUX FUEL position	
(2)	During engine starting	
(3)	Use DEAD CRANK switch	
(4)	MASTER SWITCH in PRIME & RUN position	
(5)	AC CIRCUIT INTERRUPTER closed	
(6)	Read between pins F and J	
(7)	Read between pins J and F	
(8)	Read between pins x and y	

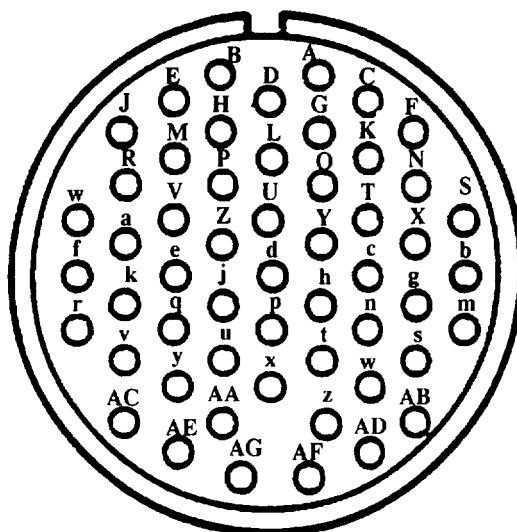

FIGURE 2-17. Diagnostic Connector Pin Positions

2-64 PARRALLEL CONNECTOR.

NOTE

Parallel connector is a component of control box harness assembly, but can be removed and installed separately as follows.

2-64-1 Inspection.

- a. Shut down generator set.
- b. Inspect parallel connector for cracks, corrosion, stripped or damaged threads, evidence of shorting or other damage.
- c. Inspect cap for cracks, corrosion, and broken chain.
- d. Inspect gasket for tears and deterioration.
- e. Replace defective parts.

2-64-2 Removal.

- a. Shut down generator set.
- b. Open battery access door and disconnect negative battery cable.
- c. Remove control box top panel, paragraph 2-15-1.
- d. Tag and disconnect parallel connector (65, FIGURE 2-14) electrical leads by inserting removal tool into pins of connector.
- e. Remove screws (63), nuts (64), and cap (66).
- f. Remove parallel connector (65) and gasket (67).

2-64-3 Installation.

- a. Install parallel connector (65, FIGURE 2-14), gasket (67), and cap (66) with screws (63) and nuts (64).
- b. Connect electrical leads using insert tool and remove tags.

- c. Install control box) top panel, paragraph 2-15-4.
- d. Connect negative battery cable. Close battery access door.

2-65 LOAD MEASURING UNIT.

2-65-1 Inspection.

- a. Shut down generator set.
- b. Inspect load measuring unit for damaged case, cracked or broken terminal lugs, and loose or missing hardware.

2-65-2 Removal.

- a. Shut down generator set.
- b. Open battery access door and disconnect negative battery cable.
- c. Remove control box top panel, paragraph 2-15-1.
- d. Release control panel by turning two fasteners and lower control panel slowly.
- e. Tag and disconnect load measuring unit (69, FIGURE 2-14) electrical leads.
- f. Remove screws (68) and load measuring unit (69).

2-65-3 Installation.

- a. Install load measuring unit (69, FIGURE 2-14) with screws (68).
- b. Connect all electrical leads and remove tags.
- c. Install control box top panel, paragraph 2-15-4.
- d. Raise and secure control panel.
- e. Connect negative battery cable. Close battery access door.

2-66 RESISTOR-DIODE ASSEMBLY.

2-66-1 Inspection.

- a. Shut down generator set.
- b. Inspect resistor diode assembly for cracks, breaks, corrosion, bent terminals, and other damage.

2-66-2 Testing.

- a. Shut down generator set.
- b. Open battery access door and disconnect negative battery cable.
- c. Release control panel by turning two fasteners and lower control panel slowly.
- d. Set multimeter for ohms and measure resistance across resistors R10, R11, and R12. Multimeter indication should be between 7.125 and 7.875 ohms for each resistor.
- e. Using multimeter, measure resistance across resistor R14. Multimeter indication should be between 61.75 and 68.25 ohms for MEP-805A generator set, and between 38 and 42 ohms for MEP-815A generator set.
- f. Using multimeter, measure resistance across resistor R15. Multimeter indication should be between 1235 and 1365 ohms.

- g. Using multimeter, measure resistance across resistors R6 and R8. Multimeter indication should be between 4750 and 5250 ohms.
- h. Using multimeter, measure resistance across resistors R7 and R9. Multimeter indication should be between 2850 and 3150 ohms.

NOTE

Isolate diode before testing.

- i. Connect positive lead of multimeter to cathode side and negative lead to anode side of each diode CR1, CR2, CR3, and CR4. Refer to FIGURE 2-18. Note ohms indication on multimeter for each diode.

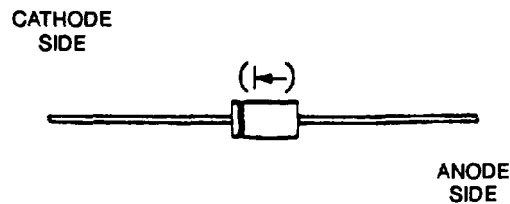

FIGURE 2-18. Diode Identification

- j. Reverse multimeter leads so positive lead is connected to anode side and negative lead is connected to cathode side of each diode CR1, CR2, CR3, and CR4. Note ohms indication on multimeter for each diode.
 - k. Multimeter indications should be 1:10 ratio or greater.
 - l. If any indications are other than above, replace defective component.
 - m. If no repair is needed, install control box top panel, paragraph 2-15-4.
 - n. Raise and secure control panel.
 - o. Connect negative battery cable and close battery access door.
- 2-66-3 Removal.
- a. Shut down generator set.
 - b. Open battery access door and disconnect negative battery cable.
 - c. Remove control box top panel, paragraph 2-15-1.
 - d. Tag and disconnect resistor diode assembly (71, FIGURE 2-14) electrical leads.
 - e. Remove screws (70) and resistor diode assembly (71).
- 2-66-4 Repair.

Repair resistor diode assembly (71, FIGURE 2-14) by replacing resistors (72) and diodes (73).

2-66-5

- a. Install resistor diode assembly (71, FIGURE 2-14) and secure with screws (70).
- b. Connect electrical leads and remove tags.

- c. Install control box top panel, paragraph 2-15-4.
- d. Connect negative battery cable. Close battery access door.

2-67 CONTROL PANEL.

2-67-1 Removal.

- a. Shut down generator set.
- b. Open battery access door and disconnect negative battery cable.
- c. Remove press to test lights from control panel (do not unsolder wires), paragraph 2-21-3.
- d. Remove VOLTAGE adjust potentiometer from control panel (do not remove wires), paragraph 2-34-2.
- e. Remove FREQUENCY adjust potentiometer from control panel (do not remove wires), paragraph 2-35-2.
- f. Tag and disconnect all electrical leads to remaining indicators and switches on control panel (10, FIGURE 2-19).
- g. Remove screw (1), nut (2), and strap (3).
- h. Remove bolts (4) and (6), nuts (5) and (7), bracket (9), clamp (8), and control panel (10) from control box assembly.
- i. Remove bolts (11), nuts (12), and hinge (13) from control box assembly.

2-67-2 Inspection.

Inspect control panel (10, FIGURE 2-19) for dents, cracks, loose paint, and corrosion.

2-67-3 Repair.

WARNING

Wear a protective mask and gloves when sanding CARC painted surfaces. CARC paint dust is a health hazard and could cause personal injury if warning is not followed.

- a. Repair all dents, cracks, and remove all loose paint.
- b. Remove light corrosion with fine grit abrasive paper (Item 16, Appendix C).
- c. Repaint surface in accordance with TM 43-0139. (F) Refer to applicable directives.

2-67-4 Installation.

- a. Install hinge (13, FIGURE 2-19) on control box assembly with bolts (11) and nuts (12).
- b. Install control panel (10), clamp (8), and bracket (9) on control box assembly with bolts (4) and (6), and nuts (5) and (7).
- c. Install strap (3) on control panel (10) with screw (1) and nut (2).
- d. Connect all electrical wires to indicators and switches as tagged. Remove tags.
- e. Install press to test lights, paragraph 2-21-4.
- f. Install VOLTAGE adjust potentiometer, paragraph 2-34-4.
- g. Install FREQUENCY adjust potentiometer, paragraph 2-35-4.

h. Connect negative battery cable. Close battery access door.

2-68 CONTROL PANEL FRAME.

2-68-1 Removal.

- a. Shut down generator set.
- b. Open battery access door and disconnect negative battery cable.
- c. Remove control box assembly, paragraph 2-19-2.
- d. Remove control panel, paragraph 2-67-1.
- e. Remove diagnostic connector, paragraph 2-63-2 (do not remove wires).
- f. Remove parallel connector, paragraph 2-64-2 (do not remove wires).
- g. Remove CONVENIENCE RECEPTACLE, paragraph 2-46-3; GROUND FAULT CIRCUIT INTERRUPTER, paragraph 2-47-3; and malfunction indicator panel, paragraph 2-48-3.
- h. Remove bolts (14 and 16, FIGURE 2-19), nuts (15) and (17), damp (18), and control panel frame (19) from control box assembly.
- i. If necessary, drill out rivets (20), (22), and (24) and remove identification plates (21), (23), and (25).

2-68-2 Inspection.

Inspect control panel frame (19, FIGURE 2-19) for dents, cracks, loose paint, and corrosion.

2-68-3 Repair.

WARNING

Wear a protective mask and gloves when sanding CARC painted surfaces. CARC paint dust is a health hazard and could cause personal injury if warning is not followed.

- a. Repair all dents and cracks, and remove all loose paint.
- b. Remove light corrosion with fine grit abrasive paper (Item 16, Appendix C).
- c. Repaint surface in accordance with TM 434139. (F) Refer to applicable directives.

2-68-4 Installation.

- a. Install control panel frame (19, FIGURE 2-19) and damp (18) to control box assembly with bolts (14) and (16) and nuts (15) and (17).
- b. If removed, install identification plates (21), (23), and (25) on control panel frame (19) with rivets (20), (22), and (24).
- c. Install malfunction indicator panel, paragraph 2-48-4; GROUND FAULT CIRCUIT INTERRUPTER, paragraph 2-47-4; CONVENIENCE RECEPTACLE, paragraph 2-46-4; parallel connector, paragraph 2-64-3; and diagnostic connector, Paragraph 2-63-3.
- d. Install control panel, paragraph 2-67-4.
- e. Install control box assembly, paragraph 2-19-4.
- f. Connect negative battery cable and close battery access door.

2-69 CONTROL BOX SIDE PANELS.

2-69-1 Removal.

- a. Shut down generator set.
- b. Open battery access door and disconnect negative battery cable.
- c. Remove control box top panel, paragraph 2-15-1.
- d. Remove bolts (16, 26, and 28, FIGURE 2-19), nuts (17) and (27), and control box side panels (29) and (30) from generator set.
- e. Remove bolts (31), nuts (32), and air deflector (33) from side panel (30).

2-69-2 Inspection.

- a. Inspect side panels (29 and 30, FIGURE 2-19) and air deflector (33) for dents, cracks, loose paint, and corrosion.
- b. Inspect for missing or damaged cage nuts (43).

2-69-3 Repair.

WARNING

Wear a protective mask and gloves when sanding CARC painted surfaces. CARC paint dust is a health hazard and could cause personal injury if warning is not followed.

- a. Repair all dents and cracks, and remove all loose paint.
- b. Remove light corrosion with fine grit abrasive paper (Item 16, Appendix C).
- c. Repaint surface in accordance with TM 43-0139. (F) Refer to applicable directives.
- d. Replace missing or damaged cage nuts.

2-69-4 Installation.

- a. Apply a light mat of sealant (Item 18, Appendix C) to flanges of air deflector (33, FIGURE 2-19).
- b. Install air deflector (33) on control box side panel (30) with bolts (31) and nuts (32).
- c. Install control box side panels (29) and (30) on generator set with bolts (16), (26), and (28) and nuts (17) and (27). Ensure center bolt (16) and nut (17) on left side panel secures clamp (18).
- d. Install control box top panel, paragraph 2-15-4.
- e. Connect negative battery cable. Close battery access door.

2-70 CONTROL BOX BOTTOM.

2-70-1 Removal.

- a. Shut down generator set.
- b. Open battery access door and disconnect negative battery cable.
- c. Remove control box assembly, paragraph 2-19-2.
- d. Remove control panel frame, paragraph 2-68-1.

- e. Remove control box side panels, paragraph 2-69-1.
 - f. Remove control box components, paragraphs 2-42 through 2-50, 2-52 through 2-61, 2-65, and 2-66.
 - g. Contact Direct Support Maintenance to remove AC voltage regulator and control box harness.
 - h. Remove screws (34, FIGURE 2-19) and bracket (35) from control box bottom (42).
 - i. Remove screws (36), nuts (37), and relay tracks (38) from control box bottom (42).
 - j. Remove screws (39), nuts (40), and latch plate (41) from control box bottom (42).
- 2-70-2 Inspection.
- a. Inspect control box bottom (42, FIGURE 2-19) for dents, cracks, loose paint, and corrosion.
 - b. Inspect for missing or damaged cage nuts (43).
- 2-70-3 Repair.

WARNING

Wear a protective mask and gloves when sanding CARC painted surfaces. CARC paint dust is a health hazard and could cause personal injury if warning is not followed.

- a. Repair all dents and cracks, and remove all loose paint.
- b. Remove light corrosion with fine grit abrasive paper (Item 16, Appendix C).
- c. Repaint surface in accordance with TM 43-0139. (F) Refer to applicable directives.
- d. Replace missing or damaged cage nuts.

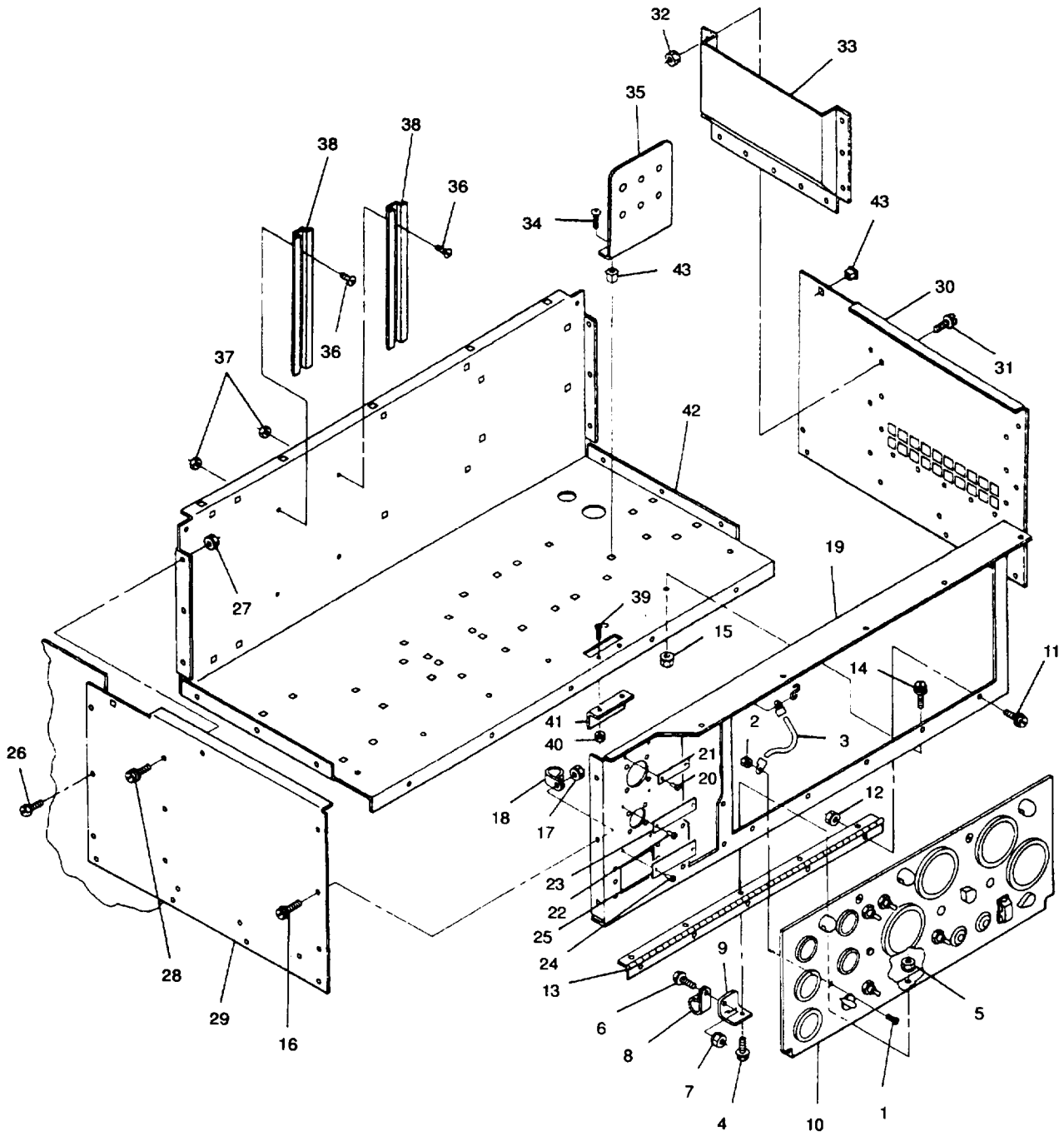

FIGURE 2-19. Control Box Panels

2-70-4 Installation.

- a. Install latch plate (41, FIGURE 2-19) on control box bottom (42) with screws (39) and nuts (49).
- b. Install relay tracks (38) on control box bottom (42) with screws (36) and nuts (37).
- c. Install bracket (35) on control box bottom (42) with screws (34).
- d. Contact Direct Support Maintenance to install control box harness and AC voltage regulator.
- e. Install control box components, paragraphs 2-42 through 2-50, 2-52 through 2-61, 2-65, and 2-66.
- f. Install control box side panels, paragraph 2-69-4.
- g. Install control panel frame, paragraph 2-68-4.
- h. Install control box assembly, paragraph 2-19-4.
- i. Connect negative battery cable and close battery access door.

Section XI. MAINTENANCE OF AIR INTAKE AND EXHAUST SYSTEM

2-71 MUFFLER AND EXHAUST PIPE.

2-71-1 Removal.

- a. Shut down generator set.
- b. Remove top housing panel and top housing frame, paragraph 2-16-1 and open engine access doors.

WARNING

The exhaust system can get very hot. Allow system to cool before performing maintenance. Failure to follow these instructions could result in severe burns and injuries.

- c. Remove clamp (1, FIGURE 2-20).
- d. Open bands (2) and separate muffler (3) and pipe (4). Remove muffler (3) from generator set.
- e. Remove bolts (5), lockwashers (6), washers (7), nuts (10), and muffler supports (8).
- f. Loosen exhaust pipe clamp (9) at turbocharger outlet.
- g. Remove left side air deflector and sufficient hardware securing top section floor panel, paragraph 2-16-1. to allow removal of exhaust pipe (4) from generator set.

2-71-2 Inspection.

- a. Shut down generator set.
- b. Remove top housing panel and top housing frame, paragraph 2-16-1.
- c. Open engine access doors.
- d. Inspect muffler (3, FIGURE 2-20) and pipe for cracks, excessive corrosion, clogging, and other damage.
- e. Replace damaged parts.
- f. Install top housing frame and top housing panel, paragraph 2-16-4. Close engine access doors.

2-71-3 Installation.

- a. Install muffler supports (8, FIGURE 2-20) with bolts (5), lockwashers (6), washers (7), and nuts (10).
- b. Install pipe (4) with clamp (9). Do not tighten clamp (9).
- c. Install left side air deflector and hardware securing top section floor panel, paragraph 2-16-4.
- d. Couple muffler (3) to pipe (4) with clamp (1). Do not tighten clamp (1).
- e. Secure muffler (3) to supports (8) with bands (2).
- f. Tighten clamps (1) and (9).
- g. Install top housing frame and top housing panel, paragraph 2-16-4. Close engine access doors.

2-72 AIR RESTRICTION INDICATOR.

2-72-1 Inspection.

- a. Shut down generator set.
- b. Open left side engine access doors.

WARNING

The exhaust system can get very hot. Allow system to cool before checking air restriction indicator. Failure to follow these instructions could result in severe burns and injuries.

- c. Inspect air restriction indicator (1, FIGURE 2-21) for cracks, stripped threads, or other obvious damage.
- d. Close engine access doors.

2-72-2 Removal.

- a. Shut down generator set.
- b. Open left side engine access doors.
- c. Unscrew air restriction indicator (1, FIGURE 2-21) from air cleaner housing (7).

2-72-3 Installation.

- a. Install air restriction indicator (1, FIGURE 2-21) on air cleaner housing (7). Tighten hand tight only.
- b. Close engine access doors.

2-73 AIR CLEANER ASSEMBLY.

2-73-1 Inspection.

- a. Shut down generator set.

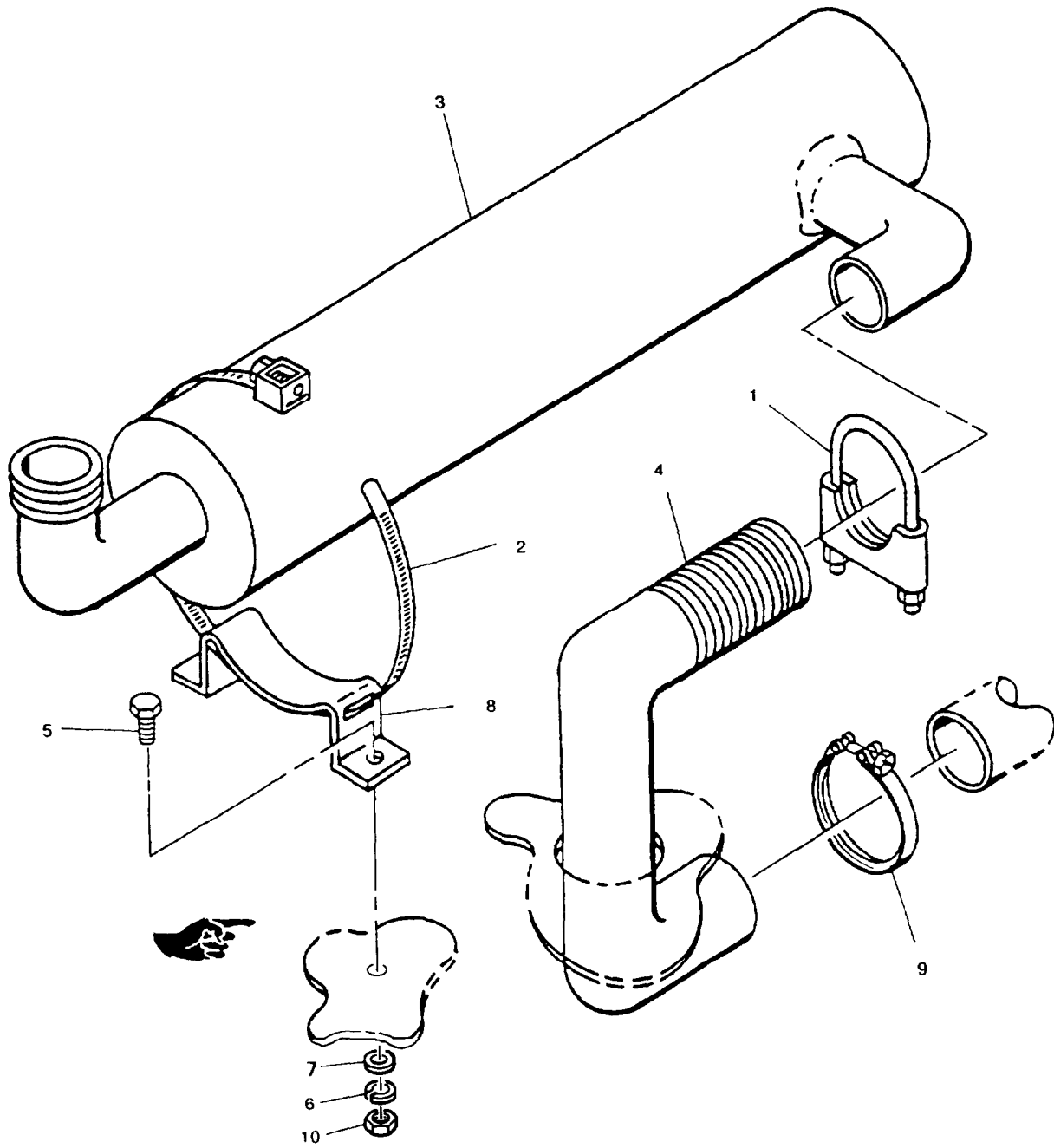

FIGURE 2-20. Muffler and Exhaust Pipe

- b. Open battery access door and disconnect negative battery cable.
- c. Remove control box assembly, paragraph 2-19-2.
- d. Inspect air cleaner assembly and mounting bracket for cracks, dents, and other damage (FIGURE 2-21).
- e. Install control box assembly, paragraph 2-19-4.
- f. Connect negative battery cable. Close battery access door.

2-73-2 Service.

- a. Remove air cleaner element, paragraph 2-74-1.
- b. Wipe inside of air cleaner housing with cleaning cloth (Item 8, Appendix C).
- c. Install new air cleaner element, paragraph 2-74-3.

2-73-3 Removal.

- a. Shut down generator set.
- b. Open battery access door and disconnect negative battery cable.
- c. Remove control box assembly, paragraph 2-19-2.
- d. Loosen clamp (2, FIGURE 2-21) and remove hose (15) from air cleaner housing (7).
- e. Remove bolts (3), washers (4), lockwashers (5), nuts (6), mounting bracket (11), and air cleaner assembly from generator set.
- f. Remove bolts (8), nuts (10), lockwashers (9), and mounting bracket (11) from air cleaner assembly.

2-73-4 Installation.

- a. Install mounting bracket (11, FIGURE 2-21) on air cleaner assembly with bolts (8), lockwashers (9), and nuts (10).
- b. Install air cleaner assembly and mounting bracket (11) on generator set with bolts (3), washers (4), lockwashers (5), and nuts (6).
- c. Install hose (15) and damp (2) on air cleaner housing (7). Tighten clamp (2).
- d. Install control box assembly. paragraph 2-19-4.
- e. Connect negative battery cable. Close battery access door.

2-74 AIR FILTER ELEMENT

2-74-1 Removal.

- a. Shut down generator set.
- b. Open air cleaner access door.
- c. Loosen wing nut caged to cover (12, FIGURE 2-21) and remove cover (12) from air cleaner housing (7).
- d. Remove wing nut (13) and filter element (14) from air cleaner housing (7).

2-74-2 Inspection.

- a. Shut down generator set.

- b. Remove air cleaner element, paragraph 2-74-1.
- c. Inspect element (14, FIGURE 2-21) for debris and damage, replace as necessary.
- d. Wipe inside of air cleaner housing (7) with cleaning cloth (Item 8, Appendix C).
- e. Install air cleaner element, paragraph 2-74-3.

2-74-3 Installation

- a. Install filter element (14, FIGURE 2-21) in air cleaner housing (7) and tighten wing nut (13).
- b. Install cover (12) on air cleaner housing (7), tighten caged wing nut.
- c. Close air cleaner access door.

2-75 AIR CLEANER TUBING AND BREATHER.

2-75-1 Inspection

- a. Shut down generator set.
- b. Open engine access doors.
- c. Inspect all tubing for cracks, tears, and holes.
- d. Inspect clamps for cracks.
- e. Inspect breather and cover for dents, cracks, and corrosion.
- f. Remove wing nut (21, FIGURE 2-21), washer (22), cover (23), rubber seal (24), and element (25) from breather (20).
- g. Inspect breather element for dogs, tears, or other damage.
- h. Inspect threaded parts for damaged or stripped threads.
- i. Replace parts as necessary.
- j. Install element (25), rubber seal (24), cover (23), washer (22), and wing nut (21) on breather (20).
- k. Close engine access doors.

2-75-2 Service

- a. Remove air cleaner tubing and breather, paragraph 2-75-3.

WARNING

Dry cleaning solvent inflammable and toxic to eyes, skin, and respirator tract. Skin/eye protection required. Avoid repeated/prolonged contact. Good general ventilation is normally adequate.

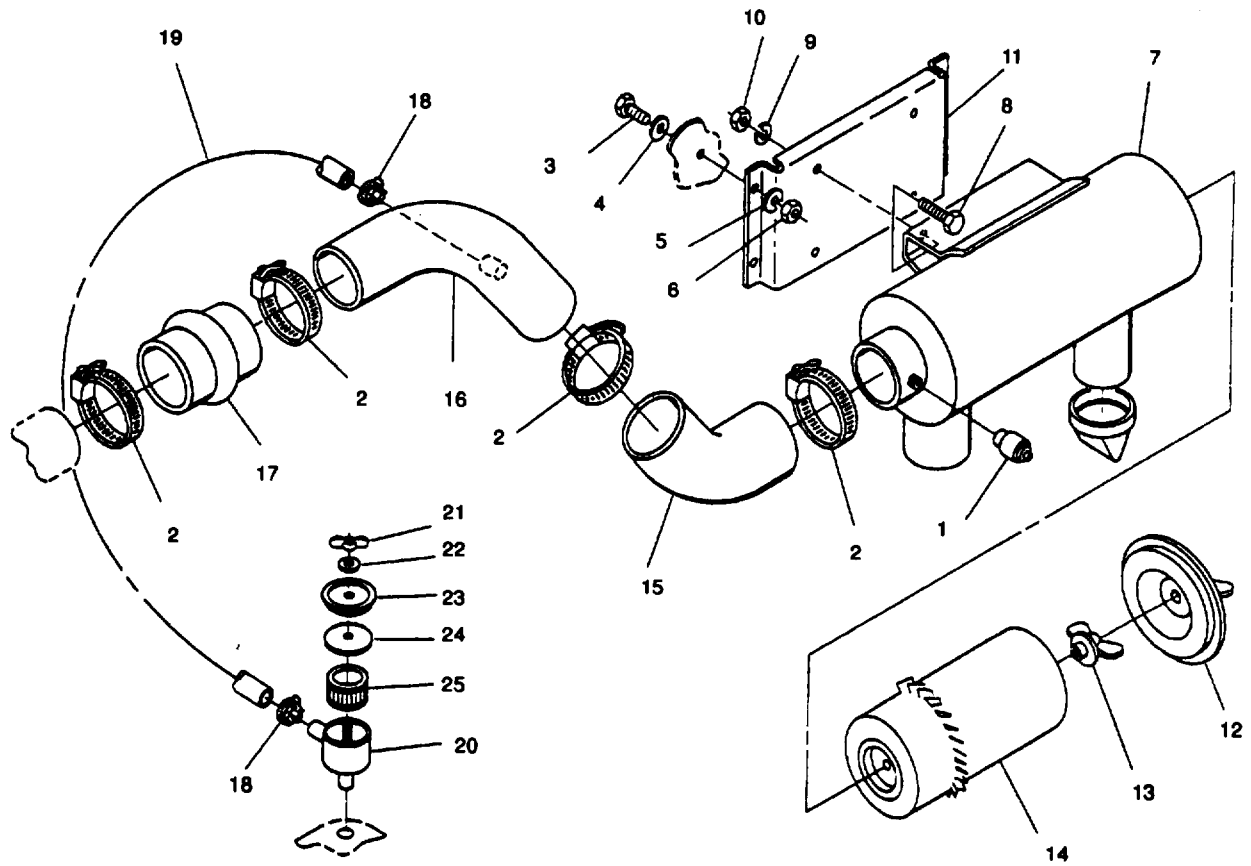

FIGURE 2-21. Air Cleaner Assembly

- b. Clean air cleaner tubing and breather housing with cleaning cloth (Item 8, Appendix C) dampened with dry cleaning solvent (Item 20, Appendix C).
- c. Replace breather element.
- d. Install air cleaner tubing and breather, paragraph 2-75-4.

2-75-3 Removal.

- a. Shut down generator set.
- b. Open engine access doors.
- c. Loosen clamps (2 and 18, FIGURE 2-21).
- d. Remove hose (15) from air cleaner housing (7) and tube (16).
- e. Remove tube (16) from breather hose (19) and hump hose (17).
- f. Remove hump hose (17) from turbocharger.
- g. Remove breather hose (19) from breather (20).
- h. Remove breather (20) from valve cover.
- i. Remove wing nut (21), washer (22), cover (23), rubber seal (24), and element (25) from breather (20).

2-75-4 Installation

- a. Install element (25, FIGURE 2-21), rubber seal (24), cover (23), washer (22), and wing nut (21) on breather (20).
- b. Install breather (20) in valve cover.
- c. Install hose (19) and clamp (18) on breather (20).
- d. Install hump hose (17) and clamp (2) on turbocharger.
- e. Install tube (16) and clamp (2) on hump hose (17).
- f. Install breather hose (19) and clamp (18) on tube (16).
- g. Install hose (15) and clamps (2) on tube (16) and air cleaner housing (7).
- h. Tighten clamps (2) and (18).
- i. Close engine access doors.

Section XII. MAINTENANCE OF COOLANT SYSTEM

2-76 COOLANT SYSTEM.

2-76-1 Testing

- a. Shut down generator set.

WARNING

Coolant can get very hot. Allow system to cool down before performing maintenance. Failure to follow these instructions could result in severe burns and injuries.

WARNING

Always remove radiator cap slowly to permit any pressure to escape. Failure to observe this warning could result in severe injury.

- b. Slowly remove radiator cap (1, FIGURE 2-23).
- c. Install coolant system pressure tester (ST255) in radiator neck
- d. Open engine access doors.
- e. Pump pressure tester until 8 psi is indicated, check coolant system for leaks.
- f. Pump pressure tester until 7 psi (± 1) is indicated and ensure radiator cap releases.
- g. Release pressure from pressure tester and remove from radiator neck.
- h. Install radiator cap (1).
- i. Close engine access doors.

2-76-2 Service.

- a. Shut down generator set.
- b. Open left side engine access door.
- c. Flush or drain coolant system in accordance with TM 750-254.
- d. Close engine access door.

2-77 RADIATOR FILLER HOSE AND PANEL.

2-77-1 Removal.

- a. Shut down generator set.
- b. Open engine access doors.
- c. Remove generator housing top panel, paragraph 2-16-1.

WARNING

Make sure DEAD CRANK switch is in OFF position. Failure to follow this warning could result in severe personal injury.

WARNING

Coolant can get very hot. Allow system to cool down before performing maintenance. Failure to follow these instructions could result in severe burns and injuries.

WARNING

Always remove radiator cap slowly to permit any pressure to escape. Failure to observe this warning could result in severe injury.

- d. Slowly remove radiator cap (1, FIGURE 2-23).

- e. Open radiator drain valve (28) and drain coolant/antifreeze into suitable container to a level below radiator filler hose (3) connection at radiator.
- f. Loosen clamps (2). Remove radiator filler hose (3) and clamps (2)
- g. Loosen clamp (4) and disconnect overflow hose (5) from radiator filler neck (9).
- h. Remove radiator fill panel (6) and filler neck (9) from generator set.
- i. Remove bolts (7), nuts (8), cap (1), and radiator filler neck (9) from radiator fill panel (6).

2-77-2 Inspection and Cleaning.

- a. Shut down generator set.
- b. Remove radiator filler hose and panel, paragraph 2-77-1.
- c. Inspect radiator filler hose (3, FIGURE 2-23) for cracks, holes, and rotting.
- d. Inspect filler panel (6), filler neck (9), and cap (1) for cracks, excessive corrosion, and other damage
- e. Clean light corrosion from filler hose attaching points with fine grit abrasive paper (Item 16, Appendix C).
- f. Replace damaged parts.
- g. Install radiator filler hose and panel, paragraph 2-77-3.

2-77-3 Installation.

- a. Install radiator filler neck (9, FIGURE 2-23) and cap (1) on radiator fill panel (6) with bolts (7) and nuts (8).
- b. Position radiator fill panel (6) and filler neck (9) in generator set and attach overflow hose (5) with clamp (4).
- c. Install radiator filler hose (3) on filler neck (9) and radiator (31) with clamps (2).
- d. Install generator housing top panel, paragraph 2-16-4.
- e. Close radiator drain valve (28) and add coolant/antifreeze to proper level, paragraph 2-1-2-2.

NOTE

If replacing radiator cap solder tab to radiator cap as shown in FIGURE 2-22.

- f. Install radiator cap (1).
- g. Start generator set. Allow unit to reach operating temperature and check for leaks.

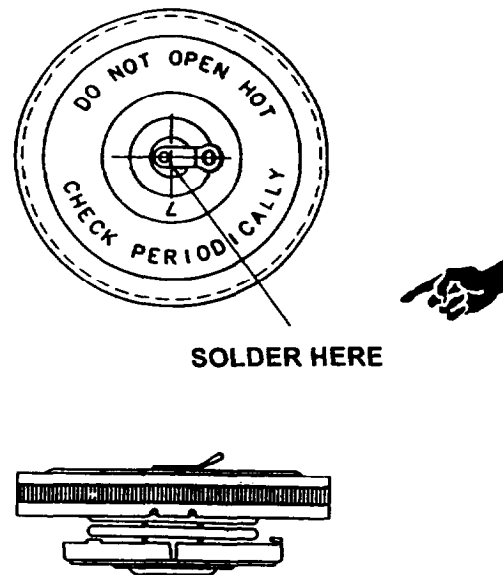

FIGURE 2-22. Radiator Cap

- h. Add coolant/antifreeze to overflow bottle as required.
- i. Close engine access doors.

2-78 FAN GUARDS.

2-78-1 Inspection.

- a. Shut down generator set.
- b. Open both side engine access doors.
- c. Inspect fan guards, brackets, and attaching hardware for damage, corrosion, and loose or missing hardware.
- d. Replace all damaged and missing components. Tighten all loose attaching hardware.
- e. Close engine access doors.

2-78-2 Removal.

- a. Shut down generator set.
- b. Open battery access door and disconnect negative battery cable.
- c. Open both side engine access doors.

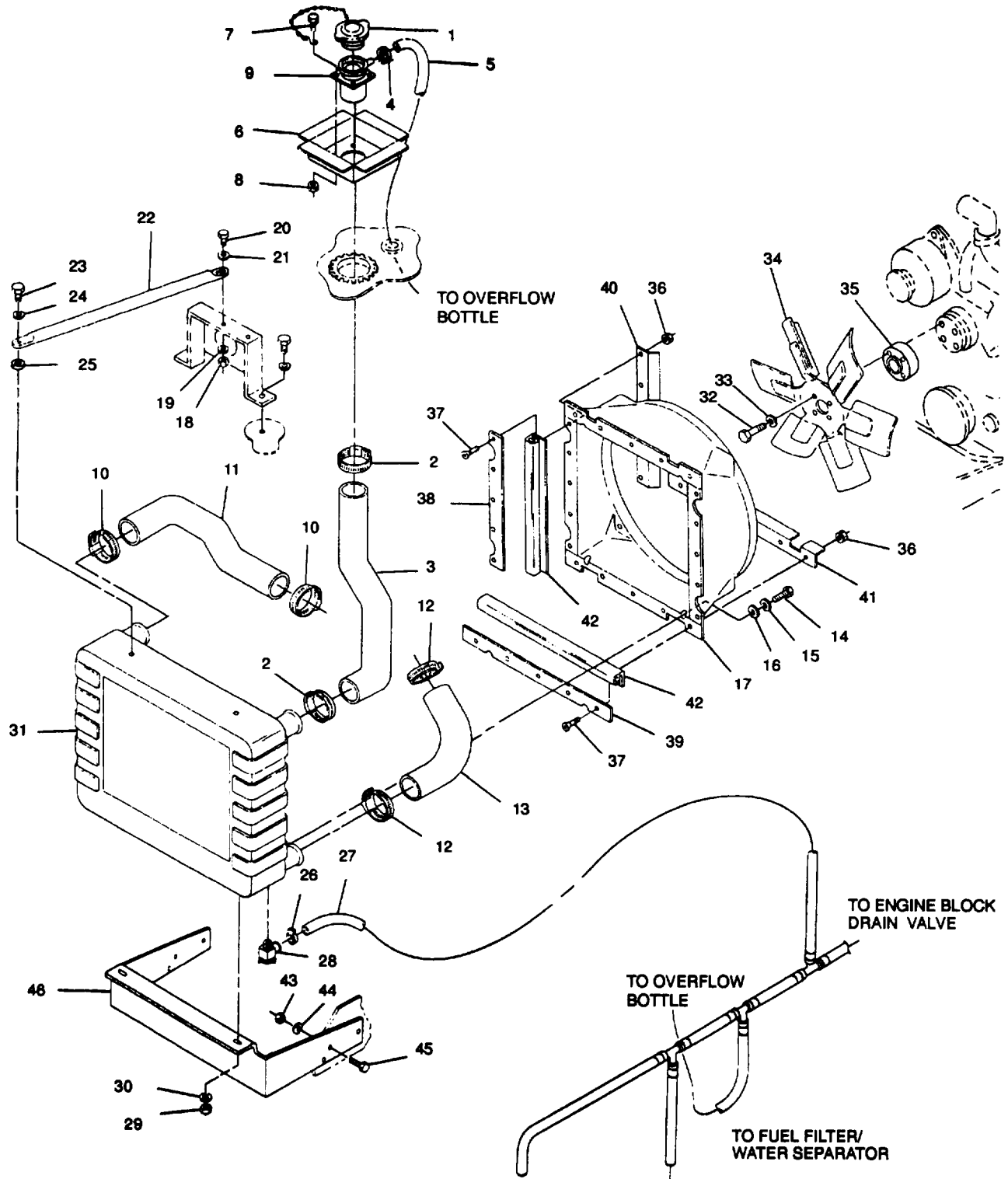

FIGURE 2-23. Coolant System

- d. Remove bolts (1, FIGURE 2-24), washers (2), nuts (3), end lockwashers (4) securing fans guards (5) and (6).
- e. Remove bolts (7), lockwashers (8), washers (9), and brackets (10) and (11) from radiator shroud.
- f. Remove bolt (12), lockwasher (13), and bracket (14) from engine head.
- g. Remove nut (15), lockwasher (16), washer (17), and bracket (18) from injection pump mount.
- h. Remove nut (19), lockwasher (20), bolt (21), and bracket (22) from alternator mount.

2-78-3 Installation.

- a. Install bolts (7, FIGURE 2-24), lockwashers (8), and washers (9) securing brackets (10) and (11) to radiator shroud.
- b. Install bracket (14) to engine head with bolt (12) and lockwasher (13).
- c. Install bracket (18) to injection pump mount with nut (15), lockwasher (16) and washer (17).
- d. Install bracket (22) to alternator mount with bolt (21), lockwasher (20), and nut (19).

NOTE

If damaged or if replacing fan guards (5 and 6), install protective edging (23), cut to fit.

- e. Install bolts (1), washers (2), nuts (3), and lockwashers (4) securing fan guards (5) and (6).
- f. Close both side engine access doors.
- g. Connect negative battery cable and close battery access door.

2-79 UPPER COOLANT HOSE.

2-79-1 Removal.

- a. Shut down generator set.
- b. Open battery access door and disconnect negative battery cable.
- c. Open engine access doors.

WARNING

Coolant can get very hot. Allow system to cool down before performing maintenance. Failure to follow these instructions could result in severe burns and injuries.

WARNING

Always remove radiator cap slowly to permit pressure to escape. Failure to observe this warning could result in severe injury.

- d. Slowly remove radiator cap (1, FIGURE 2-23).
- e. Remove fan guards, paragraph 2-78-2.

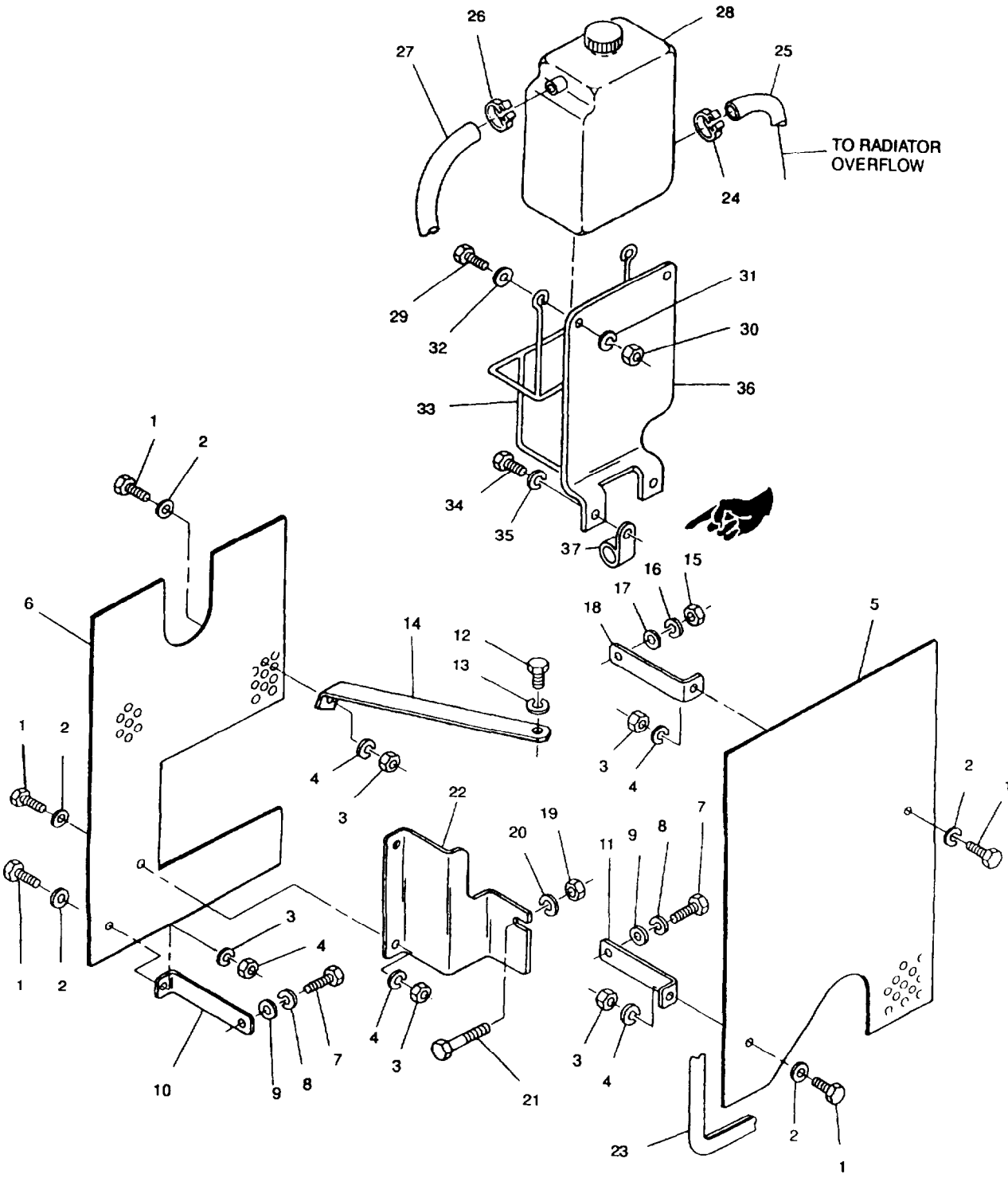

FIGURE 2-24. Fan Guards and Coolant Recovery System

- f. Open radiator drain valve (28) and drain coolant/antifreeze into suitable container.
- g. Loosen clamps (10). Remove upper coolant hose (11) and clamps (10).

2-79-2 Inspection and Cleaning.

- a. Shut down generator set.
- b. Remove upper coolant hose, paragraph 2-79-1.
- c. Inspect upper coolant hose (11, FIGURE 2-23) for cracks, holes, and rotting.
- d. Clean light corrosion from upper coolant hose attaching points with fine grit abrasive paper (Item 16, Appendix C).
- e. Install upper coolant hose, paragraph 2-79-3.

2-79-3 Installation.

- a. Install upper coolant hose (11, FIGURE 2-23) on thermostat housing opening and radiator (31) with clamps (10).
- b. Close radiator drain valve (28) and add coolant/antifreeze to proper level, paragraph 2-1-2-2.
- c. Install fan guards, paragraph 2-78-3.
- d. Install radiator cap (1).
- e. Connect negative battery cable and close battery access door.
- f. Start generator set. Allow unit to reach operating temperature and check for leaks.
- g. Add coolant/antifreeze to overflow bottle as required.
- h. Close engine access doors.

2-80 LOWER COOLANT HOSE.

2-80-1 Removal.

- a. Shut down generator set.
- b. Open battery access door and disconnect negative battery cable.
- c. Open engine access doors.

WARNING

Coolant can get very hot. Allow system to cool down before performing maintenance. Failure to follow these instructions could result in severe burns and injuries.

WARNING

Always remove radiator cap slowly to permit pressure to escape. Failure to observe this warning could result in severe injury.

- d. Slowly remove radiator cap (1, FIGURE 2-23).
- e. Remove fan guards, paragraph 2-78-2.
- f. Open radiator drain valve (28) and drain coolant into suitable container.

- g. Loosen clamps (12) and remove lower coolant hose (13).

2-80-2 Inspection and Cleaning.

- a. Shut down generator set.
- b. Remove lower coolant hose, paragraph 2-80-1.
- c. Inspect lower coolant hose (13, FIGURE 2-23) for cracks, holes, and rotting.
- d. Clean exterior of lower radiator outlet tube with fine grit abrasive paper (Item 16, Appendix C).
- e. Install lower coolant hose, paragraph 2-80-3.

2-80-3 Installation

- a. Install lower coolant hose (13, FIGURE 2-23) on radiator outlet opening and water pump opening with clamps (12).
- b. Close radiator drain valve (28) and add coolant/antifreeze to proper level, paragraph 2-1-2-2.
- c. Install fan guards, paragraph 2-78-3.
- d. Install radiator cap (1).
- e. Connect negative battery cable and close battery access door.
- f. Start generator set. Allow unit to reach operating temperature and check for leaks.
- g. Add coolant/antifreeze to overflow bottle as required.
- h. Close engine access doors.

2-81 COOLANT OVERFLOW AND DRAIN HOSES.

2-81-1 Removal.

- a. Shut down generator set.
- b. Open battery access door and disconnect negative battery cable.
- c. Open engine access doors.
- d. Locate overflow or drain hose to be removed, as shown on FIGURE 2-23.
- e. Disconnect hose at both ends and remove from generator set.

2-81-2 Inspection

- a. Shut down generator set.
- b. Open engine access doors.
- c. Inspect hoses for cracks, holes, and rotting.
- d. Close engine access doors.

2-81-3 Installation.

- a. Install overflow or drain hose in generator set as removed.
- b. Close engine access doors.

- c. Connect negative battery cable and close battery access door.

2-82 RADIATOR.

2-82-1 Removal.

- a. Shut down generator set.
- b. Open engine access doors.
- c. Remove generator set top housing section, paragraph 2-16-1.

WARNING

Coolant can get very hot. Allow system to cool down before performing maintenance. Failure to follow these instructions could result in severe burns and injuries.

WARNING

Always remove radiator cap slowly to permit pressure to escape. Failure to follow this warning could result in severe injury.

- d. Slowly remove radiator cap (1, FIGURE 2-23).
- e. Remove fan guards, paragraph 2-78-2.
- f. Open radiator drain valve (28) and drain coolant/antifreeze into suitable container.
- g. Remove radiator filler hose and panel assembly, paragraph 2-77-1.
- h. Remove upper coolant hose, paragraph 2-79-1.
- i. Remove lower coolant hose, paragraph 2-80-1.
- j. Remove bolts (14), lockwashers (15), and flatwashers (16) and allow shroud (17) to rest on fan.
- k. Remove nuts (18), lockwashers (19), bolts (20), and washers (21) securing support rods (22) to bracket on engine.
- l. Remove bolts (23), lockwashers (24), support rods (22), and spacers (25) from radiator (31).
- m. Loosen clamp (26) and disconnect radiator drain hose (27) from radiator drain valve (28).
- n. Remove nuts (29) and lockwashers (30) from radiator mounting points.
- o. Lift radiator (31) up and out of generator set housing.
- p. Remove radiator drain valve (28) from radiator (31).

2-82-2 Inspection and Cleaning

- a. Shut down generator set.
- b. Remove radiator, paragraph 2-82-1.
- c. Inspect radiator for excessive corrosion, cracks, or bent cooling fins.
- d. Check inside of radiator for corrosion and scale.

WARNING

Use clean, low pressure air, 30 psi maximum. Wear protective glasses when using compressed air. Failure to follow these instructions could result in eye injury.

WARNING

Dry cleaning solvent is flammable and toxic to eyes, skin, and respiratory tract. Skin/eye protection required. Avoid repeated/prolonged contact. Good general ventilation is normally adequate.

- e. Clean dirt particles from radiator core air passages using filtered, compressed air.
- f. Clean exterior surface of radiator with dry cleaning solvent (Item 20, Appendix C).
- g. Install radiator, paragraph 2-82-4.

2-82-3 Repair.

Repair radiator by straightening bent radiator fins and soldering minor leaks.

2-82-4 Installation.

- a. Install drain valve (28, FIGURE 2-23) in radiator (31).
- b. Position radiator (31) on radiator mount, and install nuts (29) and lockwashers (30).
- c. Install shroud (17) on radiator (31) with bolts (14), lockwashers (15), and flatwashers (16).
- d. Connect radiator drain hose (27) on radiator drain valve (28) with clamp (26).
- e. Connect support rods (22) to radiator (31) with spacers (25), lockwashers (24) and bolts (23).
- f. Attach support rods (22) to bracket on engine with bolts (20), washers (21), lockwashers(19), and nuts (1 8).
- g. Install lower coolant hose, paragraph 2-80-3.
- h. Install upper coolant hose, paragraph 2-79-3.
- i. Install radiator filler hose and panel assembly, paragraph 2-77-3.
- j. Install fan guards, paragraph 2-78-3.
- k. Install generator set top housing section, paragraph 2-16-4.
- l. Ensure radiator drain valve (28) is closed and add coolant/antifreeze, to proper level, paragraph 2-1-2-2.
- m. Install radiator cap (1).
- n. Start generator set. Allow unit to reach operating temperature and check for leakage.
- o. Add coolant to overflow bottle as required.
- p. Close engine access doors.

2-83 GENERATOR SET COOLING

2-83-1 Removal.

- a. Shut down generator set.

- b. Open battery access door and disconnect negative battery cable.
- c. Open engine access doors.
- d. Remove fan guards, paragraph 2-78-2.
- e. Remove bolts (14, FIGURE 2-23), washers (16), and lockwashers (15) and allow shroud (17) to rest on fan (34).
- f. Remove bolts (32), lockwashers (33), fan (34), spacer (35), and shroud (17) from generator set.
- g. Remove nuts (36), screws (37), stiffeners (38) and (39), supports (40) and (41), and seals (42) from each side of shroud (17).

2-83-2 Inspection.

- a. Shut down generator set.
- b. Remove cooling fan, paragraph 2-83-1.
- c. Inspect fan (34, FIGURE 2-23) and blades for cracks, bends, loose rivets, or other damage.
- d. Inspect seals (42), supports (40) and (41), and stiffeners (38) and (39) for damage.
- e. Replace damaged parts.
- f. Install cooling fan, paragraph 2-83-3.

2-83-3 Installation

- a. Install seals (42, FIGURE 2-23), supports (40) and (41), and stiffeners (38) and (39) on each side of shroud (17) with screws (37) and nuts (36).
- b. Position fan (34), spacer (35), and shroud (17) in generator set and secure with bolts (32) and lockwashers (33). Torque bolts (32) to 24 ft-lbs (32.5 Nm).
- c. Install fan shroud (17) with bolts (14), lockwashers (15), and washers (16).
- d. Install fan guards, paragraph 2-78-3.
- e. Close engine access doors.
- f. Connect negative battery cable and close battery access door.

2-84 FAN BELT

2-84-1 Inspection.

- a. Shut down generator set.
- b. Open battery access door and disconnect negative battery cable.
- c. Open engine access doors.
- d. Inspect fan belt (6, FIGURE 2-25) for frays, cracks, oil soaking, and other damage.
- e. Replace fan belt that shows any of above or cannot be adjusted for proper tension.
- f. Close engine access doors.
- g. Connect negative battery cable and close battery access door.

2-84-2 Test and Adjustment.

NOTE

Run engine for 5 minutes if belt is cold. If belt is hot, let cool for 10 to 15 minutes.

- a. Shut down generator set.
- b. Open battery access door and disconnect negative battery cable.
- c. Open engine access doors.
- d. Check fan belt (6, FIGURE 2-25) for 1/2 inch (1 .27 cm) deflection midway between alternator pulley (3) and crankshaft pulley (5).
- e. If fan belt needs adjustment, loosen alternator mounting bolt (1) and nut (2).

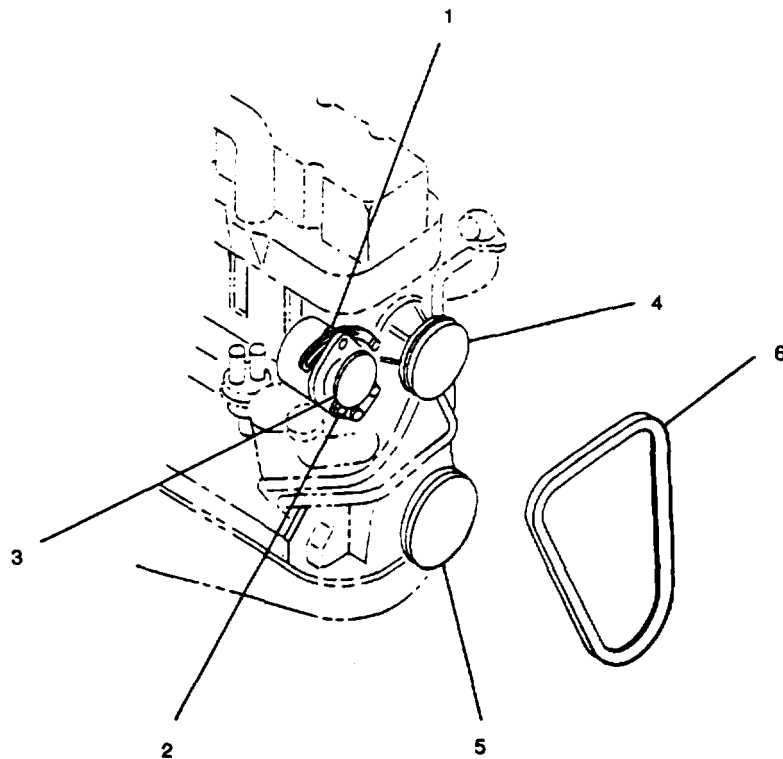

FIGURE 2-25. Fan Belt

CAUTION

Do not pry against alternator rear frame. Damage to alternator or mounting brackets could occur.

- f. Apply outward pressure to alternator front frame until belt tension is correct.
- g. Tighten alternator mounting bolt (1) and nut (2).
- h. Close engine access doors.

- i. Connect negative battery cable and close battery access door.

2-84-3 Removal.

- a. Shut down generator set.
- b. Open battery access door and disconnect negative battery cable.
- c. Open engine access doors.
- d. Remove fan guards, paragraph 2-78-2.
- e. Loosen alternator mounting bolt (1, FIGURE 2-25) and nut (2).
- f. Pivot alternator to relieve tension on fan belt (6), and remove belt from alternator pulley (3), fan pulley (4), and crankshaft pulley (5).
- g. Slip belt (6) over fan (34, FIGURE 2-23) and remove belt from generator set.

2-84-4 Installation.

- a. Slip fan belt (6, FIGURE 2-25) over fan (34, FIGURE 2-23).
- b. Install belt (6, FIGURE 2-25) onto alternator pulley (3), fan pulley (4), and crankshaft pulley (5).
- c. Adjust tension on fan belt (6), paragraph 2-84-2.
- d. Install fan guards, paragraph 2-78-3.
- e. Close engine access doors.
- f. Connect negative battery cable and close battery access door.

2-85 COOLANT RECOVERY SYSTEM.

2-85-1 Inspection.

- a. Shut down generator set.
- b. Open right side engine access doors.
- c. Inspect coolant recovery system components for cracks, holes, or other damage.
- d. Close right side engine access doors.

2-85-2 Removal.

- a. Shut down generator set.
- b. Open right side engine access doors

WARNING

Coolant can get very hot. Allow system to cool down before performing maintenance.
Failure to follow these instructions could result in severe burns and injuries.

- c. Loosen clamp (24, FIGURE 2-24) and disconnect hose (25) from overflow bottle (28) and drain coolant into suitable container.
- d. Loosen clamp (26) and disconnect hose (27) from overflow bottle (28).
- e. Remove overflow bottle (28) from wire holder (33).

- f. Remove bolts (29), nuts (30), lockwashers (31), flatwashers (32), and wire holder (33) from mount (36).
- g. Remove bolts (34), lockwashers (35), clamp (37), and mount (36) from engine.

2-85-3 Installation

- a. Install mount (36, FIGURE 2-24) and clamp (37) on engine with bolts (34) and lockwashers (35).
- b. Install wire holder (33) on mount (36) with bolts (29), flatwashers (32), lockwashers (31), and nuts (30).
- c. Install coolant overflow bottle (28) in holder (33) and connect hoses (25) and (27) with clamps (24) and (26).
- d. Fill overflow bottle (28) with coolant to the COLD level. Refer to TABLE 2-1 for proper coolant.
- e. Start generator set, check for leaks, and run until normal operating temperature is reached.
- f. Add coolant to HOT level of overflow bottle (28) and close right side engine access doors.

Section XIII. MAINTENANCE OF FUEL SYSTEM

2-86 LOW PRESSURE FUEL LINES AND FITTINGS.

2-86-1 Removal.

- a. Shut down generator set.
- b. Open battery access door and disconnect negative battery cable.
- c. Identify fuel line or fitting that is damaged or leaking and must be removed as shown in FIGURE 2-26.
- d. Disconnect fuel line at both ends and remove any clamps.
- e. Remove fuel line or fitting from generator set.
- f. Cover or cap all openings.

2-86-2 Installation.

- a. Remove any caps and position fuel line or fitting in generator set.
- b. Install any clamps as removed and connect fuel line at both ends.
- c. Connect negative battery cable and close battery access door.
- d. Start generator set and check for fuel leaks.
- e. Shut down generator set and close all access doors.

2-87 AUXILIARY FUEL PUMP

2-87-1 Inspection.

- a. Shut down generator set.
- b. Inspect auxiliary fuel pump (8, FIGURE 2-26) for leaks, cracks, missing hardware, loose connections, and other damage.

2-87-2 Testing

- a. Shut down generator set.

- b. Connect generator set to auxiliary fuel supply (ensure auxiliary fuel supply is no more than 6 feet (1.83 m) below generator set).
- c. Open left side engine access doors.

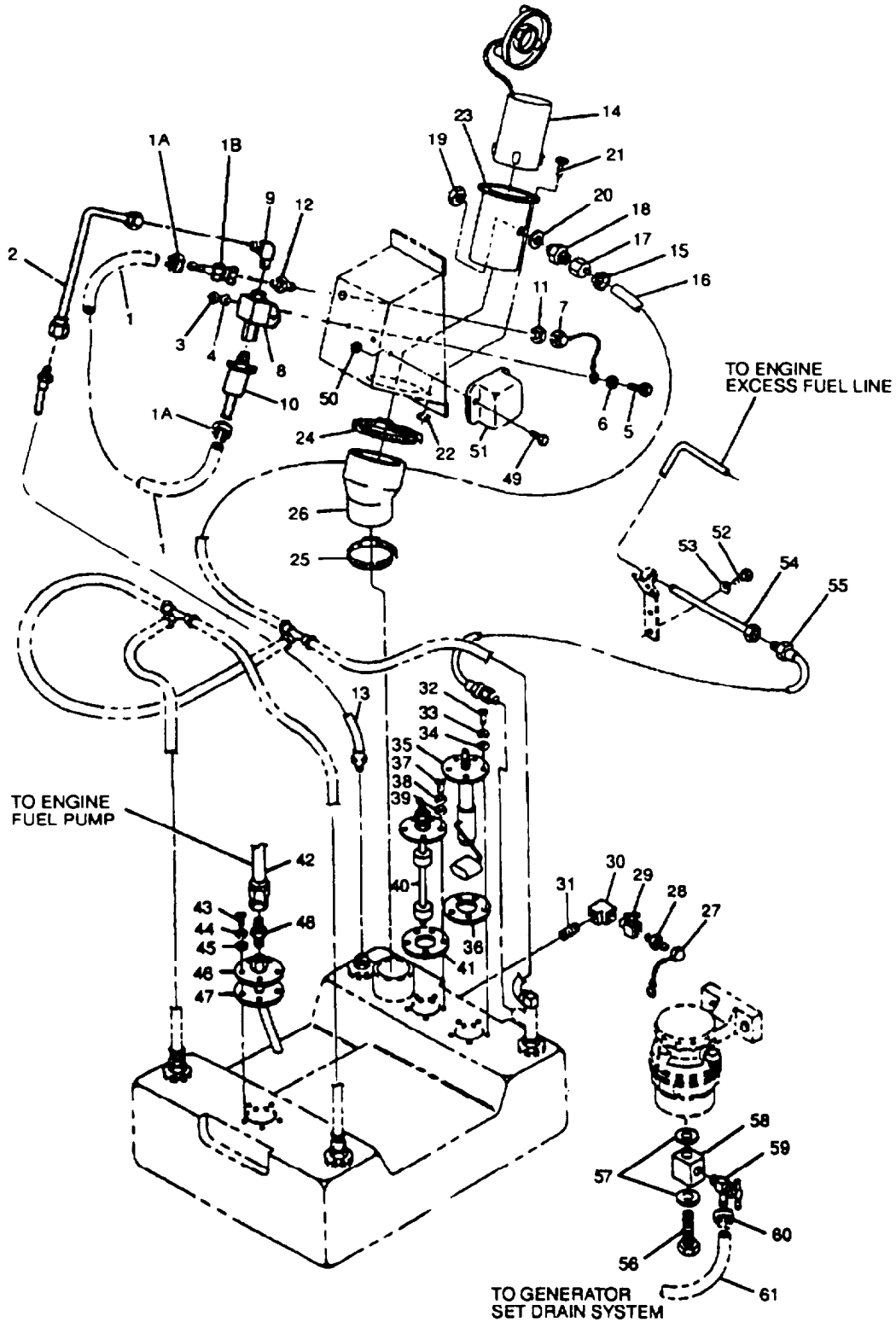

FIGURE 2-26. Fuel Tank Filler Neck and Low Pressure Fuel System

- d. Disconnect auxiliary fuel pump outlet line (13, FIGURE 2-26) at fuel tank fitting and place disconnected end in measuring container.
- e. Move generator set MASTER SWITCH to PRIME & RUN AUX FUEL position for 1 minute and return MASTER SWITCH to OFF position.
- f. Measuring container should have collected at least 36 ounces (1 .06 liters) of fuel.
- g. Replace auxiliary fuel pump if delivery amount is other than above.
- h. Connect auxiliary fuel pump outlet line (13) at fuel tank fitting.
- i. Disconnect generator set from auxiliary fuel supply.
- j. Close engine access doors.

2-87-3 Removal.

- a. Shut down generator set.
- b. Open battery access door and disconnect negative battery cable.
- c. Open left side engine access doors.
- d. Tag and disconnect auxiliary fuel pump (8, FIGURE 2-26) electrical connector.
- e. Loosen clamps (1a). Disconnect filter (10) and remove adapter fitting (1b) from filler neck panel fitting (12). Remove adapter fitting (1b) from auxiliary fuel pump (8). Cap fuel inlet hose.
- f. Disconnect auxiliary fuel outlet line (2) from auxiliary fuel pump (8).
- g. Remove nuts (3), lockwashers (4), bolts (5), washers (6), cap and chain assembly (7), and auxiliary fuel pump (8).
- h. Remove fitting (9) from auxiliary fuel pump.
- i. If necessary, remove nut (11) and fitting (12) from fuel filler panel.

2-87-4 Installation.

- a. If removed, install fitting (12, FIGURE 2-26) and nut (11) in fuel filler panel.
- b. Install fitting (9) in auxiliary fuel pump (8).
- c. Install auxiliary fuel pump (8) and cap and chain assembly (7) in generator set with bolts (5), washers (6), lockwashers (4), and nuts (3).
- d. Connect auxiliary fuel outlet line (2) to auxiliary fuel pump (8).
- e. Remove caps from fuel inlet hose (1). Install filter (10) on auxiliary fuel pump (8). Install adapter fitting (1b) on fuel inlet hose (1) and connect adapter fitting (1b) to filler neck panel fitting (12). Connect other end of fuel inlet hose to filter (10). Tighten clamps (1a).
- f. Connect auxiliary fuel pump electrical connector and remove tag.
- g. Connect negative battery cable. Close battery access door.
- h. Move generator set MASTER SWITCH to PRIME AND RUN AUX FUEL position and check for fuel leaks.
- i. Return MASTER SWITCH to OFF position and close engine access doors.

2-88 FUEL TANK FILLER NECK.

2-88-1 REMOVAL.

- a. Shut down generator set.
- b. Open battery access door and disconnect negative battery cable.

WARNING

Diesel fuel is flammable and toxic to eyes, skin, and respiratory tract. Skin/eye protection required. Avoid repeated/prolonged contact. Good general ventilation is normally adequate.

- c. Remove cap (27, FIGURE 2-26), open fuel drain valve (29) and drain fuel into suitable container.
- d. Open left side engine access doors.
- e. Remove filler neck cap and tube assembly (14).
- f. Loosen clamp (15) and disconnect hose (16) from adapter (17).
- g. Remove adapter (17) from fitting (18).
- h. Remove nut (19), washer (20), and fitting(18) from side of filler neck (23).
- i. Remove bolts (21) and nuts (22) securing filler neck (23) to generator set housing.
- j. Remove clamps (24) and (25), hose (26), and filler neck (23) from fuel tank opening. Cover fuel tank opening.

2-88-2 Inspection.

- a. Shut down generator set.
- b. Remove fuel tank filler neck, paragraph 2-88-1.
- c. Inspect hose (26, FIGURE 2-26) for cracking, wear, or other damage.
- d. Inspect filler neck (23) for corrosion, cracking, or other damage.
- e. Inspect filler neck cap and tube assembly (14) for damage.
- f. Install fuel tank filler neck, paragraph 2-88-3.

2-88-3 Installation

- a. Position hose (26, FIGURE 2-26), clamps (24) and (25), and filler neck (23) on fuel tank.
- b. Install bolts (21) and nuts (22) securing filler neck (23) to generator set housing.
- c. Tighten clamps (24) and (25).
- d. Install fitting (18), washer (20), and nut (19) in side of filler neck (23).
- e. Install adapter (17) on fitting (18) and connect hose (16) to adapter (17) with clamp (15).
- f. Install filler neck cap and tube assembly (14).
- g. Close fuel drain valve (29), install cap (27), and service fuel tank Refer to TABLE 2-2 for proper fuel.
- h. Connect negative battery cable. Close battery access door and engine access doors.

2-89 FUEL DRAIN VALVE

2-89-1 Removal.

- a. Shut down generator set.
- b. Open battery access door and disconnect negative battery cable.
- c. Open left side engine access doors.
- d. Remove cap and chain assembly (27, FIGURE 2-26) from adapter (28).

WARNING

Diesel fuel is flammable and toxic to eyes, skin, and respiratory tract. Skin/eye protection required. Avoid repeated/prolonged contact. Good general ventilation is normally adequate.

- e. Open drain valve (29) and drain fuel into suitable container.
- f. Remove drain valve (29) and adapter (28) from elbow (30).
- g. Remove adapter (28) from drain valve (29).
- h. If necessary, remove elbow (30) and adapter (31) from fuel tank fitting.

2-89-2 Installation.

- a. If removed, install adapter (31, FIGURE 2-26) and elbow (30) in fuel tank fitting.
- b. Install fuel drain valve (29) into elbow (30).
- c. Install adapter (28) into drain valve (29), and cap and chain assembly (27) on adapter (28).
- d. Ensure fuel drain valve (29) is closed and service fuel tank. Refer to TABLE 2-2 for proper fuel.
- e. Check fuel drain valve and fittings for leakage.
- f. Close left side engine access doors.
- g. Connect negative battery cable and close battery access door.

2-90 FUEL LEVEL SENDER.

2-90-1 Inspection.

- a. Shut down generator set.
- b. Open left side engine access doors.
- c. Inspect fuel level sender (35, FIGURE 2-26) for loose connections and mounting, and other damage.
- d. Close engine access doors.

2-90-2 Removal.

- a. Shut down generator set.
- b. Open battery access door and disconnect negative battery cable.
- c. Open left side engine access doors and disconnect fuel level sender (35, FIGURE 2-26) electrical lead.

NOTE

Mark position of float when removing sender. Float must be in same position when installing to ensure clearance with fuel tank.

- d. Remove screws (32), lockwashers (33), flatwashers (34), fuel level sender (35), and gasket (36) from generator set fuel tank
- e. Cover opening in fuel tank.

2-90-3 Testing.

- a. Shut down generator set.
- b. Remove fuel level sender, paragraph 2-90-2.
- c. Position fuel level sender in vertical position, similar to position as installed in fuel tank.
- d. Set multimeter for ohms and connect positive lead to fuel level sender terminal, and negative lead to sender ground.
- e. With fuel level sender arm resting freely in what would be an empty position, multimeter should indicate between 216 and 264 ohms.
- f. Move fuel level sender arm up to what would be a full position and multimeter should indicate between 29.7 and 36.3 ohms.
- g. Replace fuel level sender if indications are not as above.
- h. Install fuel level sender, paragraph 2-90-4.

2-90-4 Installation.

- a. Remove cover in fuel tank opening.
- b. Thoroughly clean mating surfaces for new gasket (36, FIGURE 2-26). Ensure no foreign material enters fuel tank. Apply sealant (item 21, Appendix C) to both sides of gasket (36).
- c. Insert fuel level sender (35, FIGURE 2-26) and gasket (36) into fuel tank. Ensure float is in same position as removed.
- d. Install screws (32), lockwashers (33), and flatwashers (34).
- e. Connect electrical lead, remove tag, and close left side engine access doors.
- f. Connect negative battery cable. Close battery access door.

2-91 LOW FUEL LEVEL/AUXILIARY FUEL PUMP FLOAT SWITCH

2-91-1 Inspection.

- a. Shut down generator set.
- b. Open left side engine access doors.
- c. Inspect low fuel level/auxiliary fuel pump float switch (40, FIGURE 2-26) for loose connections and mounting, and other damage.
- d. Close left side engine access doors.

2-91-2 Removal.

- a. Shut down generator set.

- b. Open battery access door and disconnect negative battery cable.
- c. Open left side engine access doors, tag and disconnect low fuel level/auxiliary fuel pump float switch (40, FIGURE 2-26) electrical connector.
- d. Remove screws (37), lockwashers (36), flatwashers (39), float switch (40), and gasket (41) from fuel tank.
- e. Cover opening in fuel tank.

2-91-3 Testing.

- a. Shut down generator set.
- b. Remove low fuel level/auxiliary fuel pump float switch, paragraph 2-91-2.
- c. Position float switch in vertical position, similar to position as installed in fuel tank.
- d. Set multimeter for ohms and connect positive lead to pin 2 for top float and negative lead to pin 1 for top float of float switch electrical connector.
- e. With upper or lower float moving toward the down position, multimeter should indicate continuity 1/4-inch before float reaches the down position.
- f. Move upper float to the full up position, multimeter should indicate open circuit.
- g. Disconnect multimeter leads from pins 1 and 2 and connect positive lead to pins 3 and negative lead to pin of electrical connector.
- h. Repeat steps e and f, except with lower float.
- i. Replace low fuel level/auxiliary fuel pump float switch if indications are other than above.
- j. Install low fuel level/auxiliary fuel pump float switch, paragraph 2-91-4.

2-91-4 Installation.

- a. Loosen float switch plate adjusting nut.
- b. Remove cove in fuel tank opening.
- c. Thoroughly clean mating surfaces for new gasket (41, FIGURE 2-26). Ensure no foreign material enters fuel tank. Apply sealant (item 21, Appendix C) to both sides of gasket (41).
- d. Position gasket (41, FIGURE 2-26) and float switch (40) in fuel tank.
- e. Install screws (37), lockwashers (36), and flatwashers (39).
- f. Set float stem 1/16-inch from bottom of fuel tank. Tighten float switch adjusting nut.
- g. Connect electrical connector, remove tag and close left side engine access doors.
- h. Connect negative battery cable. Close battery access door.

2-92 FUEL PICKUP.

2-92-1 Removal.

- a. Shut down generator set.
- b. Open battery access door and disconnect negative battery cable.
- c. Open right side engine access doors and disconnect fuel line (42, FIGURE 2-26) from fitting (46).

NOTE

Mark position of fuel pickup before removing.

- d. Remove screws (43), lockwashers (44), flatwashers (45), fuel pickup (46), and gasket (47) from fuel tank.
- e. Remove fitting (48) from fuel pickup (46).
- f. Cover opening in fuel tank.

2-92-2 Inspection

- a. Shut down generator set.
- b. Remove fuel pickup, paragraph 2-92-1.
- c. Inspect fuel pickup and fitting for clogs, stripped threads, and other damage.
- d. Replace damaged parts.
- e. Install fuel pickup, paragraph 2-92-3.

2-92-3 Installation.

NOTE

Ensure fuel pickup is in same position as marked on removal.

- a. Remove cover in fuel tank opening.
- b. Thoroughly clean mating surfaces for new gasket (36, FIGURE 2-26). Ensure no foreign material enters fuel tank. Apply sealant (item 21, Appendix C) to both sides of gasket (36).
- c. Install gasket (47, FIGURE 2-26) and fuel pickup (46) in fuel tank with screws (43), lockwashers (44), and flatwashers (45).
- d. Install fitting (48) in fuel pickup (46).
- e. Connect fuel line (42) to fitting (48) and close right side engine access doors.
- f. Connect negative battery cable and close battery access door.

2-93 FUEL FLOAT MODULE.

2-93-1 Inspection.

- a. Shutdown generator set.
- b. Open left side engine access doors.

- c. Inspect fuel float module (51, FIGURE 2-26) for cracked housing, broken or damaged connectors and wiring, and other damage.
- d. Close left side engine access doors.

2-93-2 Testing.

- a. Shut down generator set.
- b. Open left side engine access doors.
- c. Disconnect fuel float module (51, FIGURE 2-26) electrical connector (J12) from fuel float switch connector (P12).
- d. Connect pins 1 and 2 of fuel float module electrical connector (J12) together with a jumper wire.
- e. Move MASTER SWITCH to PRIME& RUN AUX FUEL position and auxiliary fuel pump should start operating. Remove jumper wire and auxiliary fuel pump should stop operating.
- f. Start and operate generator set at rated voltage and frequency.
- g. Using jumper wire, make connection between pins 3 and 4 of fuel float module electrical connector (J1 2). Generator set should shut down after approximately 2 seconds and NO FUEL lamp on malfunction indicator panel should light.
- h. Replace fuel float module if operation is other than above.
- i. Close left side engine access doors.

2-93-3 Removal.

- a. Shut down generator set.
- b. Open battery access door and disconnect negative battery cable.
- c. Open left side engine access doors, tag and disconnect electrical connectors from fuel float module (51, FIGURE 2-26).
- d. Remove bolts (49), nuts (50), and fuel float module (51) from generator set.

2-93-4 Installation.

- a. Install fuel float module (51, FIGURE 2-26) in generator set with bolts (49) and nuts (50).
- b. Connect electrical connectors, remove tags, and close left side engine access doors.
- c. Connect negative battery cable and close battery access door.

NOTE

Maintenance for the fuel filter/water separator is found in the engine TM. Retain fuel filter drain valve assembly for use with new filters.

2-93A FUEL FILTER/DRAIN VALVE ASSEMBLY.

2-93A-1 Removal.

- a. Remove clamp (60, FIGURE 2-26) and hose (61) from drain valve assembly.
- b. Remove bolt (56), washers (57), and adapter (56). Discard washers (57).
- c. Remove valve (59) from adapter (58).

2-93A-2 Inspection. Check valve assembly for defects and proper operation.

2-93A-3 Installation.

- a. Replace adapter (56) on valve (59).
- b. Install new washers (57) and bolt (56) to adapter (58) and tighten to bottom of fuel filter/water separator.
- c. Install hose (61) and clamp (60) to drain valve (59).

2-94 ETHER CYLINDER.

2-94-1 Removal.

- a. Shut down generator set.
- b. Open right side engine access doors.
- c. Loosen wing nut (1, FIGURE 2-27) and unscrew ether cylinder (2) from ether solenoid valve (14).
- d. Install cap (15) in solenoid valve (14).
- e. Remove nuts (3), lockwashers (4), bolts (5), washers (6), and ether cylinder bracket assembly (7) from generator set housing.

2-94-2 Inspection.

- a. Shut down generator set.
- b. Open right side engine access doors.
- c. Inspect cylinder bracket assembly for cracks, corrosion, stripped or damaged threads, or other damage.
- d. Replace defective parts.
- e. Close right side engine access doors.

2-94-3 Installation.

- a. Install bracket assembly (7, FIGURE 2-27) on generator set housing with bolts (5), washers (6), lockwashers (4), and nuts (3).
- b. Remove cap (15) from ether solenoid valve (14).
- c. Insert ether cylinder (2) through bracket (7) and screw into ether solenoid valve (14).

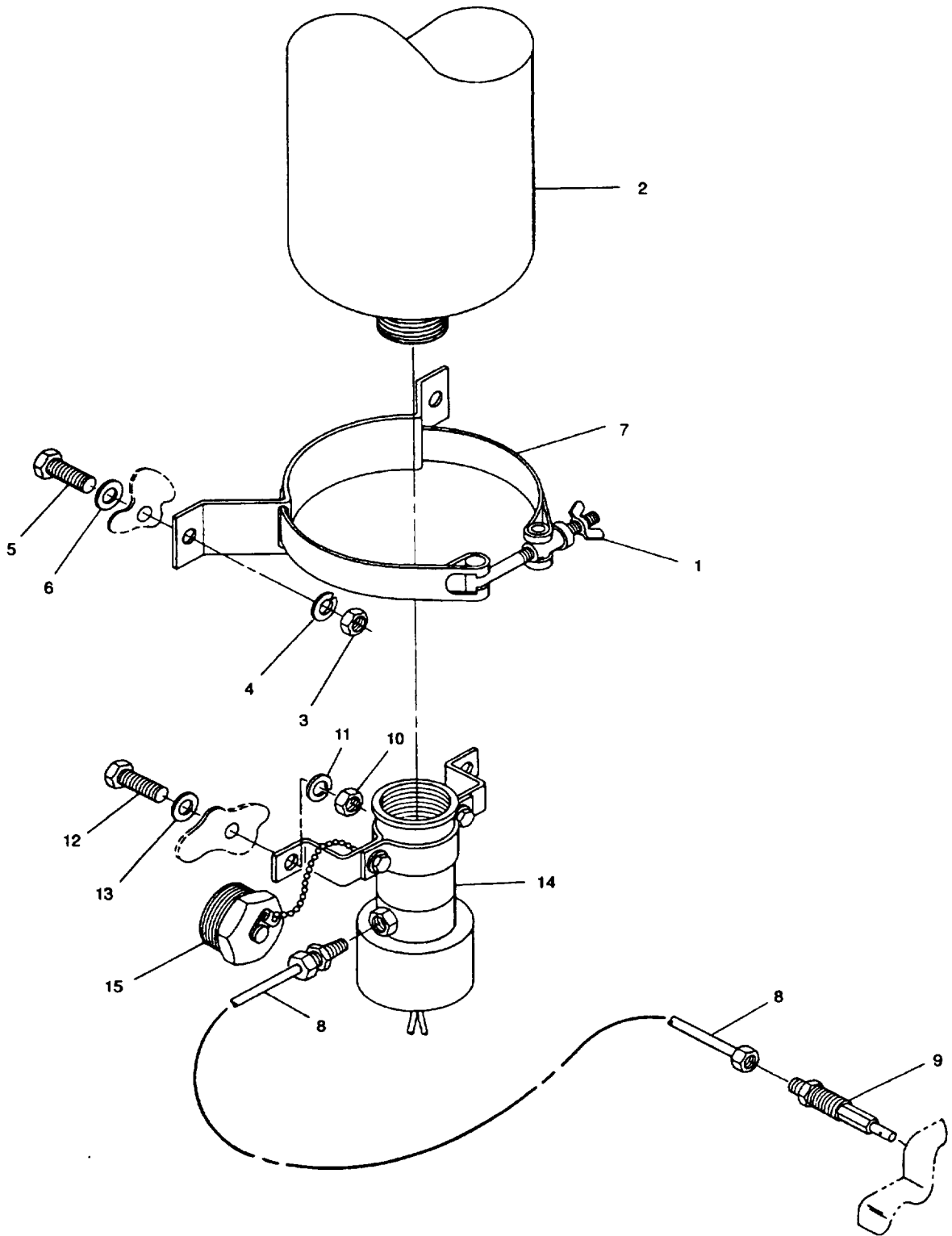

FIGURE 2-27. Ether Start System

- d. Close clamp (7) and tighten wing nut (1).
- e. Close right side engine access doors.

2-95 ETHER SOLENOID VALVE.

2-95-1 Removal.

- a. Shut down generator set.
- b. Open battery access door and disconnect negative battery cable.
- c. Open right side engine access doors.
- d. Tag and disconnect ether solenoid valve (14, FIGURE 2-27) electrical leads.
- e. Remove tube assembly (8) from ether solenoid valve (14) and spray nozzle (9).
- f. Remove ether cylinder (2) from ether solenoid valve (14), paragraph 2-94-1.
- g. Remove nuts (10), lockwashers (11), bolts (12), washers (13), and ether solenoid valve (14) from generator set housing.
- h. Remove spray nozzle (9) from engine intake manifold.

2-95-2 Inspection.

- a. Shut down generator set.
- b. Remove ether solenoid valve, paragraph 2-95-1.
- c. Inspect solenoid valve for cracks, corrosion, damaged threads, evidence of shorting, or other damage.
- d. Inspect tube assembly for cracks, breaks, pinching, damaged threads, or other damage.
- e. Inspect nozzle for cracks, corrosion, clogging, or other damaged.
- f. Replace any defective parts.
- g. Install ether solenoid valve, paragraph 2-95-3.

2-95-3 Installation.

- a. Install ether solenoid valve(14, FIGURE 2-27) on generator set housing with bolts (12), washers (13), lockwashers (11), and nuts (10).
- b. Install ether cylinder (2) into ether solenoid valve (14), paragraph 2-94-3.
- c. Install spray nozzle (9) in engine intake manifold.
- d. Install tube assembly (8) to ether solenoid valve (14) and spray nozzle (9).
- e. Connect electrical leads, remove tags, and close right side engine access doors.
- f. Connect negative battery cable and close battery access door.

Section XIV. MAINTENANCE OF OUTPUT BOX ASSEMBLY

2-96 VOLTAGE RECONNECTION TERMINAL BOARD.

2-96-1 Inspection.

- a. Shut down generator set.
- b. Open output box access door.
- c. Inspect protective cover (3, FIGURE 2-28) and moveable terminal board (5) for cracks, breaks, corrosion, and other damage.
- d. Replace damaged parts.
- e. Close output box access door.

2-96-2 Removal.

- a. Shut down generator set.
- b. Open battery access door and disconnect negative battery cable.
- c. Open output box access door.
- d. Remove nuts (1, FIGURE 2-28), washers (2), and protective cover (3) from voltage reconnection terminal board assembly.
- e. Remove nuts (4) and moveable terminal board (5) from voltage reconnection terminal board assembly.

2-96-3 Installation.

- a. Install moveable terminal board (5, FIGURE 2-28) on voltage reconnection terminal board assembly with nuts (4).
- b. Install protective cover (3) on voltage reconnection terminal board assembly with washers (2) and nuts (1).
- c. Close output box access door.
- d. Connect negative battery cable and close battery access door.

2-97 OUTPUT BOX HARNESS.

2-97-1 Inspection.

- a. Shut down generator set.
- b. Inspect wiring harness (6, FIGURE 2-28) for burned, bent, corroded, and broken terminals.
- c. Inspect connectors for cracks, corrosion, stripped threads, bent or broken pins, and obvious damage.
- d. Inspect wire insulation for burns, deterioration, and chafing.

2-97-2 Testing.

- a. Shutdown generator set.
- b. Open battery access door and disconnect negative battery cable.

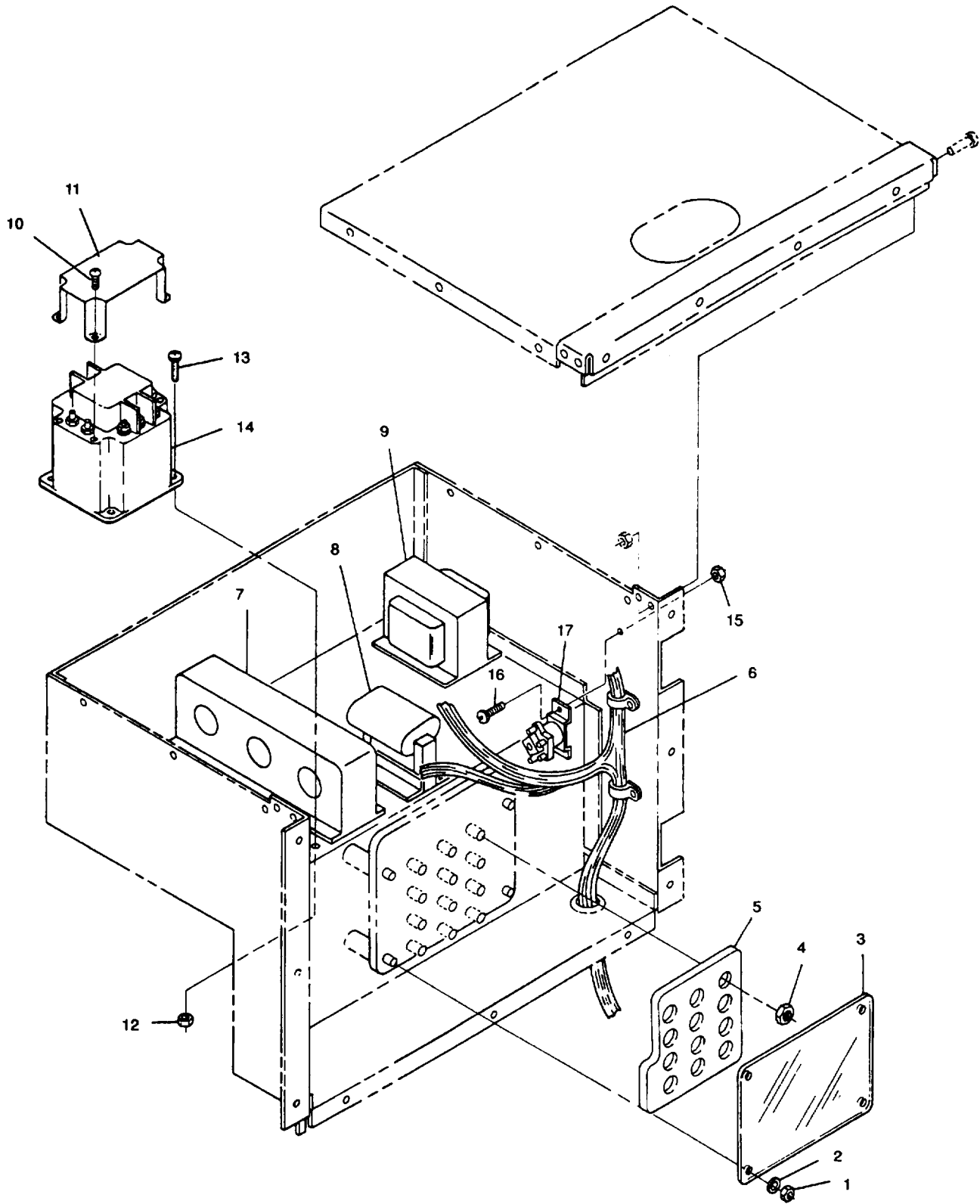

FIGURE 2-28. Output Box Assembly

- c. Open output box and engine access doors.
- d. Set multimeter for ohms, and test individual wires for continuity. Refer to Wiring Diagram FO-2 for wire identification.
- e. Close output box and engine access doors.
- f. Connect negative battery cable and close battery access door.

2-97-3 Repair.

- a. Shut down generator set.
- b. Open battery access door and disconnect negative battery cable.
- c. Open applicable access doors.
- d. Replace damaged terminals and securing hardware.
- e. Connect negative battery cable and close all access doors.

2-98 CURRENT TRANSFORMER.

2-98-1 Inspection.

- a. Shut down generator set.
- b. Open output box access door.
- c. Inspect current transformer (7, FIGURE 2-28) for security, cracked housing, broken or stripped terminals, and loose or missing hardware.
- d. Close output box access door.

2-98-2 Testing.

- a. Shut down generator set.
- b. Open battery access door and disconnect negative battery cable.
- c. Open output box access door.
- d. Tag and disconnect electrical leads from current transformer (7, FIGURE 2-28) secondary terminals.
- e. Set multimeter for ohms and check for continuity between secondary terminals A1 and A2, B1 and B2, and C1 and C2.
- f. If continuity is not present, current transformer is defective. Notify next higher level of maintenance.
- g. If continuity is present, connect electrical leads to secondary terminals and remove tags.
- h. Close output box access door.
- i. Connect negative battery cable and close battery access door.

2-99 DROOP CURRENT TRANSFORMER.

2-99-1 Inspection.

- a. Shutdown generator set.
- b. Open output box access door.
- c. Inspect droop current transformer (8, FIGURE 2-28) for cracked housing, security, broken wire terminals, loose or missing hardware, and other damage.
- d. Close output box access door.

2-100 POWER POTENTIAL TRANSFORMER

2-100-1 Inspection.

- a. Shutdown generator set.
- b. Open output box access door.
- c. Inspect power potential transformer (9, FIGURE 2-28) for security, cracked housing, broken wire terminals, loose or missing hardware, and other damage.
- d. Close output box access door.

2-101 AC CIRCUIT INTERRUPTER RELAY.

2-101-1 Inspection.

- a. Shut down generator set.
- b. Open output box access door.
- c. Inspect AC circuit interrupter relay (14, FIGURE 2-28) for security, cracked housing, broken wire terminals, and other damage.
- d. Close output box access door.

2-101-2 Testing.

- a. Shut down generator set.
- b. Open battery access door and disconnect negative battery cable.
- c. Open output box access door.
- d. Set multimeter for ohms and check for open circuits between terminals A1 and A2, B1 and B2, C1 and C2, and 11 and 12.
- e. Connect jumper wire from cranking relay terminal A1 to AC circuit interrupter relay terminal X.
- f. Connect negative battery cable.
- g. Check for closed circuits (continuity) between terminals A1 and A2, B1 and B2, C1 and C2, and 11 and 12.
- h. Disconnect negative battery cable.
- i. Replace AC circuit interrupter relay if indications are other than above.
- j. If replacement is not needed, remove jumper wire end close output box access door.
- k. Close output box access door.
- l. Connect negative battery cable and close battery access door.

2-101-3 Removal.

- a. Shut down generator set.
- b. Open battery access door and disconnect negative battery cable.
- c. Open output box access door.
- d. Remove screws (10, FIGURE 2-28) and cover (11) from AC circuit interrupter relay (14).
- e. Tag and disconnect AC circuit interrupter relay (14) electrical leads.
- f. Remove screws (13), nuts (12), and AC circuit interrupter relay (14) from output box.

2-101-4 Installation

- a. Install AC circuit interrupter relay (14, FIGURE 2-28) in output box with screws (13) and nuts (12).
- b. Connect electrical leads and remove tags.
- c. Install cover (11) on AC circuit interrupter relay (14) with screws (10).
- d. Close output box access door.
- e. Connect negative battery cable. Close battery access door.

2-102 CRANKING RELAY

2-102-1 Inspection.

- a. Shut down generator set.
- b. Open output box and right side engine access doors.
- c. Inspect cranking relay (17, FIGURE 2-28) for security, cracked housing, broken wire terminals, and other damage.
- d. Close access doors.

2-102-2 Testing.

- a. Shut down generator set.
- b. Open battery access door and disconnect negative battery cable.
- c. Open output box access door.
- d. Tag and disconnect wires from terminals X1, X2, and A2 of cranking relay (17, FIGURE 2-28).
- e. Connect a jumper wire between terminals A1 and X1 of cranking relay.
- f. Connect negative battery cable.
- g. Connect X2 wire disconnected in step d to cranking relay and listen for audible actuation.
- h. Set multimeter for ohms and check for continuity between terminals A1 and A2 of cranking relay. If no continuity is, cranking relay is defective and must be replaced.
- i. If replacement is not needed, disconnect negative battery cable.
- j. Remove jumper wire and connect remaining wires to cranking relay as tagged.

- k. Close output box access door.
- l. Connect negative battery cable and close battery access door.

2-102-3 Removal.

- a. Shut down generator set.
- b. Open battery access door and disconnect negative battery cable.
- c. Open output box and right side engine access doors.
- d. Tag and disconnect cranking relay (17, FIGURE 2-28) electrical leads.
- e. Remove screws (16), nuts (15), and cranking relay (17) from output box.

2-102-4 Installation

- a. Install cranking relay (17, FIGURE 2-28) with screws (16) and nuts (15).
- b. Connect electrical leads and remove tags.
- c. Close output box and right side engine access doors.
- d. Connect negative battery cable. Close battery access door.

2-103 LOAD OUTPUT TERMINAL BOARD.

2-103-1 Removal.

- a. Shut down generator set.
- b. Open battery access door and disconnect negative battery cable.
- c. Open load terminal board access door and disconnect load output cables L1, L2, L3, and L0 from load output terminal board
- d. Remove generator set housing rear panel, paragraph 2-18-1.
- e. Remove bolt (1, FIGURE 2-29), nut (2), flatwasher (3), and lockwasher (4) securing ground strap (15) to skid base.
- f. Remove bolts (5), lockwashers (6), and washers (7) securing terminal board assembly (12) to supports.
- g. Remove nuts (8) and washers (9), tag and disconnect all main power leads (10) and varistor leads (11) from load terminals (23).
- h. Remove terminal board assembly (12) from generator set.
- i. Remove load output terminals, paragraph 2-104-1.
- j. Remove EMI filter (24) positioned between LO and GND terminals (23).
- k. Remove varistor leads (11) from varistors (27).

- l. Remove varistors, paragraph 2-105-1.
- m. Remove EMI filters (28) positioned between load terminals (23) and varistors (27).
- n. Remove nuts (13), washers (14), ground strap (15), studs (16), bus bars (17) and (22), and ground plane bar (29) from terminal board (12).
- o. Remove nuts (18) and washers (19) from studs (16).
- p. Remove bolts (30), nuts (31), and load output terminal board supports (32) and (33) from generator set.
- q. Remove nuts (34), bolts (35), cord (36), wrench (37), and bracket (38) from support (33).

2-103-2 Inspection.

- a. Shut down generator set.
- b. Open load terminal board access door.
- c. Inspect load output terminal board for cracks, corrosion, and obvious damage.
- d. Inspect threaded components for stripped threads.
- e. Inspect varistor electrical leads for damaged insulation and loose terminals.
- f. Replace damaged and defective parts.
- g. Close load terminal board access door.

2-103-3 Repair.

Repair load output terminal board assembly by replacing damaged or defective wires, load terminals, EMI filters, and varistors.

2-103-4 Installation.

- a. Install load output terminal board supports (32 and 33, FIGURE 2-29) in generator set with bolts (30) and nuts (31).
- b. Install ground plane bar (29), bus bars (17) and (22), and ground strap (15) on terminal board (12) with studs (16), washers (14) and (19), and nuts (13) and (18).
- c. Position EMI filters (28) between varistors (27) and L1, L2, and L3 load terminals (23) mounting holes.
- d. Install varistors, paragraph 2-105-3.
- e. Position EMI filter (24) between LO and GND terminals (23) mounting holes.
- f. Install load terminals, paragraph 2-104-3.
- g. Connect leads (11) to varistors (27).
- h. Position load output terminal board assembly in generator set, and connect varistor leads (11) and main power leads (10) to load terminals (23) with washers (9) and nuts (8). Remove tags.
- i. Secure terminal board assembly to supports with washers (7), lockwashers (6), and bolts (5).
- j. Apply a thin coat of antiseize compound (Item 6, Appendix C) to skid at ground strap (15) attaching point.

- k. Install bolt (1), flatwasher (3), lockwasher (4), and nut (2) securing ground strap (15) to skid base.
- l. Install bracket (38), wrench (37), and cord (36) on support (33) with bolts (35) and nuts (34).
- m. Install generator set housing rear panel, paragraph 2-18-4.
- n. Connect load output cables L1, L2, L3, and L0 at load output terminal board and close load terminal access door.
- o. Connect negative battery cable. Close battery access door.

2-104 LOAD OUTPUT TERMINALS

2-104-1 REMOVAL.

- a. Shut down generator set.
- b. Open battery access door and disconnect negative battery cable.
- c. Open load terminal board access door and disconnect load cables.
- d. Remove load output terminal board assembly from generator set, paragraph 2-103-1.
- e. Remove nuts (20, FIGURE 2-29), copper washers (21), and load terminals (23) from terminal board assembly (12).

2-104-2 Inspection

- a. Shut down generator set.
- b. Open load terminal board access door.
- c. Inspect load terminals for stripped threads or other obvious damage.
- d. Replace damaged load terminals as necessary.
- e. Close load terminal board access door.

2-104-3 Installation.

- a. Install load output terminals (23, FIGURE 2-29) on load output terminal board assembly (12) with copper washers (21) and nuts (20).

NOTE

Ensure GND load terminal passes through ground plane bracket (29) and LO load terminal passes through bus bar (22).

- b. Install load output terminal board assembly in generator set, paragraph 2-103-4.
- c. Connect load cables and close load terminal board access door.
- d. Connect negative battery cable and close battery access door.

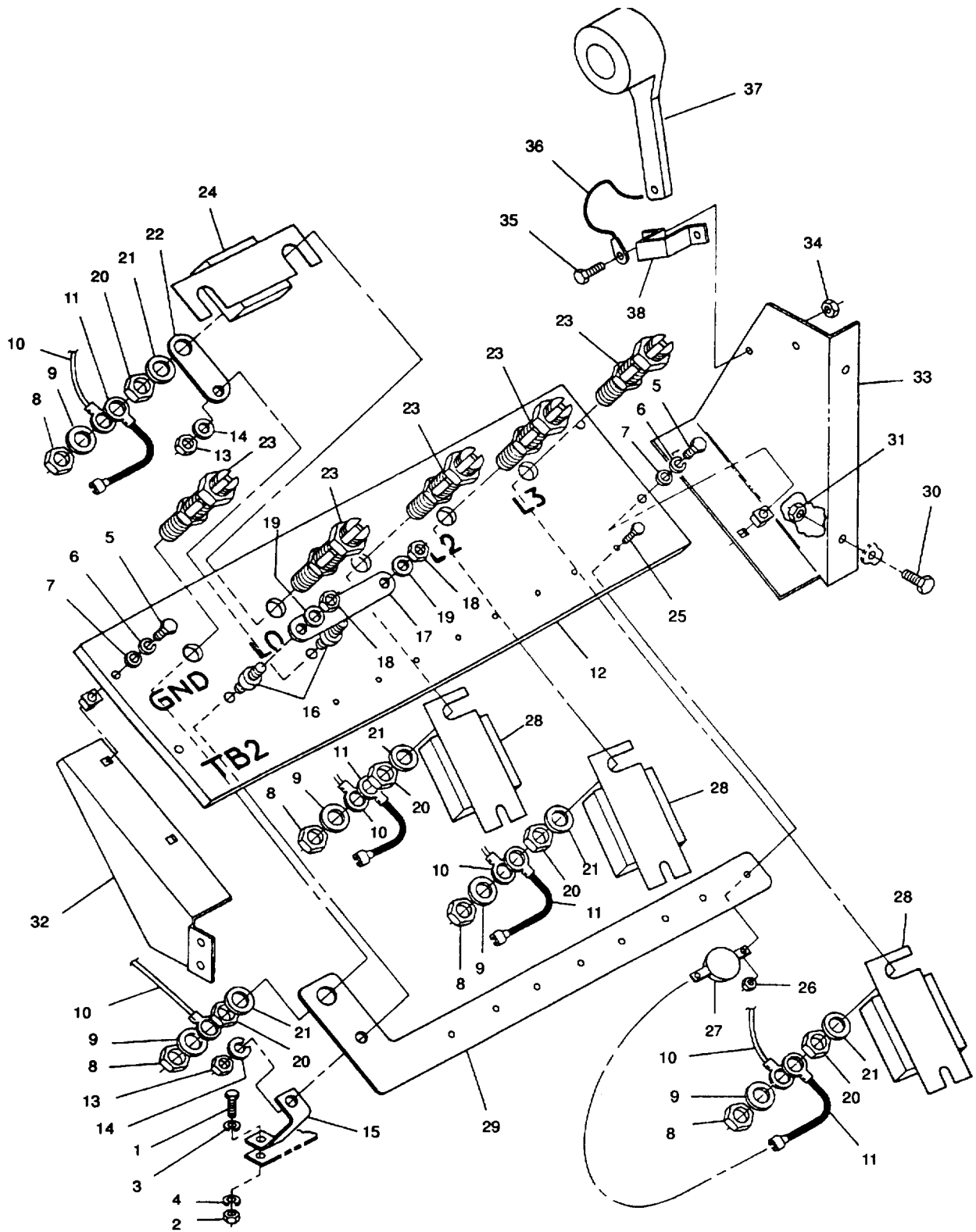

FIGURE 2-29. Load Terminal Board Assembly

2-105 VARISTORS.

2-105-1 Removal.

- a. Shut down generator set.
- b. Remove load output terminal board assembly from generator set, paragraph 2-103-1.
- c. Tag and disconnect varistor leads, (11, FIGURE 2-29) from varistors (27).
- d. Remove nuts (26), bolts (25), and varistors (27) from load terminal board assembly (12).

2-105-2 Inspection and Testing.

- a. Shut down generator set.
- b. Remove varistors, paragraph 2-105-1.
- c. Inspect varistors for obvious external damage.
- d. Set multimeter for ohms and test each varistor by connecting multimeter to varistor terminals 1 and 2. Note multimeter indication.
- e. Reverse multimeter leads and note multimeter indication.
- f. Multimeter indications should be infinite ohms in both directions.
- g. Varistors are defective and must be replaced if indications are other than above.
- h. Install varistors, paragraph 2-105-3.

2-105-3 Installation.

- a. Install varistors (27, FIGURE 2-29), on load output terminal board assembly (12) with bolts (25) and nuts (26).
- b. Connect varistor leads (11) to varistors (27) and remove tags.
- c. Install load output terminal board assembly in generator set, paragraph 2-103-4.

Section XV. MAINTENANCE OF ENGINE ACCESSORIES

2-106 LOW OIL PRESSURE SWITCH

2-106-1 Testing.

- a. Shut down generator set.
- b. Open battery access door and disconnect negative battery cable.
- c. Open left side engine access doors.
- d. Tag and disconnect electrical leads from low oil pressure switch (1, FIGURE 2-30).
- e. Set multimeter for ohms and connect across switch connector pins C and NO. Multimeter shall indicate open circuit.
- f. Connect multimeter across switch connector pins C and NC. Multimeter shall indicate continuity.
- g. Connect negative battery cable.

- h. Start the generator set. Place BATTLE SHORT switch in the ON position before releasing MASTER SWITCH from START position.
- i. Connect multimeter to switch connector pins C and NC. Multimeter shall indicate open circuit.
- j. Connect multimeter across switch connector pins C and NO. Multimeter shall indicate continuity.
- k. Shut down generator set. Return BATTLE SHORT switch to OFF position.
- l. Disconnect negative battery cable.
- m. If switch fails to meet continuity requirements, replace low oil pressure switch.
- n. If replacement is not needed, connect electrical leads to low oil pressure switch and remove tags.
- o. Close left side engine access doors.
- p. Connect negative battery cable and close battery access door.

2-106-2 Removal.

- a. Shut down generator set.
- b. Open battery access door and disconnect negative battery cable.
- c. Open left side engine access door, tag and disconnect low oil pressure switch (1, FIGURE 2-30) electrical leads.
- d. Unscrew low oil pressure switch (1) from oil sample valve assembly.

2-106-3 Cleaning and Inspection

- a. Shutdown generator set.
- b. Remove low oil pressure switch, paragraph 2-106-2.

WARNING

Dry cleaning solvent is flammable and toxic to eyes, skin, and respiratory tract. Skin/eye protection required. Avoid repeated/prolonged contact. Good general ventilation is normally adequate.

WARNING

Use low pressure air, 15 psi maximum. Wear protective glasses when using compressed air. Failure to follow this warning could result in severe personal injury.

- c. Clean low oil pressure switch with dry, filtered compressed air and wipe with a cleaning cloth (Item 8, Appendix C) lightly moistened with dry cleaning solvent (item 20, Appendix C).
- d. Inspect low oil pressure switch for cracked casing, stripped or damaged threads, corrosion, or other damage.
- e. If no repair is needed, install low oil pressure switch, paragraph 2-106-4.

2-106-4

- a. Install low oil pressure switch (1, FIGURE 2-30) into oil sample valve assembly.
- b. Connect electrical leads, remove tags and close left side engine access doors.

- c. Connect negative battery cable and close battery access door.

2-107 OIL PRESSURE SENDER.

2-107-1 Testing.

- a. Shut down generator set.
- b. Open battery access door and disconnect negative battery cable.
- c. Open left side engine access doors.
- d. Disconnect electrical lead to oil pressure sender (2, FIGURE 2-30).
- e. Set multimeter for ohms and connect between sender terminal and casing.
- f. Multimeter indication shall be between 216 and 264 ohms.
- g. Connect negative battery cable.
- h. Start generator set.
- i. As engine is cranking and accelerates to rated speed, observe multimeter. Indication shall decrease to between 100 and 33 ohms.
- j. Shut down generator set and disconnect negative battery cable.
- k. Replace oil pressure sender if indications are not as above.
- l. If replacement is not needed, connect electrical lead to oil pressure sender.
- m. Close left side engine access doors.
- n. Connect negative battery cable and close battery access door.

2-107-2 Removal.

- a. Shut down generator set.
- b. Open battery access door and disconnect negative battery cable.
- c. Open left side engine access door and disconnect oil pressure sender (2, FIGURE 2-30) electrical lead.
- d. Unscrew oil pressure sender (2) from engine block.

2-107-3 Cleaning and Inspection

- a. Shut down generator set.
- b. Remove oil pressure sender, paragraph 2-107-2.

WARNING

Dry cleaning solvent is flammable and toxic to eyes, skin, and respiratory tract. Skin/eye protection required. Avoid repeated/prolonged contact. Good general ventilation is normally adequate.

WARNING

Use low pressure air, 15 psi maximum. Wear protective glasses when using compressed air. Failure to follow this warning could result in severe personal injury.

- c. Clean oil pressure sender with dry, filtered compressed air and wipe with a cleaning cloth (Item 8, Appendix C) lightly moistened with dry cleaning solvent (Item 20, Appendix C).
- d. Inspect oil pressure sender for cracked casing, stripped or damaged threads, corrosion, or other visible damage.
- e. If no repair is needed, install oil pressure sender, paragraph 2-107-4.

2-107-4 Installation.

- a. Screw oil pressure sender (2, FIGURE 2-30) into engine block
- b. Conned electrical lead and dose left side engine access doors.
- c. Connect negative battery cable and dose battery access door.

2-108 COOLANT TEMPERATURE SENDER.

WARNING

Generator set exhaust manifold gets extremely hot. Use care when performing test on coolant temperature sender. Failure to observe this warning could result in severe burns.

2-108-1 Testing.

- a. Shut down generator set.
- b. Open battery access door and disconnect negative battery cable.
- c. Open left side engine access doors.
- d. Disconnect electrical lead from coolant temperature sender (4, FIGURE 2-30).
- e. Set multimeter for ohms and connect positive lead to temperature sander terminal and negative lead to case. Multimeter indication shall be greater than 300 ohms.
- f. Connect negative battery cable and start generator set.
- g. Allow the engine to operate while observing multimeter.
- h. Ohms indication should decrease as temperature rises.
- i. Shut down generator set and disconnect negative battery cable.

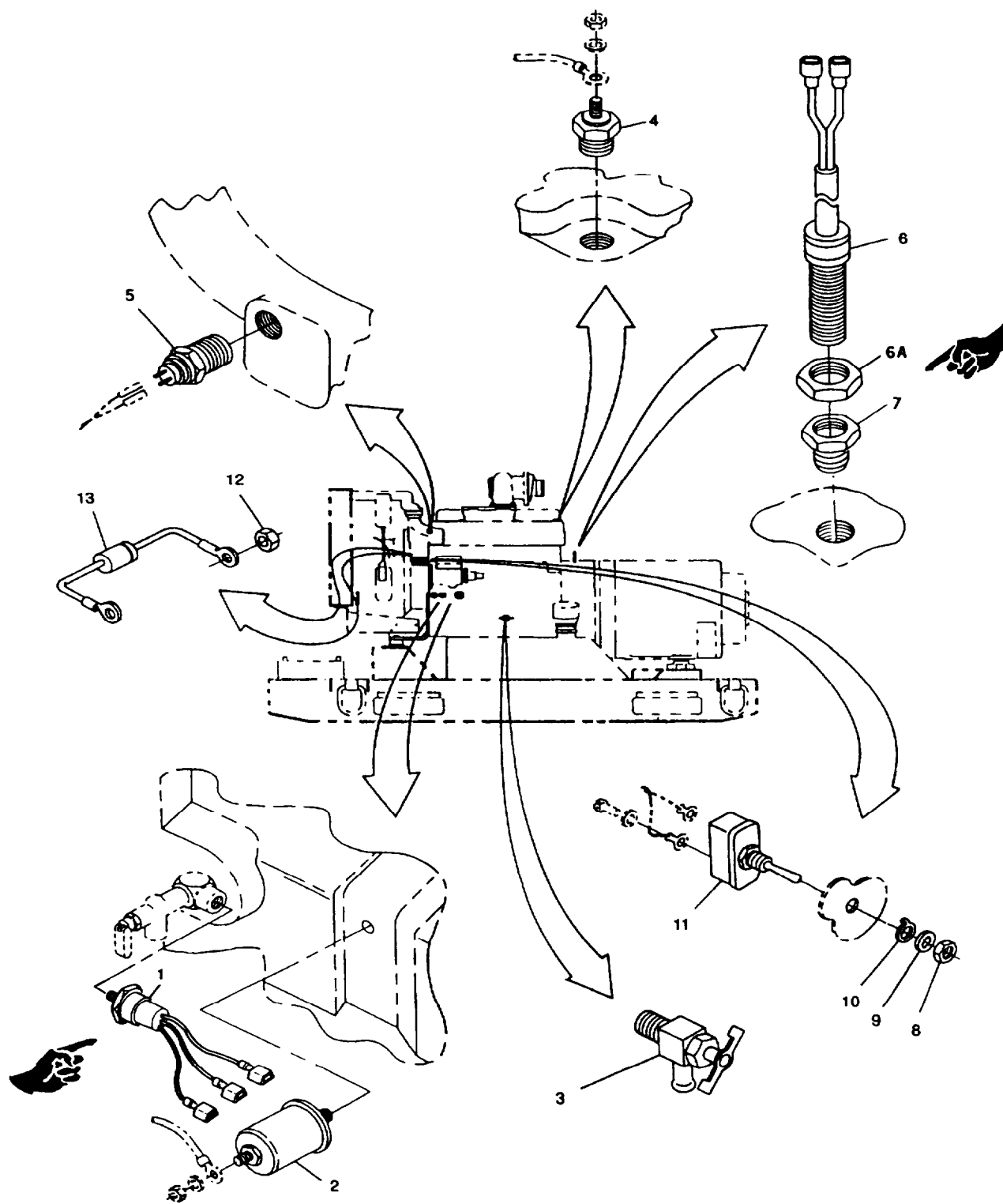

FIGURE 2-30. Engine Switches and Senders

- j. Replace coolant temperature sender if indications are not as above.
- k. If replacement is not needed, connect electrical lead to sender.
- l. Close left side engine access doors.
- m. Connect negative battery cable and close battery access door.

2-108-2 Removal.

- a. Shut down generator set.
- b. Open battery access door and disconnect negative battery cable.

WARNING

Coolant can get very hot. Allow system to cool down before performing maintenance. Failure to follow this warning could result in severe burns and injuries.

WARNING

Always remove radiator cap slowly to permit pressure to escape. Failure to follow this warning could result in severe personal injury.

- c. Slowly remove radiator cap (1, FIGURE 2-23).
- d. Open left side engine access doors, open engine block drain valve (3, FIGURE 2-30), and drain coolant into suitable container.
- e. Disconnect coolant temperature sender (4) electrical lead.
- f. Unscrew temperature sender (4) from engine head.

2-108-3 Cleaning and Inspection.

- a. Shut down generator set.
- b. Remove coolant temperature sender, paragraph 2-108-2.

WARNING

Dry cleaning solvent is flammable and toxic to eyes, skin, and respiratory tract. Skin/eye protection required. Avoid repeated/prolonged contact. Good general ventilation is normally adequate.

WARNING

Use low pressure air, 15 psi maximum. Wear protective glasses when using compressed air. Failure to follow this warning could result in severe personal injury.

- c. Clean temperature sender with dry, filtered compressed air and cleaning cloth (Item 8, Appendix C) lightly moistened with dry cleaning solvent (Item 20, Appendix C).
- d. Inspect temperature sender for cracked casing, corrosion, and damaged threads and connector.
- e. If no repair is needed, install coolant temperature sender, paragraph 2-108-4.

2-108-4 Installation.

- a. Install coolant temperature sender (4, FIGURE 2-30) in engine head.
- b. Connect electrical lead and close left side engine access doors.
- c. Connect negative battery cable and close battery access door.

2-109 COOLANT HIGH TEMPERATURE SWITCH.

2-109-1 Testing.

- a. Shut down generator set.
- b. Remove coolant high temperature switch, paragraph 2-109-2.
- c. Suspend high temperature switch in a container of 50/50 mixture of antifreeze and water so that sensing element is completely immersed but not touching sides or bottom of container.
- d. Suspend a reliable thermometer in container. Do not allow end of thermometer to rest on bottom of container.
- e. Set multimeter for ohms and check for continuity between switch terminals. Switch operates under open conditions.
- f. Gradually heat antifreeze/water mixture, stirring so that heat will be evenly distributed and observe thermometer and multimeter.
- g. At between 220 and 230°F (101 and 107°C) multimeter should indicate continuity.
- h. Replace high temperature switch if it fails to operate as above.
- i. If replacement is not needed, install coolant high temperature switch, paragraph 2-109-4.

2-109-2 Removal.

- a. Shut down generator set.
- b. Open battery access door and disconnect negative battery cable.

WARNING

Coolant can get very hot. Allow system to cool down before performing maintenance. Failure to follow this warning could result in severe burns and injuries.

WARNING

Always remove radiator cap slowly to permit pressure to escape. Failure to follow this warning could result in severe personal injury.

- c. Slowly remove radiator cap (1, FIGURE 2-23).
- d. Open left side engine access doors open engine block drain valve (3, FIGURE 2-30), and drain coolant into suitable container.
- e. Tag and disconnect coolant high temperature switch (5) electrical leads.
- f. Unscrew high temperature switch (5) from lower thermostat housing.

2-109-3 Cleaning and Inspection.

- a. Shut down generator set.
- b. Remove coolant high temperature switch, paragraph 2-109-2.

WARNING

Dry cleaning solvent is flammable and toxic to eyes, skin, and respiratory tract. Skin/eye protection required. Avoid repeated/prolonged contact. Good general ventilation is normally adequate.

WARNING

Use low pressure air, 15 psi maximum. Wear protective glasses when using compressed air. Failure to follow this warning could result in severe personal injury.

- c. Clean high temperature switch with dry, filtered compressed air and cleaning cloth (Item 8, Appendix C) lightly moistened with dry cleaning solvent (Item 20, Appendix C).
- d. Inspect high temperature switch for cracked casing, corrosion, stripped or damaged threads, and bent or broken connector pins.
- e. If no repair is needed, install coolant high temperature switch, paragraph 2-109-4.

2-109-4 Installation.

- a. Install coolant high temperature switch (5, FIGURE 2-30) in lower thermostat housing.
- b. Connect electrical leads, remove tags and close left side engine access doors.
- c. Connect negative battery cable and close battery access door.

2-110 MAGNETIC PICKUP.

2-110-1 Removal.

- a. Shut down generator set.
- b. Open battery access door and disconnect negative battery cable.
- c. Open left side engine access doors, tag and disconnect magnetic pickup (6, FIGURE 2-30) electrical leads.
- d. Loosen lock nut (6A) and remove magnetic pickup (6) and reducer bushing (7) from flywheel housing.

2-110-2 Cleaning and Inspection.

- a. Shut down generator set.
- b. Remove magnetic pickup, paragraph 2-110-1.

WARNING

Dry cleaning solvent is flammable and toxic to eyes, skin, and respiratory tract. Skin/eye protection required. Avoid repeated/prolonged contact. Good general ventilation is normally adequate.

WARNING

Use low pressure air, 15 psi maximum. Wear protective glasses when using compressed air. Failure to follow this warning could result in severe personal injury.

ARMY TM 9-6115-644-24
AIR FORCE TO 35C2-3-446-12
MARINE CORPS TM 09249A/09246A-24/2

- c. Clean magnetic pickup with dry filtered compressed air and wipe with a cleaning cloth (Item 8, Appendix C) lightly moistened with dry cleaning solvent (item 20, Appendix C).
- d. Inspect magnetic pickup for cracked casing, stripped or damaged threads corrosion, or other visible damage.
- e. If no repair is needed, install magnetic pickup, paragraph 2-110-3.

2-110-3 Installation.

- a. Install reducer bushing (7, FIGURE 2-30) into flywheel housing. Screw magnetic pickup (6) into reducer bushing (7) until contact is made with top surface of gear tooth on flywheel. Back magnetic pickup off one complete revolution. Tighten lock nut (6A).
- b. Connect electrical leads and remove tags.
- c. Connect negative battery cable. Close battery access door.
- d. Adjust magnetic pickup in accordance with paragraph 2-110-4.
- e. Close left side engine access doors.

2-110-4 Adjustment.

- a. Release control panel by turning two fasteners and lower control panel slowly.
- b. Disconnect wire 147C from terminal 16 and wire 148C from terminal 17 of governor control unit.
- c. Set multimeter for ohms and connect to ends of disconnected wires 147C and 148C. Multimeter should indicate between 800 and 1100 ohms.
- d. Leave multimeter connected to wires 147C and 148C and set multimeter for AC volts.
- e. Crank engine with DEAD CRANK switch and observe multimeter. Multimeter indication should be between 2.0 and 3.0 VAC.

CAUTION

Do not adjust magnetic pickup inward more than one eighth turn each time, or damage to magnetic pickup may result.

- f. To adjust output voltage in step e, loosen jam nut and turn magnetic pickup in no more than one-eighth turn at a time to increase output voltage, and out no more than one-eighth turn at a time to decrease output voltage. Tighten jam nut.
- g. Repeat steps e and f until proper output voltage is achieved.
- h. Remove multimeter, connect wires to governor control unit.
- i. Raise and secure control panel.

2-111 DEAD CRANK SWITCH.

2-111-1 Testing.

- a. Shut down generator set.
- b. Open battery access door and disconnect negative battery cable.
- c. Open left side engine access doors.
- d. Tag and disconnect electrical leads from DEAD CRANK switch (11, FIGURE 2-30).

- e. Set multimeter for ohms and with switch in NORMAL position, check for continuity between contacts 2 and 3.
- f. Move switch to CRANK position and check for continuity between contacts 1 and 2.
- g. If DEAD CRANK switch fails continuity checks, replace switch.
- h. If replacement is not needed, connect electrical leads to switch and remove tags.
- i. Close left side engine access doors.
- j. Connect negative battery cable and close battery access door.

2-111-2 Removal.

- a. Shut down generator set.
- b. Open battery access door and disconnect negative battery cable.
- c. Open left side engine access doors and remove nut (8, FIGURE 2-30), lockwasher (9), and tab washer (10).
- d. Remove DEAD CRANK switch (11) from governor actuator mounting plate.
- e. Tag and disconnect DEAD CRANK switch electrical leads.

2-111-3 Installation.

- a. Connect electrical leads to DEAD CRANK switch(11, FIGURE 2-30) and remove tags.
- b. Install DEAD CRANK switch (11) in governor actuator mounting plate with tab washer (10), lockwasher (9), and nut (8).
- c. Connect negative battery cable. Close battery access door and left side engine access doom.

2-112 DIOS ASSEMBLY.

2-112-1 Removal.

- a. Shut down generator set.
- b. Open battery access door and disconnect negative battery cable.
- c. Open left side engine access doors.
- d. Remove nuts (12, FIGURE 2-30) and diode assembly (13) from top of fuel injection pump.

2-112-2 Testing.

- a. Shut down generator set.
- b. Remove diode assembly, paragraph 2-112-1.
- c. Set multimeter for ohms and connect positive lead to terminal on banded side of diode assembly and negative lead to plain side. Note ohms indication on multimeter.
- d. Reverse multimeter leads on diode assembly. Note ohms indication on multimeter.
- e. Multimeter indication should be high in step c and low in step d.
- f. Diode assembly is defective and must be replaced if indications are other than above.
- g. If replacement is not needed, install diode assembly, paragraph 2-112-4.

2-112-3 Repair.

Repair diode assembly (13, FIGURE 2-30) by replacing damaged terminal ends.

2-112-4 Installation.

- a. Position diode assembly (13, FIGURE 2-30) on fuel injection pump with band end toward engine.
- b. Secure diode assembly (13) to fuel injection pump with nuts (12).
- c. Close left side engine access doors.
- d. Connect negative battery cable and close battery access door.

Section XVI. MAINTENANCE OF LUBRICATION SYSTEM

2-113 OIL DRAIN VALVE.

2-113-1 Inspection.

- a. Shut down generator set.
- b. Open battery and right side engine access doors.
- c. Inspect oil drain line for cracks, holes, loose or missing hardware, and other damage.
- d. Close battery and right side engine access doors.

2-113-2 Removal.

- a. Shut down generator set.
- b. Open battery access door and disconnect negative battery cable.
- c. Open right side engine access doors.
- d. Remove plug (1, FIGURE 2-31), open drain valve (2) and drain engine oil into suitable container.
- e. Loosen damp (3) and remove oil drain hoses from adapter (5).
- f. Remove drain valve (2) from skid fitting.
- g. Remove adapter (5) and pipe fitting (6) from oil drain valve (2).

2-113-3 Installation.

- a. Install adapter (5, FIGURE 2-31) and pipe fitting (6) in oil drain valve (2).
- b. Install drain valve (2) on skid fitting.
- c. Install oil drain hose on adapter (5). Secure with damp (3).
- d. Ensure drain valve (2) is closed, install plug (1) and service engine oil, paragraph 2-1-2-4.
- e. Check engine oil drain valve for leakage.
- f. Connect negative battery cable. Close battery and right side engine access doors.

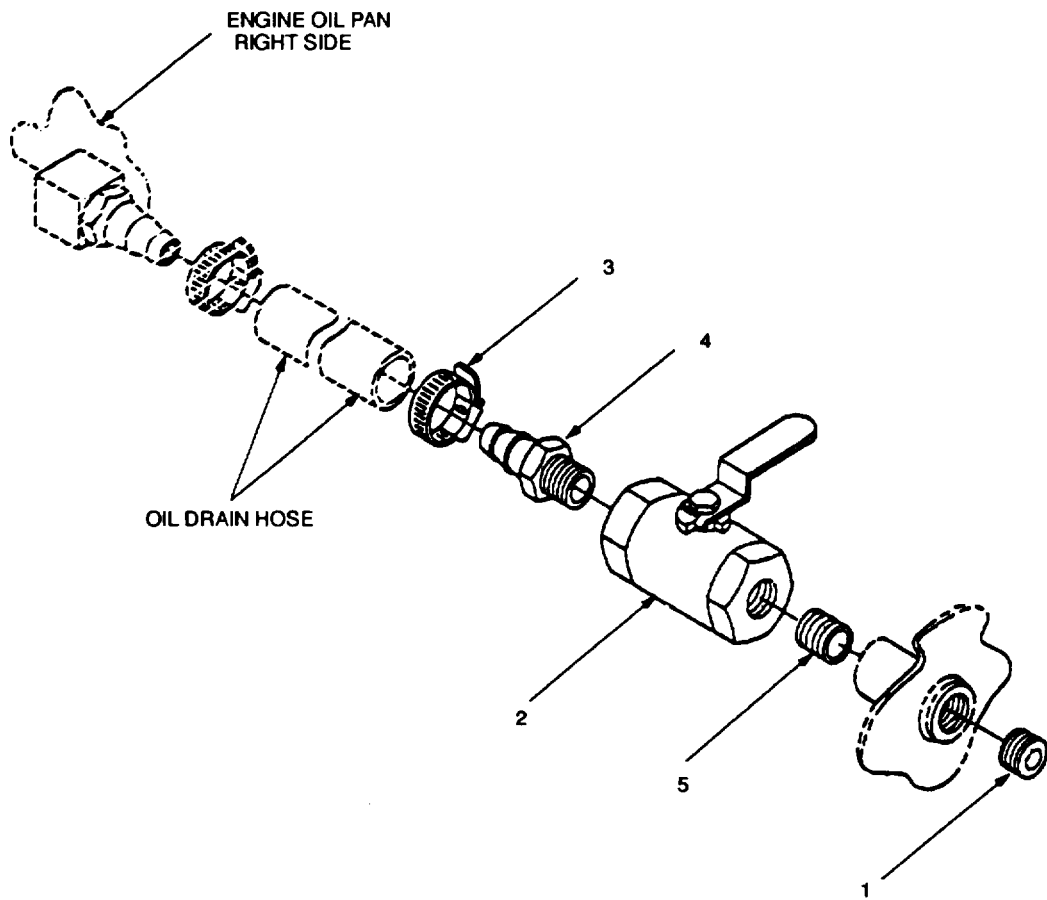

FIGURE 2-31. Oil Drain Valve

Section XVII. PREPARATION FOR SHIPMENT AND STORAGE

2-114 PRESERVATION.

Preserve generator sets in accordance with levels A, B, or C of MIL-G-28554.

Preserve generator set cooling systems in accordance with method II of MIL-G-28554 or the antifreeze and water procedure of MIL-E-10062.

2-115 PACKING.

Pack generator sets in accordance with levels A, B, or C of MIL-G-28554.

2-116 MARKING.

Mark for shipment or storage in accordance with MIL-STD-129.

2-117 USE OF CORROSION-PREVENTIVE COMPOUNDS.MOISTURE BARRIERS. AND DESICCANT MATERIALS.

(A) Refer to Corrosion and Corrosion Prevention/Metal, MIL-HDBK-729.

2-118 STORAGE.

(A) For storage information refer to TB 740-97-2. (F) Refer to TO 38-1-5.

CHAPTER 3

GENERAL MAINTENANCE INSTRUCTIONS

Section I. REPAIR PARTS; TOOLS; TEST, MEASUREMENT, AND DIAGNOSTIC EQUIPMENT (TMDE); AND SPECIAL SUPPORT EQUIPMENT

3-1 MAINTENANCE REPAIR PARTS.

Repair parts and equipment are listed and illustrated in the repair parts and special tools list manual TM 9-6115-644-24P.

3-2 TOOLS AND EQUIPMENT.

There are no special tools or support equipment required to perform any level of maintenance on the generator set. A list of recommended tools and support equipment required to maintain the generator set is contained in Appendix B, Section III.

3-3 FABRICATION OF TOOLS AND EQUIPMENT.

No requirement exists for fabrication of tools and equipment for maintenance of the generator set.

Section II. TROUBLESHOOTING

3-4 DIRECT SUPPORT TROUBLESHOOTING PROCEDURES.

3-4-1 Purpose of Troubleshooting Table. This section contains troubleshooting information for locating and correcting operating troubles which may develop in the generator set. Each malfunction for an individual component, unit, or system is followed by a list of tests or inspections which will help you to determine probable causes and corrective actions to take. You should perform the tests/inspections and corrective actions in the order listed.

This table cannot list all malfunctions that can occur, nor all test or inspections and corrective actions. If a malfunction is not listed or cannot be corrected by listed corrective actions, notify your supervisor.

NOTE

Before you use this table, be sure you have performed your PMCS.

NOTE

Before you use this table, be sure lower level troubleshooting steps have been performed.

NOTE

Refer to the Diagnostic Connector Table 2-9, Electrical Schematic FO-1 and Wiring Diagram FO-2 as troubleshooting aids.

SYMPTOM INDEX GENERATOR SET

	Troubleshooting Procedure Page
ENGINE	
Cranks but fails to start	3-3
Runs erratically or stalls frequently	3-3
Misfiring	3-4
Does not develop full power...	3-5
Coolant in crankcase	3-7
Abnormal noise	3-7
EXHAUST SYSTEM	
Black or grey smoke in exhaust.	3-6
Blue or white exhaust smoke.	3-6
GENERATOR SET	
Fails to generate power	3-8
Fails to generate sufficient voltage	3-8
Output fluctuates	3-9
Generator overheats	3-9
Generator noisy when running	3-10
LUBRICATION SYSTEM	
Low oil pressure	3-6
Highoil pressure	3-6

TABLE 3-1. Direct Support Troubleshooting

MALFUNCTION	TEST OR INSPECTION	CORRECTIVE ACTION
1. <u>ENGINE FAILS TO START.</u>		
Step 1.	Test fuel injection pump timing, refer to TM 9-2815-255-24.	a. If injection pump timing is correct, do step 2. b. If not correctly timed, time fuel injection pump in accordance with TM 9-2815-255-24.
Step 2.	Test for defective governor actuator, paragraph 4-15.	a. If governor actuator is not defective, do step 3. b. If defective, replace governor actuator, paragraph 4-15-2.
Step 3.	Test for defective fuel injection pump, refer to TM 9-2815-255-24.	a. If fuel injection pump is not defective, do step 4. b. If defective, repair or replace fuel injection pump in accordance with TM 9-2815-255-24.
Step 4.	Test for defective governor control unit, paragraph 4-3-2.	If defective, replace governor control unit, paragraph 4-3-4.
2. <u>ENGINE RUNS ERRATICALLY OR STALLS FREQUENTLY.</u>		
Step 1.	Test fuel injection pump timing, refer to TM 9-2815-255-24.	a. If fuel injection pump timing is correct, do step 2. b. If not correctly timed, time fuel injection pump in accordance with TM 9-2815-255-24.
Step 2.	Test for defective fuel injection pump, refer to TM 9-2815-255-24.	a. If fuel injection pump is not defective, do step 3. b. If defective, repair or replace fuel injector pump in accordance with TM 9-2815-255-24.
Step 3.	Check cylinder head gasket for leaks, refer to TM 9-2815-255-24.	a. If cylinder head gasket is not leaking, do step 4. b. If leaking, repair or replace cylinder head gasket in accordance with TM 9-2815-255-24.
Step 4.	Check valve adjustment, refer to TM 9-2815-255-24.	a. If valves are properly adjusted, do step 5. b. If improperly adjusted, adjust valves in accordance with TM 9-2815-255-24.

TABLE 3-1. Direct Support Troubleshooting - Continued

MALFUNCTION	TEST OR INSPECTION	CORRECTIVE ACTION
Step 5.	Check for stuck or burnt valves, refer to TM 9-2815-255-24.	a. If valves are not stuck or burnt, do step 6. b. If stuck or burnt, replace valves in accordance with TM 9-2815-255-24.
Step 6.	Test for defective governor control unit, paragraph 4-3-2.	a. If governor control unit is not defective, do step 7. b. If defective, replace governor control unit, paragraph 4-3-4.
Step 7.	Check for low engine compression, refer to TM 9-2815-255-24.	If compression is low, repair or replace engine in accordance with TM 9-2815-255-24.
3. <u>ENGINE MISFIRING.</u>		
Step 1.	Check for defective fuel injection nozzles, refer to TM 9-2815-255-24.	a. If fuel injection nozzles are not defective, do step 2. b. If defective, replace fuel injection nozzles, refer to TM 9-2815-255-24.
Step 2.	Test for defective governor actuator, refer to paragraph 4-15.	a. If governor is not defective, do step 3. b. If defective, replace governor in accordance with TM 9-2815-255-24.
Step 3.	Test fuel injection pump timing, refer to TM 9-2815-255-24.	a. If fuel injection pump timing is correct, do step 4. b. If timing is not correct, time fuel injection pump in accordance with TM 9-2815-255-24.
Step 4.	Test for defective fuel injection pump, refer to TM 9-2815-255-24.	a. If fuel injection pump is not defective, do step 5. b. If defective, repair or replace fuel injection pump in accordance with TM 9-2815-255-24.
Step 5.	Check valve adjustment, refer to TM 9-2815-255-24.	a. If valves are properly adjusted, do step 6. b. If improperly adjusted, adjust valve in accordance with TM 9-2815-255-24.
Step 6.	Check for weak valve springs, refer to TM 9-2815-255-24.	a. If valve springs are not weak, do step 7. b. If weak, replace valve springs in accordance with TM 9-2815-255-24.

TABLE 3-1. Direct Support Troubleshooting - Continued

MALFUNCTION	TEST OR INSPECTION	CORRECTIVE ACTION
step 7.	Check for stuck or burnt valves, refer to TM 9-2815-255-24.	<ul style="list-style-type: none"> a. If valves are not stuck or burnt, do step 8. b. If stuck or burnt, replace valves in accordance with TM 9-2815-255-24.
Step 8.	Test for low engine compression, refer to TM 9-2815-255-24.	If compression is low, repair or replace engine in accordance with TM 9-2815-255-24.
4. <u>ENGINE DOES NOT DEVELOPE FULL POWER</u>		
Step1.	Check for defective fuel injection nozzles, refer to TM 9-2815-255-24.	<ul style="list-style-type: none"> a. If fuel injection nozzles are not defective, do step 2. b. If defective, replace fuel injection nozzles, refer to TM9-2815-255-24.
step 2.	Test for defective governor, refer to paragraph 4-15.	<ul style="list-style-type: none"> a. If governor is not defective, do step 3. b. If defective, replace governor in accordance with paragraph 4-15-3.
step 3.	Test for defective governor control unit, pararaph 4-3-2.	<ul style="list-style-type: none"> a. If governor control unit is not defective, do step 4. b. If defective, replace governor control unit, pararaph 4-3-2.
Step 4.	Test fuel injection pump timing, refer to TM 9-2815-255-24.	<ul style="list-style-type: none"> a. If fuel injection pump timing is correct, do step 5. b. If timing is not correct, time fuel injection pump in accordance with TM 9-2815-255-24.
Step 5.	Check valve adjustment, refer toTM9-2815-255-24.	<ul style="list-style-type: none"> a. If valves are properly adjusted, do step 6. b. If improperly adjusted, adjust valves, refer toTM9-2815-255-24.
Step 6.	Test for defective cylinder head gasket, refer to TM 9-2815-255-24.	<ul style="list-style-type: none"> a. If cylinder head gasket is not defective, do step 7. b. If defective, replace cylinder head gasket in accordance with TM 9-2815-255-24.
step 7.	Check for weak valve springs, refer to TM 9-2815-255-24.	<ul style="list-style-type: none"> a. If valve springs are not weak do step 8. b. If weak, replace valve springs in accordance with TM 9-2815-255-24.
Step 8.	Check for stuck or burnt valves, refer to TM 9-2815-255-24.	<ul style="list-style-type: none"> a. If valves are not stuck or burnt, do step 9. b. If stuck or burnt, replace valves in accordance with TM 9-2815-255-24.

TABLE 2-1. Direct Support Troubleshooting - Continued

MIALFUNCTION	TEST OR INSPECTION	CORRECTIVE ACTION
Step 9.	Test for low engine compression, refer to TM 9-2815-255-24.	If compression is low, repair or replace engine in accordance with TM 9-2815-255-24.
<u>5. BLACK OR GRAY SMOKE IN EXHAUST.</u>		
Step 1.	Check for defective fuel injection nozzles, refer to TM 9-2815-255-24.	
	a. If fuel injection nozzles are not defective, do step 2.	
	b. If defective, replace fuel injection nozzles, refer to TM 9-2815-255-24.	
Step 2.	Test fuel injection pump timing, refer to TM 9-2815-255-24.	
	If timing is not correct, time fuel injection pump in accordance with TM 9-2815-255-24.	
<u>6. BLUE OR WHITE EXHAUST SMOKE.</u>		
	Test fuel injection pump timing, refer to TM 9-2815-255-24.	
	If timing is not correct, time fuel injection pump in accordance with TM 9-2815-255-24.	
<u>7. LOW OIL PRESSURE.</u>		
Step 1.	Check for defective regulating valve, refer to TM 9-2815-255-24,	
	a. If regulating valve is not defective, do step 2.	
	b. If defective, replace regulating valve in accordance with TM 9-2815-255-24.	
Step 2.	Check for defective oil pump, refer to TM 9-2815-255-24.	
	a. If oil pump is not defective, repair or replace engine.	
	b. If oil pump is defective, replace oil pump in accordance with TM 9-2815-255-24.	
<u>8. HIGH OIL PRESSURE.</u>		
	Test for defective oil filter relief valve, refer to TM 9-2815-255-24.	
	If defective, replace oil filter relief valve in accordance with TM 9-2815-255-24.	

TABLE 3-1. Direct Support Troubleshooting - Continued

MALFUNCTION	TEST OR INSPECTION	CORRECTIVE ACTION
9. <u>COOLANT IN CRANKCASE OR OIL IN COOLANT.</u>		
step 1.	Check for cracked cylinder head or block, refer to TM 9-2815-255-24.	a. If cylinder head or block is not cracked, do step 2. b. If cracked, replace cylinder head or block in accordance with TM 9-2815-255-24.
Step 2.	Check for defective cylinder head gasket, refer to TM 9-2815-255-24.	If defective, replace cylinder head gasket in accordance with TM 9-2815-255-24.
10. <u>ABNORMAL ENGINE NOISE.</u>		
Step 1.	Check for defective engine mounts.	a. If engine mounts are not defective, do step 2. b. If engine mounts are defective, replace mounts, paragraph 3-7.
Step 2.	Check valve adjustment, refer to TM 9-2815-255-24.	a. If valves are properly adjusted, do step 3. b. If improperly adjusted, adjust valves, refer to TM 9-2815-255-24.
Step 3.	Check for worn rocker arm shafts, refer to TM 9-2815-255-24.	a. If rocker arm shafts are not worn, do step 4. b. If worn, replace rocker arms in accordance with TM 9-2815-255-24.
Step 4.	Check for bent push rods, refer to TM 9-2815-255-24.	a. If push rods are not bent, do step 5. b. If bent, replace push rods in accordance with TM 9-2815-255-24.
Step 5.	Check for worn idler gears, refer to TM 9-2815-255-24.	a. If idler gears are not worn, do step 6. b. If worn, replace idler gears in accordance with TM 9-2815-255-24.
Step 6.	Check for foreign material in combustion chamber, refer to TM 9-2815-255-24.	a. If foreign material is found, clean combustion chamber in accordance with TM 9-2815-255-24. b. If no foreign material is found, and problem persists, replace engine, refer to TM 9-2815-255-24.

TABLE 3-1. Direct Support Troubleshooting - Continued

MALFUNCTION	TEST OR INSPECTION	CORRECTIVE ACTION
11. GENETATOR SET FAILS TO GENERATE POWER.		
Step 1.	Test for defective governor control unit, paragraph 4-3-2.	a. If governor control unit is not defective, do step 2. b. If defective, replace governor control unit, paragraph 4-3-4.
Step 2.	Test for defective AC voltage regulator.	a. If voltage regulator is not defective, do step 3. b. If defective, replace AC voltage regulator, paragraph 4-1.
Step 3.	Test for defective generator exciter stator, paragraph 4-21-1.	a. If exciter stator is not defective, do step 4. b. If defective, replace exciter stator, paragraph 4-21.
Step 4.	Test for defective generator stator, paragraph 4-24-1.	a. If generator stator is not defective, do step 5. b. If defective, replace generator stator and housing assembly, paragraph 4-24.
Step 5.	Test for defective diode(s) in generator rotating rectifier, paragraph 4-18-1.	a. If diodes are not defective, do step 6. b. If defective, replace diode(s), paragraph 4-18.
Step 6.	Test for defective generator rotor, paragraph 4-23-1.	a. If generator rotor is not defective, do step 7. b. If defective, replace generator rotor assembly, paragraph 4-23.
Step 7.	Test for defective generator exciter rotor, paragraph 4-22.	If defective, replace generator rotor assembly, paragraph 4-23.
12. GENERATOR SET FAILS TO GENERATE SUFFICIENT VOLTAGE.		
Step 1.	Check for low engine speed, refer to TM 9-2815-255-24.	a. If engine is operating correctly, do step 2. b. If engine is not operating correctly, repair in accordance with TM 9-2815-255-24
Step 2.	Test for defective power potential transformer, paragraph 4-13.	a. If power potential transformer is not defective, do step 3. b. If defective, replace power potential transformer, paragraph 4-13-1.

TABLE 3-1. Direct Support Troubleshooting - Continued

MALFUNCTION	TEST OR INSPECTION	CORRECTIVE ACTION
Step 3.	Test for defective AC voltage regulator.	a. If voltage regulator is not defective, do step 4. b. If defective, replace AC voltage regulator, paragraph 4-1.
Step 4.	Test for defective generator stator, paragraph 4-24-1.	If defective, replace generator stator and housing assembly, paragraph 4-24.
13. GENERATOR SET OUTPUT FLUCUATES.		
Step 1.	Check for irregular engine speed, refer to TM 9-2815-255-24.	a. If engine is operating correctly, do step 2. b. If engine is not operating correctly, repair in accordance with TM 9-2815-255-24.
Step 2.	Check for loose terminations or refer to FO-1.	a. If terminations are tight, do step 3. b. If loose, tighten terminals.
Step 3.	Test for defective AC voltage regulator.	a. If voltage regulator is not defective, do step 4. b. If defective, replace AC voltage regulator, paragraph 4-1.
Step 4.	Test for intermediate short in generator exciter field, paragraph 4-21-1.	If shorted, replace exciter stator, paragraph 4-21.
14. <u>GENERATOR OVERHEATS.</u>		
Step 1.	Check for dogged air intake screens.	a. If air intake screens are not dogged, do step 2. b. If dogged, dean air intake screens.
Step 2.	Check for defective fan, paragraph 4-23.	a. If fan is not defective, do step 3. b. If defective, replace fan, paragraph 4-23-3.
Step 3.	Check for dry generator main bearing, paragraph 4-19.	If dry, replace main bearing, paragraph 4-19.

TABLE 3-1. Direct Support Troubleshooting - Continued

MALFUNCTION	TEST OR INSPECTION	CORRECTIVE ACTION
15. <u>GENERATOR NOISY WHEN RUNNING.</u>		
Step 1.	Check for defective generator main bearing, paragraph 4-19.	a. If generator main bearing is not defective, do step 2. b. If defective, replace main bearing, paragraph 4-19.
Step 2.	Check for loose engine/generator coupling, paragraph 3-7-2, step j.	a. If engine/generator coupling is not loose, do step 3. b. If loose, tighten engine/generator coupling bolts, paragraph 3-7-2.
Step 3.	Test for defective generator.	If defective, replace generator, paragraph 4-17.

Section III. REMOVAL AND INSTALLATION OF MAJOR COMPONENTS.

3-5 GENERAL

The engine and generator are bolted together at the engine flywheel and flywheel housing adapter. The engine and generator may be removed as an assembly or separately. The engine and generator assembly is mounted on the skid base at four points. There are also brackets installed on both sides of the engine to support rear of engine when removing generator separately.

3-6 ENGINE AND GENERATOR ASSEMBLY.

3-6-1 Removal.

- a. Shut down generator set.
- b. Open battery access door and disconnect negative battery cable.
- c. Remove output box assembly and generator set housing, paragraphs 4-8-1, 2-17-1 and 2-18-1.
- d. Remove radiator, paragraph 2-82-1.
- e. Drain engine oil and disconnect oil drain line at engine fitting, paragraph 2-113-2.
- f. Disconnect fuel line at engine fuel pump from fuel pickup, paragraph 2-86-1.
- g. Disconnect engine excess fuel return line at tank fitting, paragraph 2-86-1.
- h. Disconnect coolant overflow hose from overflow bottle, paragraph 2-81-1.

- i. Remove nuts (1, FIGURE 3-1) washers (2), snubbing washers (3), washers (37), and bolts (4) from engine mounts (5).
- j. Remove rear fork lift guide from generator set, paragraph 4-25-1.
- k. Remove nuts (6), washers (7), bolts (8), snubbing washers (9) and Belleville washers (10) from generator mounts.
- l. Tie wrap generator power leads and secure out of the way.

CAUTION

Rated capacity of overhead hoist should be at least 2000 lbs (907 kg). Arrange lifting device so that it supports both engine and generator to avoid undue stress on the engine and generator coupling.

- m. Attach lifting harness to engine and generator lifting points. Raise engine and generator assembly from skid base.
- n. Move engine and generator assembly to maintenance work area. Support assembly on maintenance stand or fixture.
- o. Remove engine shock mounts (14) from skid base by removing nuts (11), washers (12) and bolts (13).
- p. Remove shock mounts (15) from generator mounting points on skid base.
- q. Remove engine mounting brackets (5) by removing bolts (16), lockwashers (17,) and washers (18).
- r. Remove engine support brackets (22) by removing bolts (19), lockwashers (20), and washers (21).
- s. Remove generator mount angles (29), plates (28), nuts (23) and (27), washers (24) and (26) and bolts (25) from generator.

3-6-2 Installation.

- a. Install engine shock mounts (14, FIGURE 3-1) on skid base with bolts (13) washers (12), and nuts (11).
- b. Position generator shock mounts (15) in skid base.
- c. Install engine mounting brackets (5) on engine with bolts (16), lockwashers (17), and washers (18). Torque bolts (16) to 120 ft-lbs (162.6 Nm).
- d. Install engine support brackets (22) on engine with bolts (19), lockwashers (20), and washers (21).
- e. Install generator mount angles (29) and plates (28) on generator with bolts (25), washers (24) and (26), and nuts (23) and (27).

CAUTION

Rated capacity of overhead hoist should be at least 2,000 lbs (907 kg). Arrange lifting device so that it supports both engine and generator to avoid undue stress on the engine and generator coupling.

- f. Attach lifting harness to engine and generator lifting points. Raise engine and generator assembly from maintenance stand or fixture.
- g. Position engine and generator assembly on skid base aligning mounting holes and brackets

ARMY TM 9-6115-644-24
AIR FORCE TO 35C2-3-446-12
MARINE CORPS TM 09249A/09246A-24/1

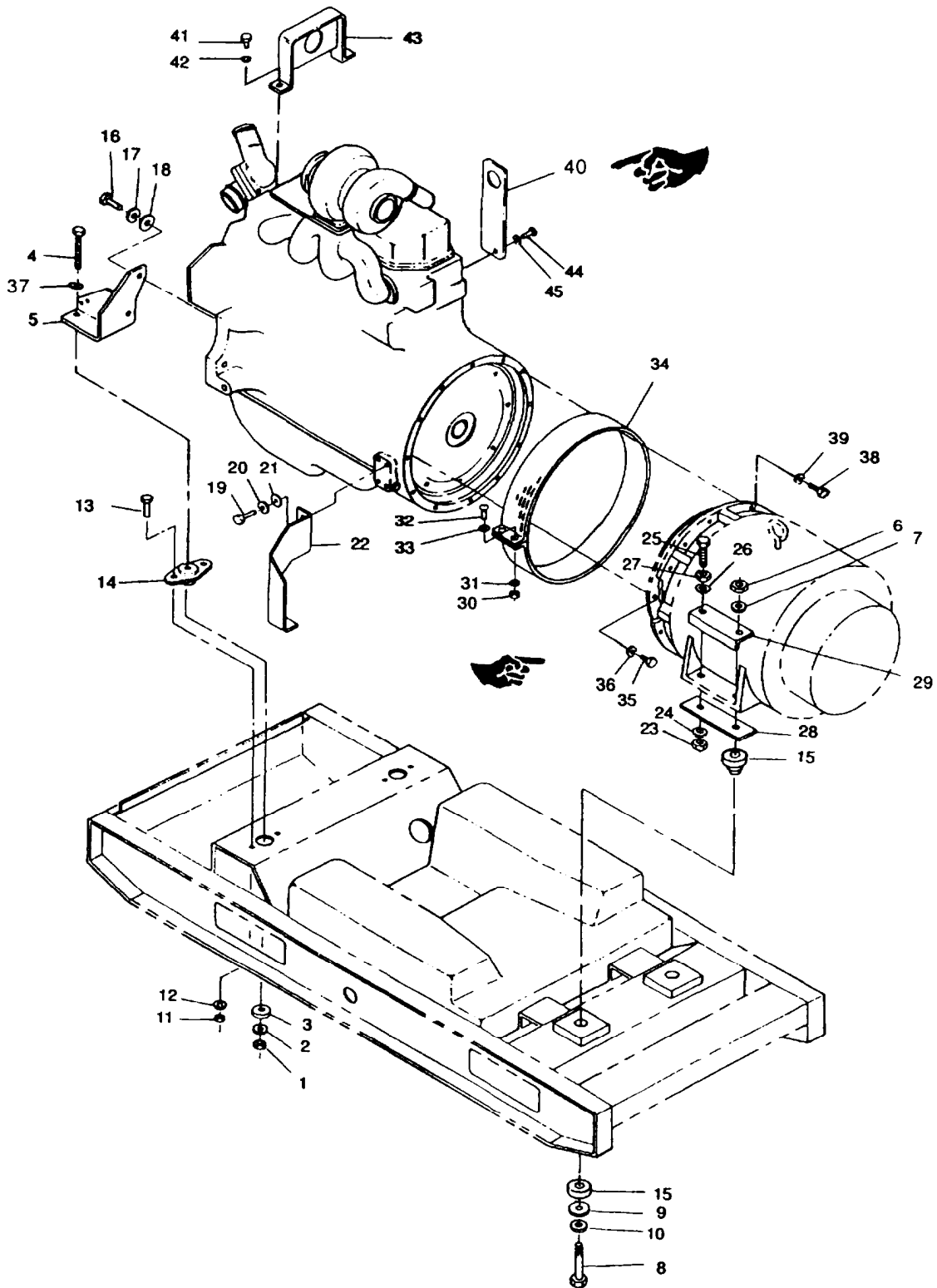

FIGURE 3-1. Engine and Generator Assembly

- h. Install bolts (8), Belleville washers (10), snubbing washers (9), washers (7), and nuts (6) to secure generator to skid base. Torque bolts (8) to 210 ft-lbs (284.7 Nm).
- i. Adjust nuts (23) and (27) to obtain 0.5 in. minimum clearance between ends of bolts (25) and skid base.
- j. Install bolts (4), washers (37), snubbing washers (3), washers (2), and nuts (1) to secure engine to skid base. Torque bolts (4) to 75 ft-lbs (101.7 Nm).
- k. Install rear forklift guide in skid base, paragraph 4-25-3.
- l. Connect oil drain line to engine fitting, paragraph 2-113-3.
- m. Connect coolant overflow hose to overflow bottle, paragraph 2-81-3.
- n. Install radiator, paragraph 2-82-4.
- o. Connect fuel line to engine fuel pump from fuel pickup, paragraph 2-86-2.
- p. Connect engine excess fuel return line at tank fitting, paragraph 2-86-2.
- q. Install output box assembly and generator set housing, paragraphs 4-8-2, 2-17-4 and 2-18-4.
- r. Service engine lubrication system, paragraph 2-1-2-4.
- s. Service coolant system, paragraph 2-1-2-2.
- t. Connect negative battery cable. Close battery access door.
- u. Start generator set. Perform operational checks and check for leaks.

3-7 ENGINE ASSEMBLY.

3-7-1 Removal.

- a. Shut down generator set.
- b. Open battery access door and disconnect negative battery cable.
- c. Using a suitable container, drain engine oil.

WARNING

Allow system to cool down. Remove radiator cap slowly to permit pressure to escape. Failure to follow these instructions could result in severe burns and injuries.

- d. Using a suitable container, drain engine coolant from radiator and engine block.
- e. Remove control box assembly, paragraph
- f. Remove bolts (1 and 4, FIGURE 3-2) lockwashers (2) and (5), washers (3), and (6), and top housing panel (7) from generator set.
- g. Loosen clamp (1, FIGURE 3-3) at radiator (2).
- h. Loosen clamp (3) and disconnect overflow hose (4) from filler hose and panel assembly (5).
- i. Remove filler hose and panel assembly (5) from generator set.

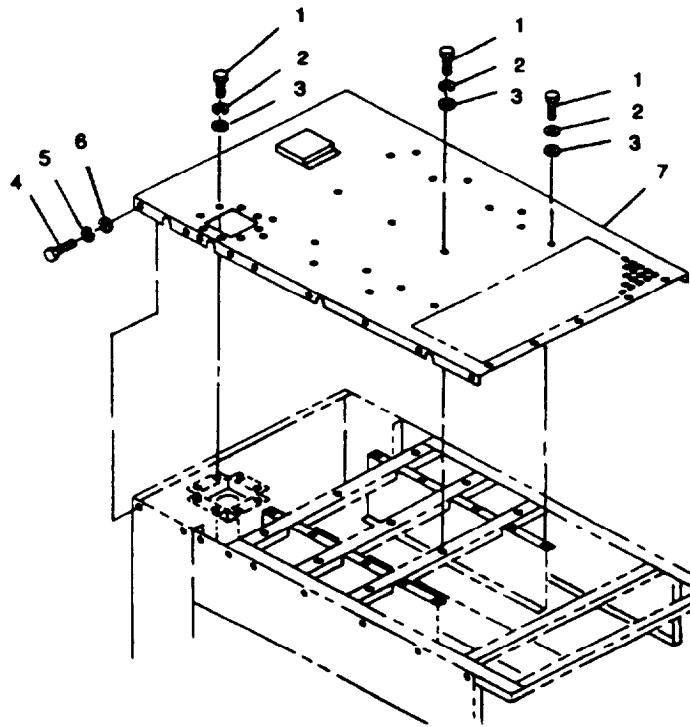

FIGURE 3-2. Top Housing Panel

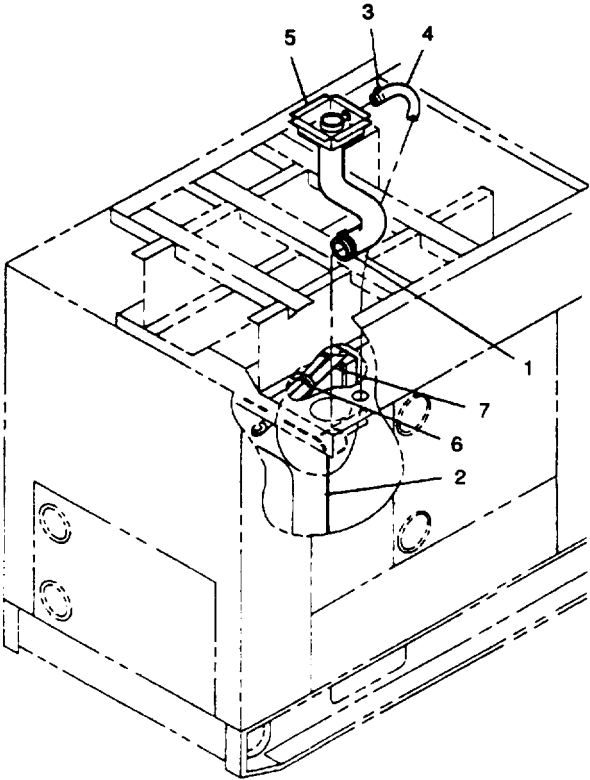

FIGURE 3-3. Filler Hose and Panel Assembly

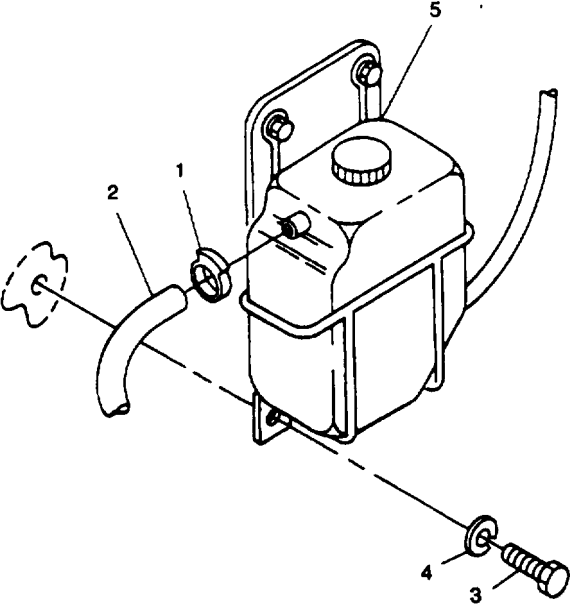

FIGURE 3-4. Overflow Bottle Assembly

- j. Cut wire ties (6) securing overflow hose (4) to upper radiator supports (7).
- k. Remove damp (1, FIGURE 3-4) and disconnect hose (2) from overflow bottle assembly (5).
- l. Remove bolts (3), lockwashers (4), and overflow bottle assembly (5) from right side of engine.
- m. Remove exhaust pipe clamp (1, FIGURE 3-5) at turbocharger outlet.
- n. Remove nuts (2), lookwashers (3), flat washers (5) and bolts (4) securing top housing section (10) to front housing.
- o. Remove assembled nuts (6) and bolts (7) securing top housing section (10) to rear side panels.
- p. Remove assembled nut (8) and bolt (9) securing top housing section (10) to output box angle.
- q. Using a lifting device, remove top housing section assembly (10) from generator set.
- r. Remove fan guards, refer to paragraph 2-78-2.
- s. Remove bolts (1, FIGURE 3.6), washers (3), lookwashers (2), and shroud(4) from radiator assembly (23). Allow shroud (4) to lay on fan (7).
- t. Remove bolts (5), lockwashers (6), fan (7), spacer (6), and shroud (4).
- u. Remove nuts (9), lookwashers (10), bolts (11), and washers (12) securing support rods (13) to engine lifting bracket.
- v. Loosen damp (14) at thermostat housing and disconnect hose (15).
- w. Loosen clamp(16) at water pump and disconnect hose (17).
- x. Loosen clamp (18) and disconnect hose (19) from radiator drain valve (20).

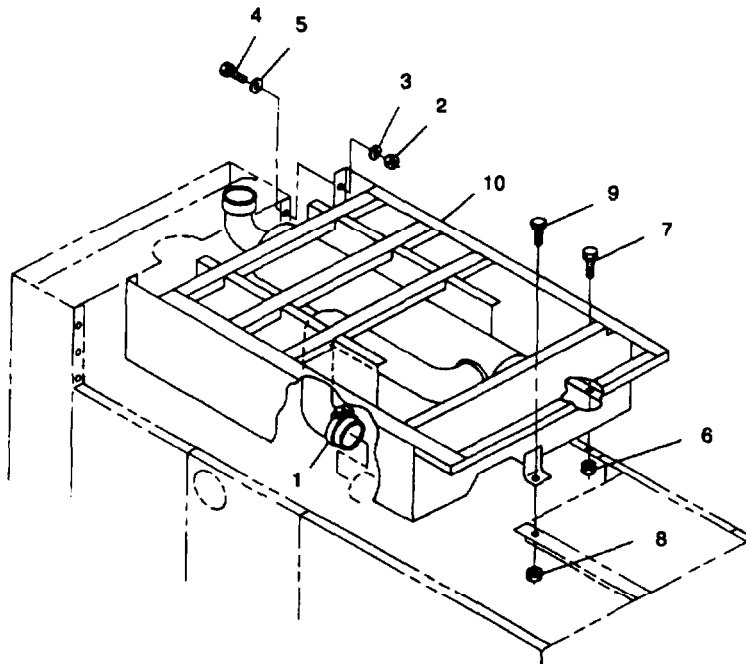

FIGURE 3-5. Top Housing Section Assembly

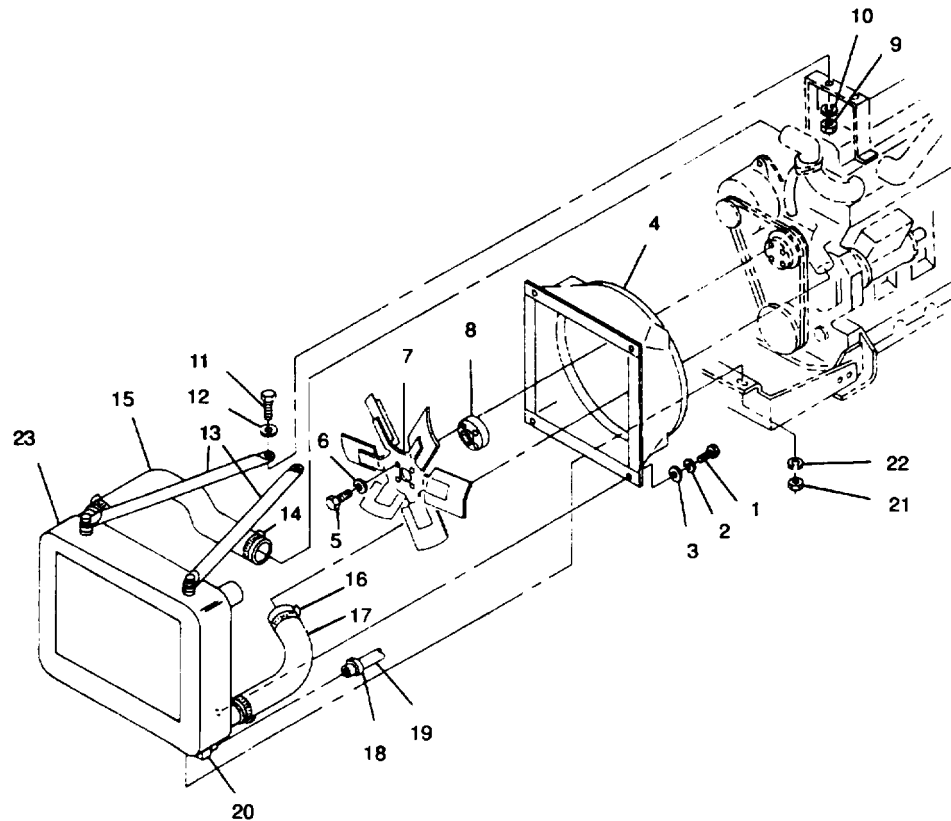

FIGURE 3-6. Radiator Assembly

- y. Remove nuts (21) and lockwashers (22) securing radiator assembly (23). With the aid of an assistant, remove radiator assembly (23).
- z. Remove bolts (1 and 4, FIGURE 3-7), washers (3) and (5), lockwashers (2) and (6), nuts (7), and rear housing panel (8) from generator set.
- aa. Loosen damp (1, FIGURE 3-8) securing hose (2) to fuel tank. Cap openings.
- ab. Loosen damp (3) and disconnect hose (4) from fuel filler panel assembly (5). Cap openings.
- ac. Disconnect fuel line (6) from hose (7). Cap openings.
- ad. Tag and disconnect auxiliary fuel pump (8) and fuel float switch module (9) electrical connectors.
- ae. Remove bolts (1, FIGURE 3-9), lockwashers (2), and washers (3) securing left rear side panel (4) to skid base.
- af. Remove nuts (8), lockwashers (6) and (9), washers (7) and (11), and bolts (5) and (10) securing lower left side panel (12) to front housing and skid base. With aid of an assistant, remove left rear side panel (4) and lower left side panel (12) as an assembly.
- ag. Loosen damp (1, FIGURE 3-10) securing tube (2) to hose (3) and hump hose (4) to turbocharger.

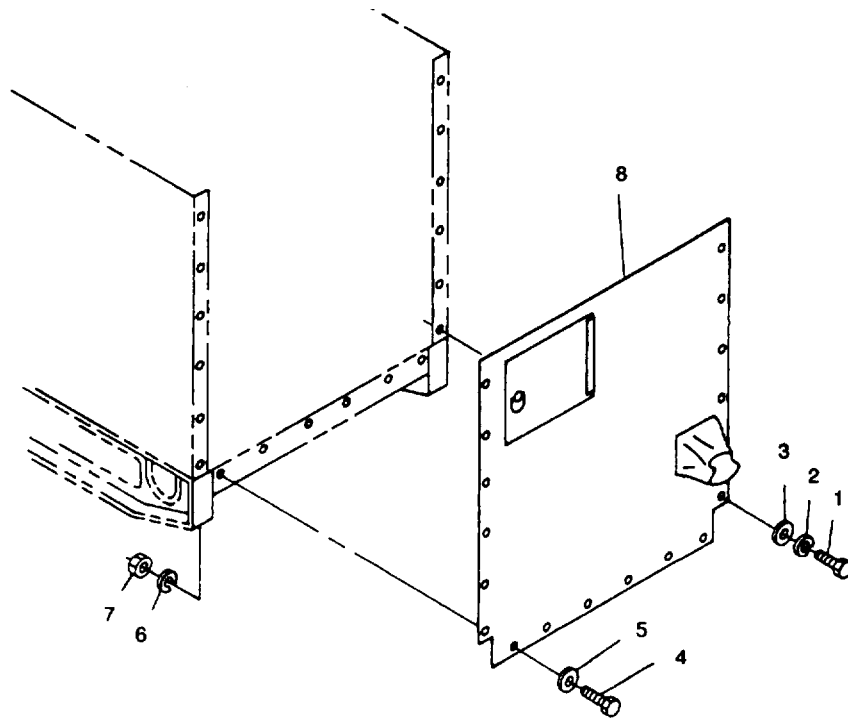

FIGURE 3-7. Rear Housing Panel

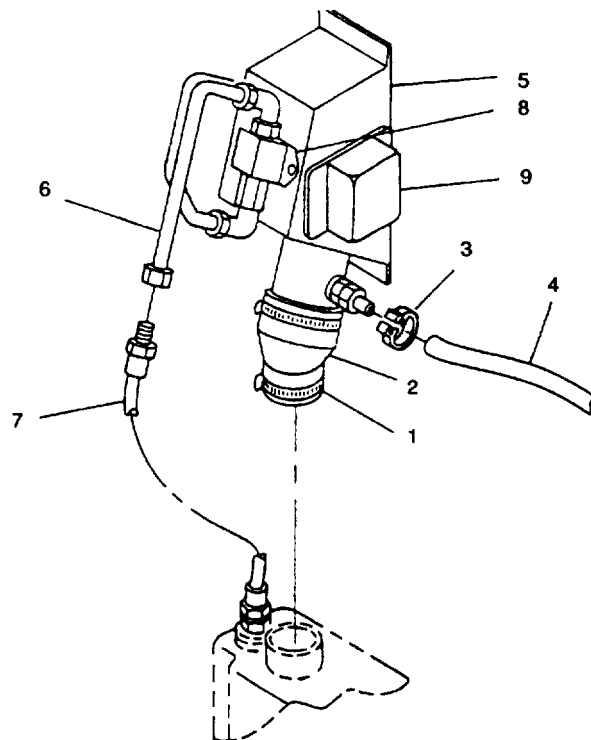

FIGURE 3-8. Fuel Filler Hoses and Panel Assembly

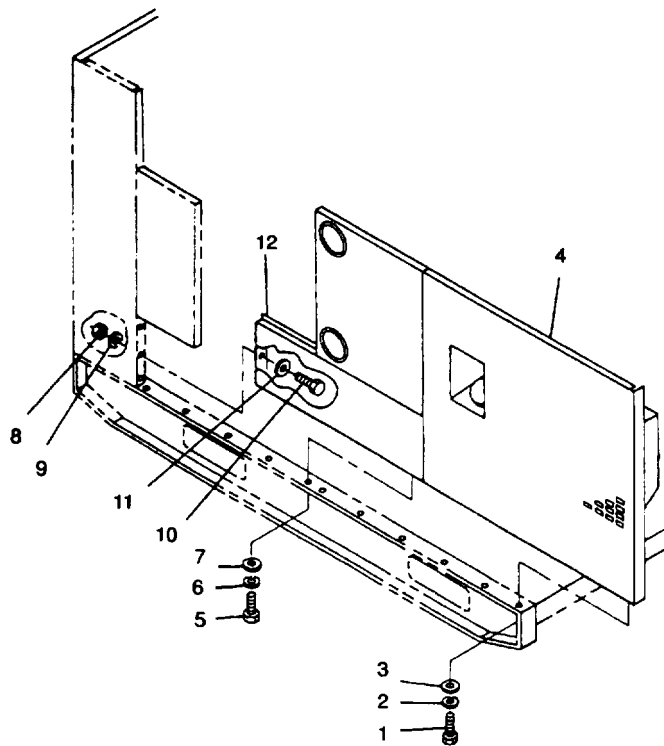

FIGURE 3-9. Left Side Housing Panels

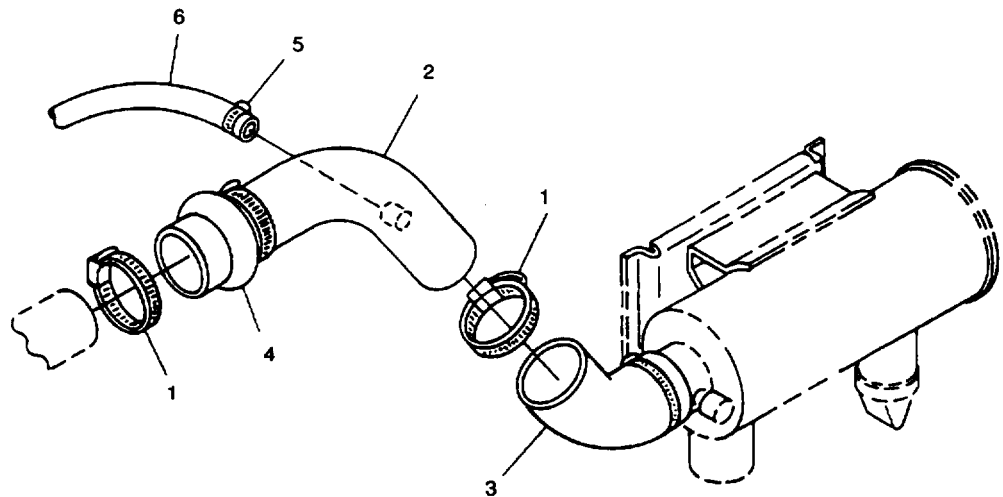

FIGURE 3-10. Air Cleaner Hose and Tube Assembly

- ah. Loosen damp (5) and connect hose (6) from tube (2). Remove tube (2) and hump hose (4) as an assembly.
- ai. Loosen damp (1, FIGURE 3-11) and disconnect oil drain hose (2) from adapter (3).
- aj. On left side of engine, tag and disconnect electrical leads from coolant high temperature switch (1, FIGURE 3-12), low oil pressure switch (2), oil pressure sender (3), coolant temperature sender (4), magnetic pickup (5), DEAD CRANK switch (6), and fuel injection pump (7).

- ak. Remove nut (8) from rod end (9). Loosen nuts (10) and remove governor actuator assembly (11) with wiring harness attached. Place out of the way.
- al. Loosen damp (12) and disconnect coolant drain hose (13) from engine block coolant drain valve (14).
- am. Remove bolt (15) and lockwasher (16) securing fuel return line (17) to engine block.
- an. Disconnect fuel line (17) at injectors excess fuel line, and fuel hose (18) at fuel tank. Remove line (17) and hose (18) as an assembly. Cap openings.

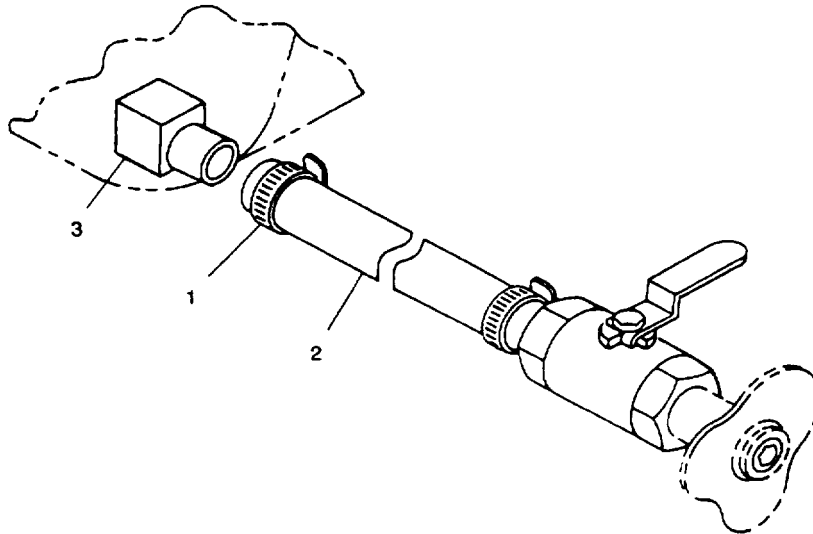

FIGURE 3-11. Oil Drain Hose

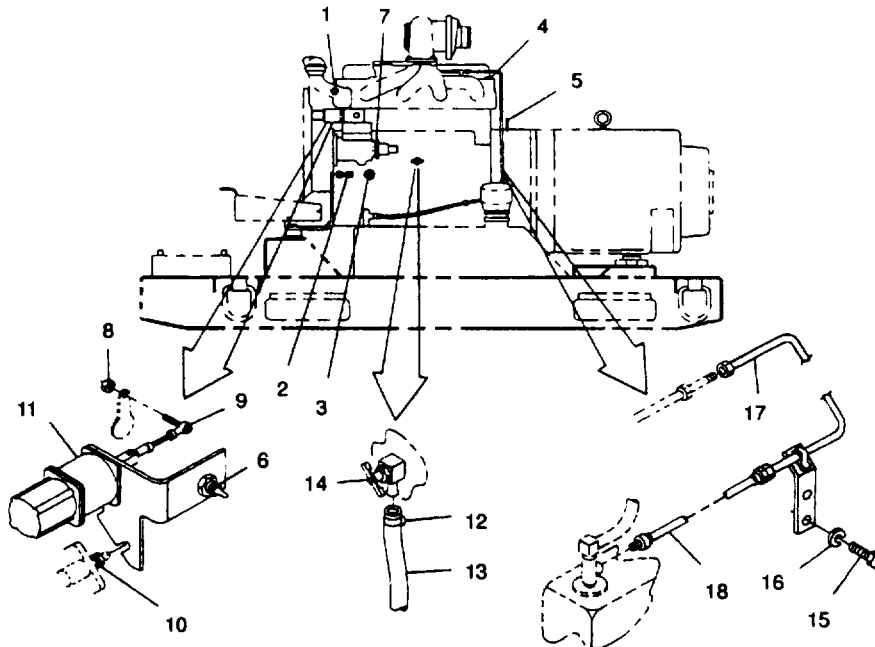

FIGURE 3-12. Left Side Engine

- ao. Open right side engine access doors, tag and dinned electrical leads from battery charging alternator (1, FIGURE 3-13). starter solenoid (2) and starter motor (3).
- ap. Disconnect fuel line (4) at fuel pump (5). Cap openings.
- aq. Disconnect tube (6) from ether start spray nozzle (7) at intake manifold.
- ar. Remove nut (1, FIGURE 3-14) lockwashers (2), and bolt (3) securing ground strap (4) to skid base.
- as. Remove bolts (5), washers (7), and lockwashers (6) securing load output terminal board assembly (8) to supports (9) and (10). Pull load output terminal board assembly out through access door.
- at. Remove assembled nuts (11), bolts (12), and support (10) from right side panel
- au. Loosen nuts (23 and 27, FIGURE 3-1), turn bolts (25) to contact skid base and tighten nuts (23) and (27).
- av. Remove nuts (30,) lockwashers (31), screws (32,) washers (33), and screen/cover (34) from generator case.

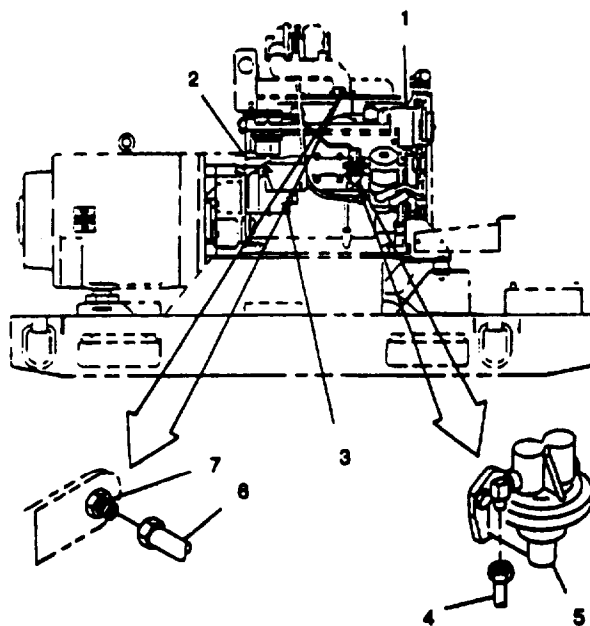

FIGURE 3-13. Right Side Engine

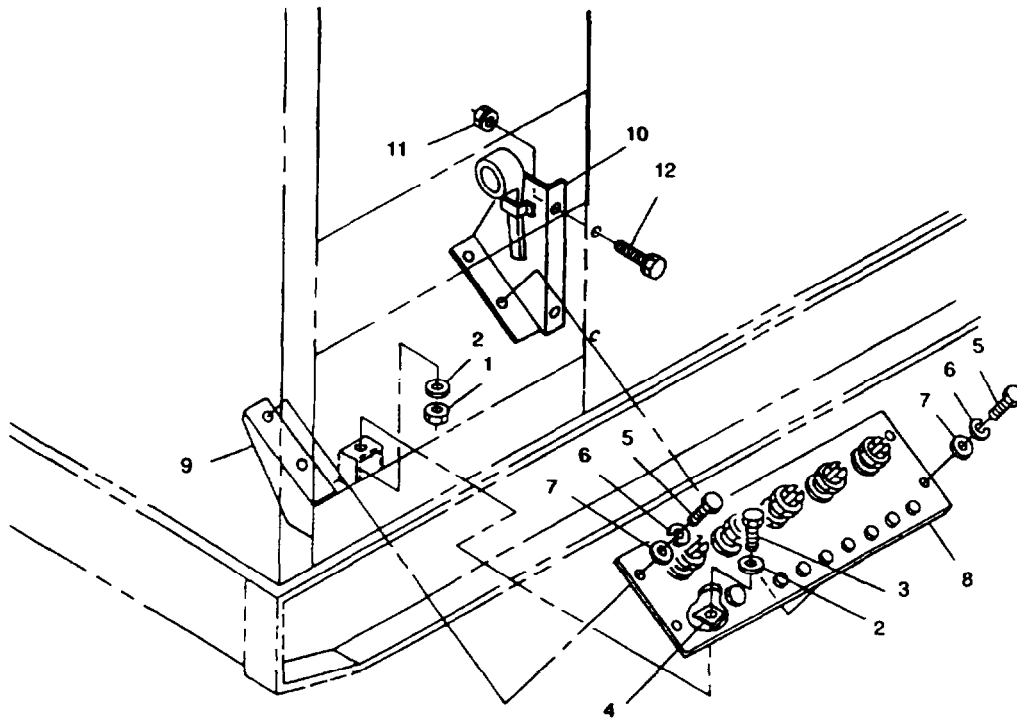

FIGURE 3-14. Load Output Terminal Board

- aw. Scribe mark on generator drive disc and engine flywheel for alignment of bolts during installation.
- ax. Remove bolts (35) and lockwashers (36) securing generator disc drive to engine flywheel.

WARNING

Rated capacity of overhead hoist should be at least 1,500 lbs (680 kg). Using a hoist with less capacity could result in equipment damage, personal injury, or death.

- ay. Attach lifting harness to engine and overhead hoist. Take up slack.
- az. Remove bolts (38) and lockwashers (39) securing generator to flywheel housing.
- ba. Remove nuts (1), washers (2), snubbing washers (3), and bolts (4) securing mount brackets (5) to skid base.
- bb. Remove nuts (1, FIGURE 3-15) lockwashers (2), bolts (3), and radiator mounting bracket (4) from engine mount brackets (5).

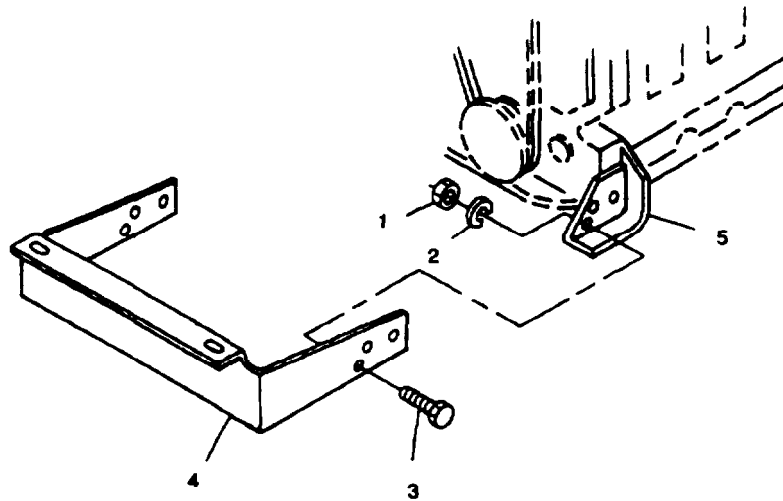

FIGURE 3-15. Radiator Mounting Bracket

WARNING

Keep hands and feet from under side of engine while using lifting device to remove the engine from the generator. Failure to observe this warning could result in serious personal injury and/or death.

- bc. With aid of an assistant, slowly lift engine assembly from skid base, ensuring that engine flywheel housing separates smoothly from generator without binding. Remove engine from generator set housing and place on engine stand.
- bd. Remove nuts (11, FIGURE 3-1) lockwashers (12) bolts (13) and shock mounts (14) from skid base.
- be. Remove bolts (16) lockwashers (17) washers (18) and mount brackets (5) from engine block.
- bf. Remove bolt (41) lockwashers (42) and front engine lifting bracket (43) from engine assembly.
- bg. Remove bolt (44), lockwasher (45), and rear engine lifting bracket (40) from engine assembly.
- bh. Remove bolts (19) lockwashers (20) washers (21) and rear engine support brackets (22) from engine assembly.

3-7-2 Installation.

- a. Install rear engine support brackets (22, FIGURE 3-1) on engine assembly with bolts (19), lockwashers (20) and washers (21).
- b. Install rear engine lifting bracket (40) on engine assembly with bolt (44), and lockwasher (45).
- c. Install front engine lifting bracket (43) on engine assembly with bolts (41) and lockwashers (42).
- d. Install mount brackets (5) on engine block with bolts (16), lockwashers (17), and washers (18).
- e. Install shock mounts (14) on skid base with bolts (13), lockwashers (12) and nuts (11).

WARNING

Rated capacity of overhead hoist should be at least 1,500 lbs (686 kg). Using a hoist with less capacity could result in equipment damage, personal injury, or death.

- f. Attach lifting harness to engine and overhead hoist. Take up slack.

NOTE

While lowering engine make sure oil drain line hose is fed through panel holes located in battery and engine compartment.

- g. With aid of an assistant, lift engine from engine stand and position engine on skid base, aligning mounting holes, brackets and generator to flywheel housing.
- h. Install bolts (38) and lockwashers (39), tightening bolts (38) slowly to ensure even and proper seating of generator housing lip to flywheel housing.
- i. Secure engine mount brackets (5) to skid base with bolts (4), snubbing washers (3), washers (2), and nuts (1). Torque bolts (4) to 75 ft-lbs (102 Nm).
- j. Align scribe mark on generator drive disc and engine flywheel, and install bolts (35) and lockwashers (36) securing generator drive disc to engine flywheel.
- k. Install screen/cover (34) on generator case with screws (32), washers (33), lock-washers (31), and nuts (30).
- l. Loosen nuts (23) and (27), adjust bolts (25) to obtain 0.5 inch (12.7 mm) minimum clearance with skid base. Torque nuts (23) to 150 ft-lbs (204 Nm).
- m. Install radiator mounting bracket (4, FIGURE 3-1 5) with bolts (3), lockwashers (2), and nuts (1) to engine mount brackets (5).
- n. Install support (10, FIGURE 3-14) on right side panel with bolts (12) and assembled nuts (11).
- o. Install load output terminal board assembly (8) on supports (9) and (10) with bolts (5), lockwashers (6), and washers (7).
- p. Secure ground strap (4) to skid base with bolt (3), lockwashers (2), and nut (1).
- q. Connect tube (6, FIGURE 3-13) to ether start spray nozzle (7) at intake manifold.
- r. Connect electrical leads to battery charging alternator (1), starter solenoid (2) and starter motor (3) on right side of engine, and remove tags.
- s. Remove caps and connect fuel line (4) to engine fuel pump (5).
- t. Remove caps and position fuel line (17, FIGURE 3-12) and hose (18) in generator set. Connect line (17) to injectors excess fuel line, and hose (18) to fuel tank.
- u. Secure fuel line (17) to engine block with bolt (15) and lockwasher (16).
- v. Connect coolant drain hose (13) to engine block coolant drain valve (14) and tighten damp (12).
- w. Install governor actuator assembly (11) to engine assembly with nuts (10). and connect rod end (9) with nut (8).

- x. On left side of engine, connect electrical leads to fuel injection pump (7), DEAD CRANK switch (6), magnetic pickup (5), coolant temperature sender (4), oil pressure sender (3), low oil pressure switch (2), and coolant high temperature switch (1). Remove tags.
- y. Connect oil drain hose (2, FIGURE 3-11) to adapter (3) and tighten damp (1).
- z. Connect tube (2, FIGURE 3-10) to hose (3), connect hump hose (4) to turbocharger, and tighten damp (1).
- aa. Connect hose (6) to tube (2) and tighten damp (5).
- ab. With aid of an assistant, position left rear side housing panel (4, FIGURE 3-9) and lower side panel (12) on generator set.
- ac. Secure left rear side panel (4) to skid base with bolts (1), lockwashers (2), and washers (3).
- ad. Secure lower left side panel (12) to front housing and skid base with bolts (5) and (10), washers (7) and (11), lockwashers (6) and (9), and nuts (8).
- ae. Connect auxiliary fuel pump (8, FIGURE 3-8) and fuel float switch module (9) electrical connectors and remove tags.
- af. Remove caps and connect fuel hose (7) to fuel line (6).
- ag. Remove caps and connect hose (4) to fuel filler panel assembly (5) and tighten damp (3).
- ah. Remove caps and connect hose (2) to fuel tank and tighten damp (1).
- ai. Install rear housing panel (8, FIGURE 3-7) on generator set with bolts (1) and (4), washers (3) and (5), lockwashers (2) and (6), and nuts (7).
- aj. With aid of an assistant, position radiator assembly (23, FIGURE 3-6) in generator set with nuts (21) and lockwashers (22).
- ak. Connect hose (17) to water pump and tighten clamp (16).
- al. Connect hose (15) at thermostat housing and tighten damp (14).
- am. Connect hose (19) at radiator drain valve (20) and tighten damp (18).
- an. Secure support rods (13) to front engine lifting bracket with bolts (11), washers (12), lockwashers (10), and nuts (9).
- ao. Position spacer (8), fan (7), and shroud (4) in generator set.
- ap. Secure spacer (8) and fan (7) on water pump with bolts (5) and lockwashers (6). Torque bolts (5) to 24 ft-lbs (33 Nm).
- aq. Install shroud (4) on radiator assembly (23) with bolts (1), washers (3), and lockwashers (2).
- ar. Install fan guards, paragraph 2-78-3.
- as. Using lifting device, position top housing section (10, FIGURE 3-5) on generator set.
- at. Secure top housing section (10) to output box angle with bolt (9) and assembled nut (8).
- au. Secure top housing section (10) to rear side panels with bolts (7) and assembled nuts (6).
- av. Secure top housing section (10) to front housing with bolts (4), flat washers (5), lockwashers (3), and nuts (2).

- aw. Connect exhaust pipe to turbocharger outlet and install damp(1).
- ax. Install overflow bottle assembly (5, FIGURE 3-4) on right side of engine with bolts (3) and lockwashers (4).
- ay. Connect hose (2) on overflow bottle assembly (5) with clamp (1).
- az. Position filler hose and panel assembly (5, FIGURE 3-2) in generator set. Connect filler hose and panel assembly (5) to radiator (2) and tighten damp (1).
- ba. Connect overflow hose (4) to filler hose and panel assembly (5) and tighten damp (3).
- bb. Install new ties (6) on radiator supports (7) to secure overflow hose (4).
- bc. Install top housing panel (7, FIGURE 3-2) with bolts (1) and (4), lockwashers (2) and (5), and washers (3) and (6).
- bd. Service coolant system, paragraph 2-1-2-2.
- be. Service lubrication system, paragraph 2-1-2-4.
- bf. Install control box assembly, paragraph 2-19-4.
- bg. Connect negative battery cable and close battery access door.
- bh. Close all access doors.
- bi. Start generator set, check for leaks and proper operation.
- bj. Shut down generator set and service fluid levels as necessary.

3-7-3 REPAACEMENT

- a. Remove of old engine assembly from generator set, paragraph 3-7-1.
- b. Remove the following from new engine and return with old engine:
 - (1) Cooling fan.
 - (2) Fan spacer.
 - (3) Fan belt.
- c. Disconnect throttle lever cable (1, FIGURE 3-1 6) from fuel injection pump of old engine.
- d. Remove throttle lever cable bracket (2), with cable (1) attached, from old engine and install on new engine.
- e. Connect throttle lever cable (1) to fuel injection pump lever of new engine.
- f. Remove the following from old engine and install on new engine:
 - (1) Oil sample valve and low oil pressure switch assembly (3, FIGURE 3-16).
 - (2) Alternator guard (1, FIGURE 3-17). Use hardware from old engine.
 - (3) Fuel filter drain valve assembly (2, FIGURE 3-17).
 - (4) Oil drain line elbow (7, FIGURE 2-31) with hose (4) attached.

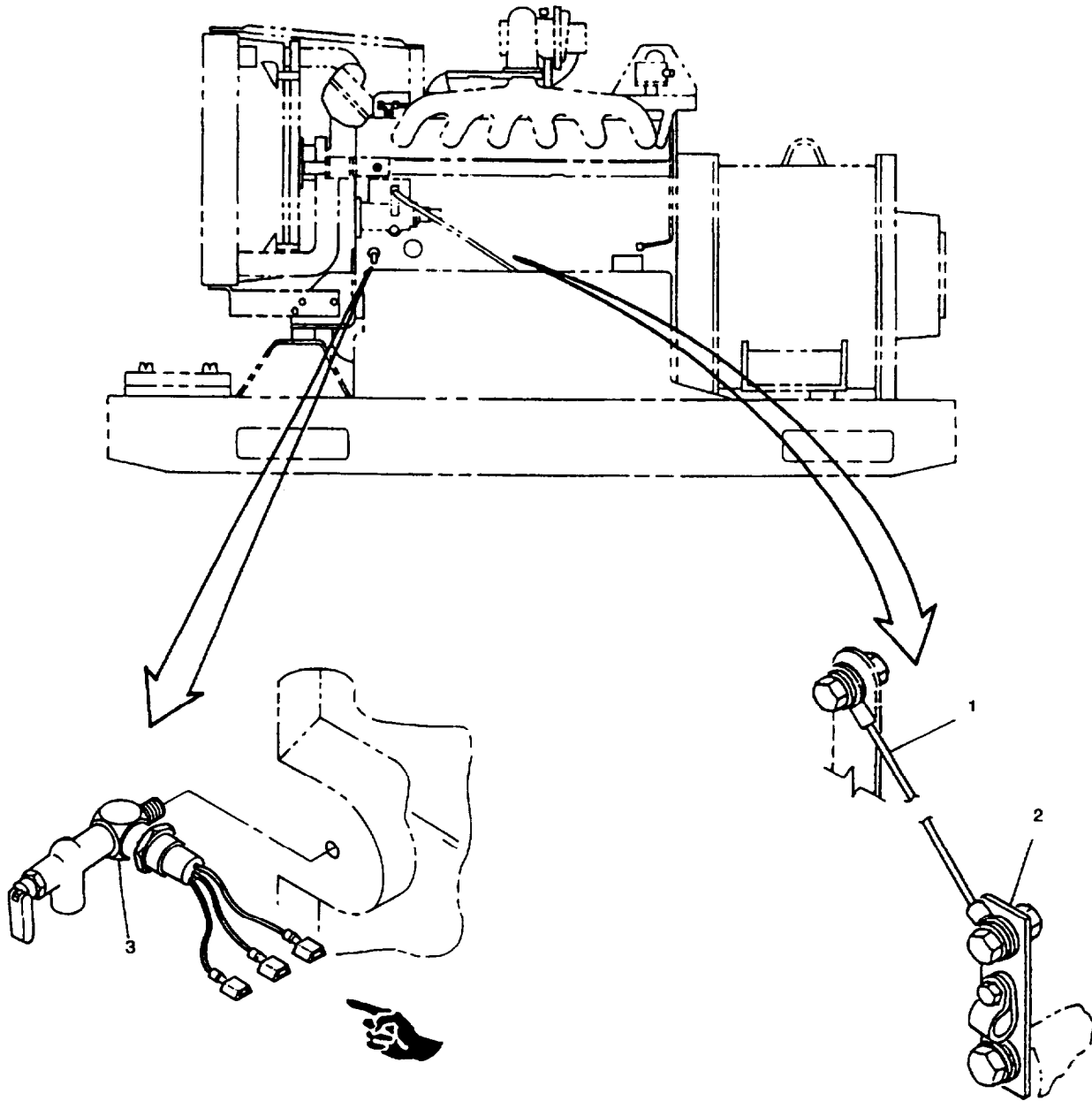

FIGURE 3-16. Engine Components (Left Side)

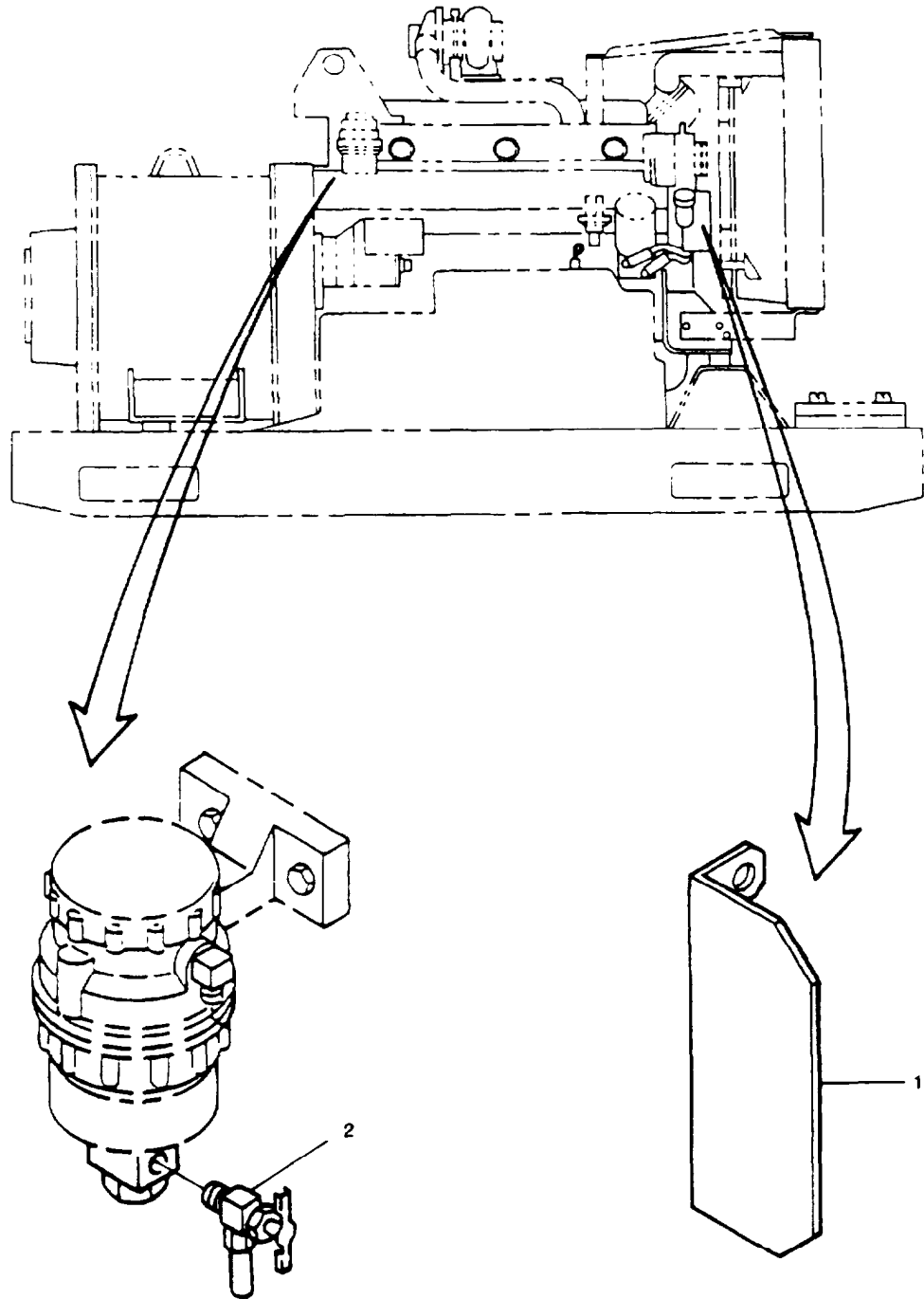

FIGURE 3-17. Engine Components (Right Side)

- (5) Governor actuator bracket (18, FIGURE 4-8) with governor actuator (11) and linkage, and DEAD CRANK switch (11, FIGURE 2-30) attached. Use hardware from old engine.
 - (6) Either start spray nozzle (9, FIGURE 2-27).
 - (7) Oil pressure sender (2, FIGURE 2-30).
 - (8) Coolant drain valve (3, FIGURE 2-30).
 - (9) Coolant temperature sender (4, FIGURE 2-30).
 - (10) Coolant high temperature switch (5, FIGURE 2-30).
 - (11) Magnetic pickup (6, FIGURE 2-30). Screw into flywheel housing until magnetic pickup bottoms out, back out 1-1/2 turns and tighten jam nut.
 - (12) Diode assembly (13, FIGURE 2-30). Install with band end toward engine.
 - (13) Fan belt (6, FIGURE 2-25).
- m. Install new engine in generator set, paragraph 3-7-2.
 - h. Check and adjust governor actuator as necessary, paragraph 4-15-4.
 - i. Check and adjust magnetic pickup as necessary, paragraph 2-110-4.
 - j. Check and adjust fan belt as necessary, paragraph 2-84-2.
 - k. Start generator set, check for leaks and proper operation.

CHAPTER 4

DIRECT SUPPORT MAINTENANCE INSTRUCTIONS

Section I. MAINTENANCE OF CONTROL BOX ASSEMBLY

4-1 AC VOLTAGE REGULATOR.

WARNING

High voltage is produced when this generator set is in operation. Improper operation could result in personal injury or death.

4-1-1 Testing (Regulator P/N: 112-3055 For MEP-805A Generator Set).

- a. Shut down generator set.
- b. Open output box access door.
- c. Note position of voltage reconnection terminal board and set FREQUENCY SELECT switch to 60 Hz position.
- d. Start generator set and turn VOLTAGE adjust potentiometer to ensure the adjustment ranges on TABLE 4-1 are met, depending on position of voltage reconnection terminal board.
- e. Shut down generator set.
- f. If no voltage or low voltage was indicated, or voltage adjustment range could not be achieved, perform the following steps. Otherwise, AC voltage regulator (2, FIGURE 4-3) is serviceable.
- g. Disconnect wire 141 A from terminal 1 of AC voltage regulator.
- h. Set multimeter for DC volts and connect positive lead to wire 141A. Connect negative lead of multimeter to terminal 3 of AC voltage regulator. Start generator set and operate at rated frequency. Move and hold MASTER SWITCH in START position. Multimeter should indicate between 4 and 12 VDC. If no voltage, proceed to troubleshooting, Governor Control Unit, paragraph 4-2.
- i. Shut down generator set. Isolate wire 141A.
- j. Set multimeter for AC volts and connect to terminals 10 and 11 of AC voltage regulator. Start generator set and operate at rated frequency. Move and hold MASTER SWITCH in START position. Multimeter should indicate 280 to 380 VAC. If no voltage or low voltage is indicated in step k above, proceed to troubleshooting the transformer, paragraph 4-12.
- k. Shut down generator set.
- l. Disconnect wire 137A from terminal 5 of AC voltage regulator. Set multimeter for ohms and connect positive lead to wire 137A and negative lead to terminal 4 of AC voltage regulator. Move VOLTAGE adjust potentiometer to full counterclockwise position. Multimeter should indicate approximately 3,000 ohms with FREQUENCY SELECT switch in 80 Hz position, and approximately 0 ohms with FREQUENCY SELECT switch in 50 Hz position. Move VOLTAGE adjust potentiometer clockwise slowly while observing multimeter. Multimeter should increase smoothly to approximately 10,000 ohms.
- m. Place FREQUENCY Select Switch in 60Hz position.

TABLE 4-1. Voltage Adjustment Range (MEP-805A)

Voltage Reconnection Terminal Board Position	Adjustment Range
120/208 240/416	197-240 volts 395-480 volts

- n. If steps h, j, and l are as indicated above, AC voltage regulator is defective and must be replaced.

NOTE

To replace Voltage Regulator, See paragraph 4-1-4 and 4-1-5.

- o. Connect all wires previously disconnected.
- p. Close output box access door.

4-1-2 Testing. (Regulator, R/N: 19880-001 For MEF-805A Generator Set.

- a. Shut down generator set.
- b. Open output box access door.
- c. Note position of voltage reconnection terminal board and set FREQUENCY SELECT switch to 60 Hz position.
- d. Start generator set and turn VOLTAGE adjust potentiometer to ensure the adjustment ranges on TABLE 4-1 are met, depending on position of voltage reconnection terminal board.
- e. Shut down generator set.
- f. If no voltage or low voltage was indicated, or voltage adjustment range could not be achieved, perform the following steps. Otherwise, AC voltage regulator (2, FIGURE 4-3) is serviceable.
- g. Disconnect wire 141A from terminal 1 of AC voltage regulator.
- h. Set multimeter for DC volts and connect positive lead to wire 141A. Connect negative lead of multimeter to terminal 3 of AC voltage regulator. Start generator set and operate at rated frequency. Move and hold MASTER SWITCH in START position. Multimeter should indicate between 4 and 12 VDC.
- i. Shut down generator set. Isolate wire 141A.
- j. Set multimeter for AC volts and connect to terminals 10 and 11 of AC voltage regulator. Start generator set and operate at rated frequency. Move and hold MASTER SWITCH in START position. Multimeter should indicate 110 to 160 VAC.
- k. Shut down generator set.
- l. Disconnect wire 137A from terminal 5 of AC voltage regulator. Set multimeter for ohms and connect positive lead to wire 137A and negative lead to terminal 4 of AC voltage regulator. Move VOLTAGE adjust potentiometer to full counterclockwise position. Multimeter should indicate no more than 2 ohms with FREQUENCY SELECT switch in 60 Hz position or 50 Hz position. Move VOLTAGE adjust potentiometer clockwise slowly while observing multimeter. Multimeter should increase smoothly to approximately 20,000 ohms.
- m. If steps h, j, and l are as indicated above, AC voltage regulator is defective and must be replaced.

- n. Connect all wires previously disconnected.
- o. Close output box access door.

4-1-3 Testing. (Regulator. P/N: 19890-002 For MEF-815A Generator Set).

- a. Shut down generator set.
- b. Open output box access door.
- c. Note position of voltage reconnection terminal board.
- d. Start generator set and turn VOLTAGE adjust potentiometer to ensure the adjustment ranges on TABLE 4-2 are met, depending on position of voltage reconnection terminal board.
- e. Shut down generator set.
- f. If no voltage or low voltage was indicated, or voltage adjustment range could not be achieved, perform the following steps. Otherwise, AC voltage regulator (2, FIGURE 4-3) is serviceable.
- g. Disconnect wire 141A from terminal 1 of AC voltage regulator.
- h. Set multimeter for DC volts and connect positive lead to wire 141A. Connect negative lead of multimeter to terminal 3 of AC voltage regulator. Start generator set and operate at rated frequency. Move and hold MASTER SWITCH in START position. Multimeter should indicate between 4 and 12 VDC.
- i. Shut down generator set. Isolate wire 141A.
- j. Set multimeter for AC volts and connect to terminals 10 and 11 of AC voltage regulator. Start generator set and operate at rated frequency. Move and hold MASTER SWITCH in START position. Multimeter should indicate 110 to 160 VAC.
- k. Shut down generator set.
- l. Disconnect wire 137A from terminal 5 of AC voltage regulator. Set multimeter for ohms and connect positive lead to wire 137A and negative lead to terminal 4 of AC voltage regulator. Move VOLTAGE adjust potentiometer to full counterclockwise position. Multimeter should indicate approximately 0 ohms. Move VOLTAGE adjust potentiometer clockwise slowly while observing multimeter. Multimeter should increase smoothly to approximately 20,000 ohms.

TABLE 4-2. Voltage Adjustment Range (MEP-815A)

Voltage Reconnection Terminal Board Position	Adjustment Range
1 20/208 240/41 6	197-229 volts 395-458 volts

- m. If steps h, j, and l are as indicated above, AC voltage regulator is defective and must be replaced.
- n. Connect aft wires previously disconnected.
- o. Close output box access door.

4-1-4 Removal.

- a. Shutdown generator set.
- b. Open battery access door and disconnect negative battery cable.
- c. Release control panel by turning two fasteners and lower control panel slowly.
- d. Tag and disconnect AC voltage regulator (2, FIGURE 4-3) electrical leads.
- e. Remove screws (1) and AC voltage regulator (2).

4-1-5 Installation.

CAUTION

The components of the AC voltage regulator kit are not interchangeable. Ensure the part number of the component to be installed is the same as the removed component. Failure to observe this caution will result in equipment damage.

- a. Install AC voltage regulator (2, FIGURE 4-3) with screws (1).
- b. Connect electrical leads and remove tags.
- c. Raise and secure control panel.
- d. Connect negative battery cable. Close battery access door.

4-2 SHORT CIRCUIT/OVERLOAD RELAY

4-2-1 Testing

CAUTION

Make sure negative battery cable is disconnected prior to removing wires. Failure to observe this caution could result in equipment damage.

- a. Remove short circuit/overload relay, paragraph 2-56-3.
- b. Install relay in test circuit (FIGURE 4-?)
- c. Set multimeter for OHMS and check for open circuits between terminals 5 and 6, 9 and 10,. Check for closed circuits between terminals 7 and 8, 11 and 12. If relay fails the above test, replace relay. If relay tests good, continue with remainder of test.
- d. Activate power source G1. Adjust voltage to 0 volts.
- e. Place switch S2 in the "A" position and close S1.
- f. Slowly increase output voltage of G1 to 6.18 VAC (110% rated load). Leave G1 at this setting for 10 minutes. Relay should not trip, circuits should remain as indicated in step c above.
- g. Set multimeter for OHMS and check across terminals 5 and 6 while slowly increasing output voltage of G1 to 7.30 VAC (130% rated load). The relay should trip within 8+/- 2 minutes. When relay trips circuit 5 and 6 should close, circuit 7 and 8 should open.

- h. With multimeter set on OHMS, check across terminals 9 and 10. Slowly increase output voltage of G1. When voltage reaches 23.9 +/-1.4 VAC the relay should trip. When relay trips, circuit 9 and 10 should close and circuit 11 and 12 should open.
- i. Return output voltage of G1 to 0 and open S1 allowing relay to reset.
- j. Place switch S2 in "B" position and close switch S1.
- k. Repeat steps f. through i.
- l. Place switch S2 in "C" position and close switch S1.
- m. Repeat steps f. through i.
- n. The voltages at which relay trips in positions A, B, and C should be within 1 volt.
- o. Replace any relay found to be defective.
- p. Install relay, paragraph 2-56-4.

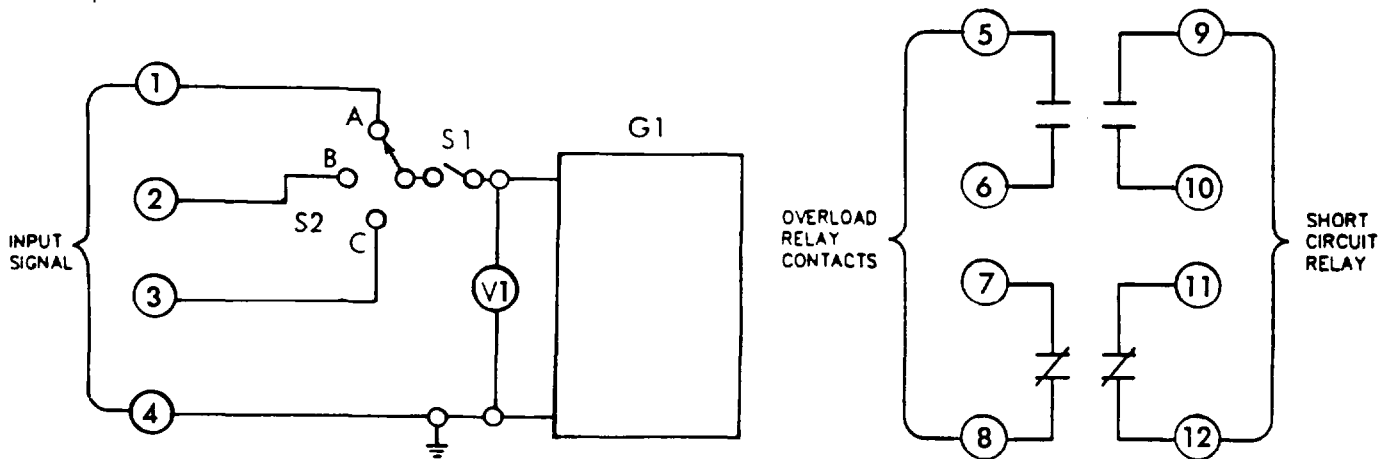

FIGURE 4-1. Test Circuit

4-3 GOVERNOR CONTROL UNIT.

WARNING

High voltage is produced when this generator set is in operation. Improper operation could result in personal injury or death.

4-3-1 Troubleshooting Procedures

- a. While holding the Master Switch (S-1) in the "START" position, check for the voltage from pin positions 1,3,5 on the GCU (A-5) to Ground. The readings should be battery voltage. If there is no voltage between any of the connections, the GCU (A-5) is not receiving the proper voltage and the wiring harness should be checked. Refer to FO-1.

NOTE

With the generator running the voltage will read zero.

- b. Place Master Switch in OFF position. Connect multimeter leads to terminals 19 & 20 on the governor control unit (A-5), then move master switch to START position. Reading should be battery voltage when generator does not crank. If there is no voltage between terminal positions, the GCU (A-5) is not functioning properly and should be replaced.

NOTE

With the generator running there will be battery voltage.

- c. Place Master Switch in OFF position. Connect multimeter leads to terminals 19 & 18 on the governor control unit (A-5), then move master switch to START position, reading should be zero voltage when generator does not crank. If there is voltage between the terminal positions, the GCU (A-5) is not functioning properly and should be replaced.

4-3-2 Testing.

- a. Shut down generator set.
- b. Open output box access door. Remove protective cover and attach voltage and frequency recorder to terminals 9 and 12 of voltage reconnection terminal board.
- c. Open load terminal board access door and attach load bank to generator set (4 wire connection).

NOTE

Ensure load bank and generator set voltage reconnection are set for same configuration (i.e., 120/208 or 240/416 VAC).

- d. Start and operate generator set at rated voltage and frequency.
- e. Turn on voltage and frequency recorder and operate at minimum chart speed of 5 mm/sec (chart resolution of 0.2 sec/mm). Adjust recorder voltage amplifier for a minimum chart resolution of 1.0 volt/mm, and frequency deviation amplifier for a minimum resolution of 0.2 Hz/mm.
- f. Set load bank for a load equal to 75% of generator set rated load.
- g. Apply and remove the 75% load to the generator set at 40 second intervals three times.
- h. Repeat steps f and g at 50% rated load.
- i. Repeat steps f and g at 25% rated load.
- j. Repeat steps f and g at 100% rated load.
- k. Shut down generator set.
- l. Turn off voltage and frequency recorder.
- m. Examine voltage and frequency recorder chart. Generator set should meet the following performance criteria:
 - (1) Frequency regulation shall not exceed 1/4 of 1 percent of rated frequency.
 - (2) Frequency short-term stability (30 seconds), frequency will remain constant within a band width equal to 1/2 of 1 percent rated frequency, without repetitive frequency variations, commonly called "hunting".

- (3) The generator set will reestablish stable engine operating conditions within 2 seconds of a sudden load change (within 1 second for 400 Hz unit). The maximum transient frequency change above or below (overshoot or undershoot) the new steady state frequency shall not be more than 4 percent of rated frequency (not more than 1-1/2 percent for 400 Hz unit).
- n. If the above criteria is not met, adjust the governor control unit (3, FIGURE 4-3) in accordance with paragraph 4-2-3.
- o. If the above criteria cannot be met by adjustment, the governor control unit must be replaced.
- p. Disconnect load bank and disconnect load terminal board access door.
- q. Disconnect voltage and frequency recorder, install voltage reconnection terminal board protective cover and disconnect output box access door.

4-3-3 Adjustment.

- a. Shutdown generator set.
- b. Open output box access door, remove cover from voltage reconnection terminal board and attach voltage and frequency recorder to terminals 9 and 12 of voltage reconnection terminal board.

NOTE

The following procedures require monitoring frequency, voltage, current, and power. All readings except for frequencies will utilize the generator set control panel gages. However, since the designed overspeed trip frequency is greater than the range of the control panel FREQUENCY meter (HERTZ), a frequency counter will be required.

- c. Attach frequency counter to voltage reconnection terminal board terminals 9 and 12.
- d. Open load terminal board access door and attach load bank to generator set (four wire connection).

NOTE

Ensure load bank and generator set voltage reconnection are set for same configuration (i.e., 120/206 or 240/416 VAC).

- e. Check for proper adjustment of governor actuator, paragraph 4-15-4. Adjust as necessary.
- f. Check for proper adjustment of magnetic pickup, paragraph 2-110-4. Adjust as necessary.
- g. Lower generator set control panel and turn INTEG, WV GAIN, and LOAD PULSE potentiometer on governor control unit to their full counterclockwise positions.

NOTE

It is necessary to adjust fuel injection pump high idle stop screw to allow increased engine idle speed for overspeed test. Record number of turns so screw can be reset after test.

- h. Loosen jam nut (1, FIGURE 4-2) and back out high idle stop screw (2) on fuel injection pump.

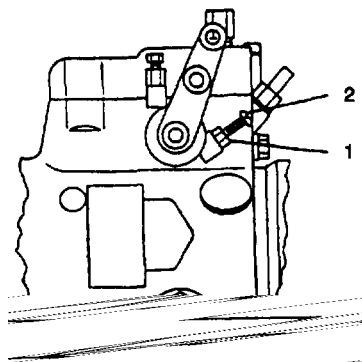

FIGURE 4-2. Fuel Injection Pump High Idle Speed Adjustment

- i. Start generator set and operate at rated voltage and frequency.
- j. Observing frequency counter, slowly increase operating frequency of generator set by turning governor control unit FREQ range potentiometer clockwise until frequency counter indicates between 65.94 and 66.06 Hz (MEP-805A) or between 436 and 444 Hz (MEP-815A). At this point generator set has reached overspeed trip frequency and generator set should shut down.

NOTE

Perform steps k and 1 if generator set does not shut down within limits noted in step j. Otherwise, proceed to step m.

- k. If generator set has not shutdown at upper limit of frequency noted in step j, proceed as follows:
 - (1) Turn FREQ range potentiometer counterclockwise until frequency counter indicates midrange of overspeed trip frequency [Example: 66 Hz (MEP-805A)].
 - (2) Turn OVERSPD control potentiometer on governor control unit counterclockwise until generator set shuts down.
 - (3) Activate OVERSPD RESET switch.
 - (4) Repeat steps i and j.
- l. If generator set shuts down prior to reaching lower limit of frequency noted in step j, proceed as follows
 - (1) Turn OVERSPD control potentiometer clockwise one turn for each hertz generator set shutdown prior to lower frequency limit.
 - (2) Activate OVERSPD RESET switch.
 - (3) Repeat steps i and j.
- m. Actuate OVERSPD RESET switch.
- n. Loosen jam nut (1, FIGURE 4-1), set high idle stop screw (2) to position recorded for step h, and tighten jam nut (1).

- o. Turn FREQ range potentiometer on governor control unit two turns, counterclockwise.
- p. Start and operate generator set at rated voltage and turn FREQUENCY adjust potentiometer on control panel to midrange.
- q. Turn FREQ range potentiometer until rated frequency (50, 60 or 400 Hz) is indicated on control panel FREQUENCY meter (HERTZ).
- r. Set load bank for generator set rated load and apply bat. Observe generator set instruments and adjust load as needed to ensure rated load is applied.
- s. Set multimeter for DC volts and connect to terminals 11 and 12 of governor control unit (3, FIGURE 4-3).
- t. Adjust LOAD SHARING ADJUST rheostat until multimeter indicates 6 VDC. Disconnect multimeter.
- u. Remove load.
- v. Turn on voltage and frequency recorder and operate at minimum chart speed of 5 mm/see (chart resolution of 0.2 mm/sec). Adjust recorder voltage amplifier for minimum chart resolution of 1.0 volt/mm and frequency deviation of 0.2 Hz/mm.
- w. Adjust GOV GAIN potentiometer on governor control unit as follows:
 - (1) Turn GOV GAIN potentiometer to its full clockwise position.
 - (2) Momentarily actuate and turn off LOAD switch on control panel.
 - (3) Observe strip chart on recorder for frequency oscillation (hunting). If required, slowly turn GOV GAIN counterclockwise until frequency oscillation disappears.
- x. Apply and remove rated load to generator set at 40-second intervals. Repeat this step two more times.
- y. Shut down generator set and turn off recorder.
- z. Examine voltage and frequency strip chart for the following performance criteria:
 - (1) Frequency regulation shall not exceed 1/4 of one percent of rated frequency.
 - (2) Frequency short-term stability (30 seconds), frequency will remain constant within a band width equal to 1/2 of 1 percent rated frequency, without repetitive frequency variations (hunting).
 - (3) The generator set will reestablish stable ermine operation within two seconds of a sudden load charge (i.e., from a load to no-load condition) (within one second for 400 Hz units). The maximum transient frequency change above (overshoot) and below (undershoot) the new steady state frequency shall not be more than 4 percent of rated frequency (not more than 1-1/2 percent for 400 Hz units).

NOTE

All required INTEG and LOAD PULSE potentiometer adjustments will be in 10 percent increments.

- aa. Adjust INTEG potentiometer on governor control unit clockwise to decrease recovery time of load transients.
- ab. Adjust LOAD PULSE potentiometer on governor control unit clockwise to decrease frequency overshoot and undershoot and to decrease recovery time of overshoot/undershoot transients.
- ac. Start generator set.

NOTE

Steps w(1) and w(2) are not required when doing step ad.

- ad. Repeat steps v through x until generator set meets performance requirements stated in step z.
- ae. Apply and remove 75 percent rated load to generator set at 40-second intervals. Repeat this step two more times.
- af. Apply and remove 50 percent rated load to generator set at 40-second intervals. Repeat this step two more times.
- ag. Apply and remove 25 percent rated load to generator set at 40-second intervals. Repeat this step two more times.
- ah. Shut down generator set and turn off strip chart recorder.
- ai. Examine voltage and frequency strip chart for the following performance criteria:
 - (1) Frequency regulation shall not exceed 1/4 of one percent of rated frequency
 - (2) Frequency short-term stability (30 seconds), frequency will remain constant within a band width equal to 1/2 of 1 percent rated frequency, without repetitive frequency variations (hunting),
 - (3) The generator set will reestablish stable engine operation within two seconds of a sudden load change (i.e., from a load to no-load condition) (within one second for 400 Hz units). The maximum transient frequency change above (overshoot) and below (undershoot) the new steady state frequency shall not be more than four percent of rated frequency (not more than 1-1/2 percent for 400 Hz units).
- aj. Disconnect load bank and close load terminal board access door.
- ak. Disconnect frequency counter, and voltage and frequency recorder from voltage reconnection terminal board.
- al. Install voltage reconnection terminal board cover and close output box access door.

4-3-4 Replacement.

- a. Remove governor control unit, paragraph 2-61-2.
- b. Install new governor control unit, paragraph 2-61-3.
- c. Perform adjustment of governor control unit, paragraph 4-3-3.

4-4 CONTROL BOX HARNESS.

4-4-1 Removal.

- a. Shutdown generator set.
- b. Open battery access door and disconnect negative battery cable.
- c. Remove control box assembly, paragraph 2-19-2.
- d. Remove voltage sensing relay, paragraph 2-59-3.
- e. Remove relays, paragraph 2-60-3.

- f. Remove screws (4, FIGURE 4-3), washers (5), insulators (6), and dips (7).
- g. Tag and remove sockets (8) from tracks (9).
- h. Remove screws (10) and nuts (11) to free terminal boards (12).
- i. Tag and disconnect electrical leads from AC voltage regulator (2) and governor control unit (3).
- j. Tag and disconnect electrical leads from shunt (43, FIGURE 2-14), BATTERY CHARGER FUSE assembly (32), DC CONTROL POWER circuit breaker (35), REACTIVE CURRENT ADJUST rheostat (3), LOAD SHARING ADJUST rheostat (7), FREQUENCY SELECT switch (14), OVERSPEED RESET switch (10), over/under voltage relay (45), frequency transducer (38), short circuit/overload relay (47), permissive paralleling relay (51), reverse power relay (49), load measuring unit (69), watt transducer (40), and resistor-diode assembly (71).
- k. Tag and disconnect electrical leads to CONVENIENCE RECEPTACLE (20), GROUND FAULT CIRCUIT INTERRUPTER (23), and connector to malfunction indicator panel (27).
- l. Tag and disconnect electrical leads to all indicators, switches, and lights on control panel.
- m. Remove screws (13 and 17, FIGURE 4-2), nuts (14) and (18), caps (16) and (20), diagnostic connector (15), parallel connector (19), and gaskets (21) and (22) from control box panel.
- n. Remove screws (23) and nuts (24) from harness connectors and remove harness assembly (25) from control box.

4-4-2 Inspection.

- a. Inspect control box harness wiring for breaks, damaged insulation, and loose or damaged terminals.
- b. Inspect harness connectors, sockets and terminal boards for cracks, corrosion, stripped threads, broken pins, and other visible damage.

4-4-3 Testing.

- a. Set multimeter for ohms.
- b. Check individual wires, connectors, and terminal boards for continuity. Refer to Wiring Diagram FO-2 for wire identification.

4-4-4 Repair.

- a. Replace damaged cable assemblies, terminals, connectors, sockets, and terminal boards.
- b. Replace or ensure proper connection of all wires not indicating continuity.

4-4-5 Installation.

- a. Position control box wiring harness assembly (25, FIGURE 4-3) in control box.
- b. Secure harness connectors to control box with screws (23) and nuts (24).
- c. Install gaskets (21) and (22), diagnostic connector (15), parallel connector (19), and caps (16) and (20) in control box panel with screws (13) and (17) and nuts (14) and (18).
- d. Connect all electrical electrical leads to control panel indicators, switches, and lights as tagged on removal. Remove tags.
- e. Connect electrical connector to malfunction indicator panel (27, FIGURE 2-1 4) and electrical leads to CONVENIENCE RECEPTACLE (20) and GROUND FAULT CIRCUIT INTERRUPTER (23).

- f. Connect electrical leads, as tagged during removal, to watt transducer (40), load measuring unit (69), reverse power relay (49), permissive paralleling relay (51), resistor-diode assembly (71), short circuit/overload relay (47), frequency transducer (38), over/under voltage relay (45), DC CONTROL POWER circuit breaker (35), BATTERY CHARGER FUSE assembly (32), OVERSPEED RESET switch (10), FREQUENCY SELECT select switch (14), REACTIVE CURRENT ADJUST rheostat (3), LOAD SHARING ADJUST rheostat (7), and shunt (43). Remove tags.
- g. Connect electrical leads to AC voltage regulator (2, FIGURE 4-3) and governor control unit (3). Remove tags.
- h. Secure terminal boards (12) to control box with screws (10) and nuts (11).
- i. Position sockets (8) on tracks (9) as tagged on removal.
- j. Secure sockets (8) to tracks (9) with dips (7), insulators (6), washers (5), and screws (4). Remove tags.
- k. Install relays, paragraph 2-60-4.
- l. Install voltage sensing relay, paragraph 2-59-4.
- m. Install control box assembly, paragraph 2-19-4.
- n. Connect negative battery cable and close battery access door.

4-5 LOAD MEASURING UNIT

WARNING

High voltage is produced when this generator set is in operation. Improper operation could result in personal injury or death.

4-5-1 Testing.

- a. Start and operate generator set at rated frequency and voltage.
- b. Apply a resistive load to generator set.
- c. Note reading on kilowattmeter (PERCENT POWER).
- d. Determine DC voltage (calculated value) from the kilowattmeter reading using the following formula:

$$\frac{10.8 \times (\text{kilowattmeter reading})}{100}$$

- e. Release control panel by turning two fasteners and lower control panel slowly.
- f. Set multimeter for DC volts and connect positive lead to terminal 11 of load measuring unit (26, FIGURE 4-3) and negative lead to terminal 12.
- g. Compare DC voltage (calculated value) to multimeter reading.
- h. Load measuring unit must be replaced if difference is more than ± 1.2 VDC.
- i. Shut down generator set.
- j. Remove multimeter from load measuring unit terminals.
- k. Raise and secure control panel.

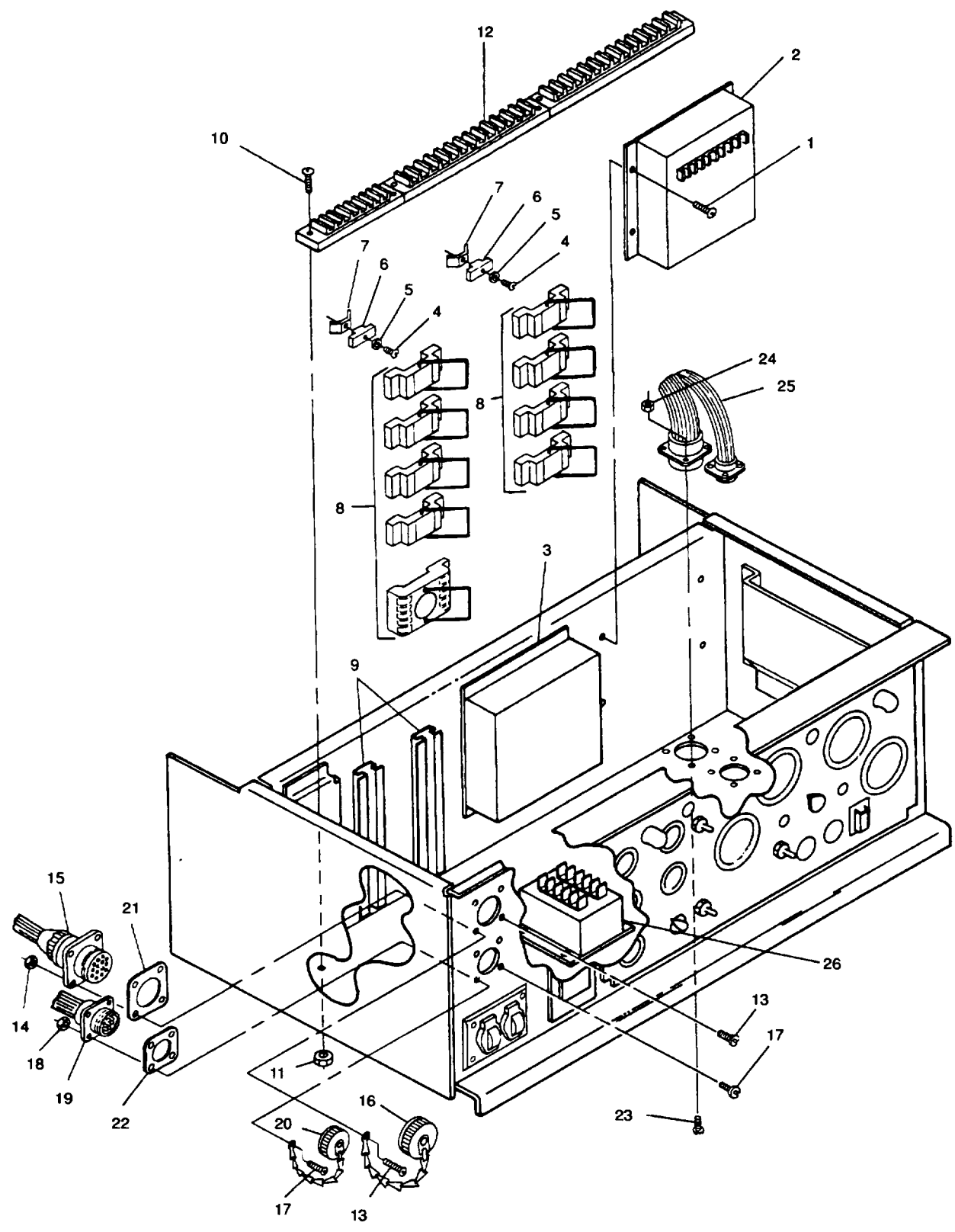

FIGURE 4-3. Control Box Components

4-5-2 Replacement

- a. Remove load measuring unit, paragraph 2-65-2.
- b. Install new load measuring unit, paragraph 2-65-3.

Section II. MAINTENANCE OF COOLANT SYSTEM

4-6 RADIATOR.

Repair radiator in accordance with TM 750-254.

Section III. MAINTENANCE OF FUEL SYSTEM

4-7 FUEL TANK.

4-7-1 Inspection

- a. Shut down generator set.
- b. Remove fuel tank, paragraph 4-7-2.
- c. Inspect fuel tank (6, FIGURE 4-4) for leaks, cracks, missing hardware, and other damage.
- d. If no damage is found, install fuel tank, paragraph 4-7-3.

4-7-2 Removal.

- a. Shutdown generator set.
- b. Open battery access door and disconnect negative battery cable.

WARNING

Diesel fuel inflammable and toxic to eyes, skin, and respiratory tract. Skin/eye protection required. Avoid repeated/prolonged contact. Good general ventilation is normally adequate.

- c. Drain fuel tank
- d. Remove engine and generator assembly, paragraph 3-6-1.
- e. Remove fuel tank drain valve, paragraph 2-69-1.
- f. Remove nuts (1, FIGURE 4-4), lockwashers (2), washers (3), bolts (4) and plates (5) securing fuel tank to skid base.
- g. Remove fuel tank (6) from skid base.
- h. Remove low fuel level/ auxiliary fuel pump float switch, paragraph 2-91-2.
- i. Remove fuel level sender, paragraph 2-90-2.

- j. Remove fuel pickup, paragraph 2-92-1.
- k. Remove fittings (7) and (8) from excess fuel studs (10) on right side of tank
- l. Remove fitting (9) from excess fuel stud (10) on left side of tank.
- m. Remove studs (10), washers (11), and bushings (12) from fuel tank.
- n. Cover all openings.

4-7-3 Installation.

- a. Remove covers placed over openings.
- b. Install bushings (12, FIGURE 4-4), washers (11), and studs (10) in fuel tank (6).
- c. Install fitting (9) in excess fuel stud (10) on left side of fuel tank.
- d. Install fittings (7), and (8), in excess fuel studs (10) on right side of fuel tank.
- e. Install low fuel level/ auxiliary fuel pump float switch, paragraph 2-91-4.
- f. Install fuel level sender, paragraph 2-90-4.
- g. Install fuel pickup, paragraph 2-92-3.
- h. Install fuel tank (6) in skid and secure with plates (5), bolts (4), washers (3), lockwashers (2), and nuts (1).
- i. Install engine and generator assembly, paragraph 3-6-2.
- j. Install fuel tank drain valve, paragraph 2-89-2.
- k. Service fuel tank. Refer to TABLE 2-2 for proper fuel.
- l. Connect negative battery cable. Close battery access door.

Section IV. MAINTENANCE OF OUTPUT BOX ASSEMBLY

4-8 OUTPUT BOX ASSEMBLY

4-8-1 Removal.

- a. Shut down generator set.
- b. Open battery access door and disconnect negative battery cable.
- c. Remove control box assembly, paragraph 2-19-2.
- d. Remove top housing section, paragraph 2-16-1.
- e. Remove air cleaner assembly, paragraph 2-73-3.
- f. Remove output box access door, paragraph 2-14-1
- g. Remove rear housing panel, paragraph 2-18-1.

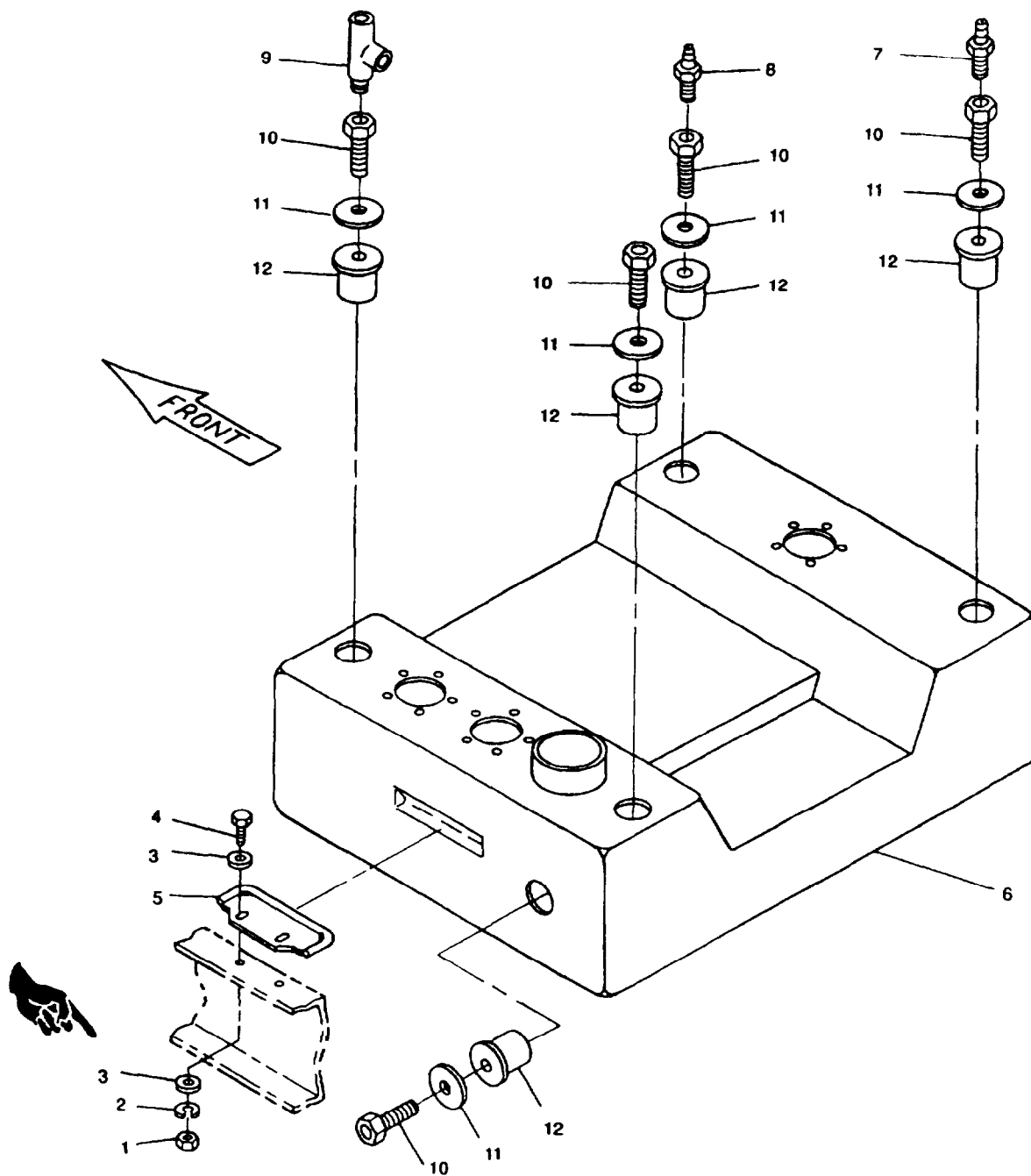

FIGURE 4-4. Fuel Tank

- h. Open left side engine access door, tag and disconnect electrical leads from fuel injection pump, governor actuator, coolant high temperature switch, DEAD CRANK switch, oil pressure sender, low oil pressure switch, coolant temperature sender, auxiliary fuel pump, fuel float module, fuel level sender, and magnetic pickup.
- i. Open right side engine access door, tag and disconnect electrical leads from battery charging alternator, starter, and ether solenoid valve.
- j. Note locations and remove loop dampers securing output box harness to engine.
- k. Remove voltage reconnection terminal board, paragraph 4-9-1.
- l. Remove nuts (1, FIGURE 4-5), bolts (2), and output box top panel (3) from output box assembly.

NOTE

Record number and direction of wraps when removing main generator cables from transformers to aid installation.

- m. Unwrap main generator cables from droop current transformer (34) and current transformer (31).
- n. Remove screws (4) and cover (5) from AC circuit interrupter relay (40).
- o. Tag and disconnect output cables from terminals A2, B2, and C2 of AC circuit interrupter relay (40).
- p. Tag and disconnect exciter leads F1 and F2 from terminals 1 and 2 of terminal board (26).
- q. Remove nuts (6), bolts (7), and output box assembly from generator set.

4-8-2 Installation.

- a. Install output box assembly in generator set with bolts (7, FIGURE 4-5) and nuts (6).
- b. Connect exciter leads F1 and F2 to terminals 1 and 2 of terminal board (26), and remove tags.
- c. Connect output cables to terminals A2, B2, and C2 of AC circuit interrupter relay (40), and remove tags.
- d. Install cover (5) on AC circuit interrupter (40) with screws (4).
- e. Install main generator cables onto current transformer (31) and droop current transformer (34) the same number of wraps recorded during removal.
- f. Install voltage reconnection terminal board, paragraph 4-9-2.
- g. Connect output box harness electrical leads to battery charging alternator, starter, and ether solenoid valve through right engine access doors and remove tags.
- h. Connect output box harness electrical leads to magnetic pickup, coolant temperature sender, auxiliary fuel pump, fuel float module, fuel level sender, low oil pressure switch, oil pressure sender, governor actuator, fuel injection pump, DEAD CRANK switch, and coolant high temperature switch through left engine access doors and remove tags.
- i. Install loop dampers securing output box harness to engine as noted during removal. Close engine access doors.
- j. Install output box top panel (3) with bolts (2) and nuts (1).
- k. Install top housing section, paragraph 2-16-4.
- l. Install air cleaner assembly, paragraph 2-73-4.

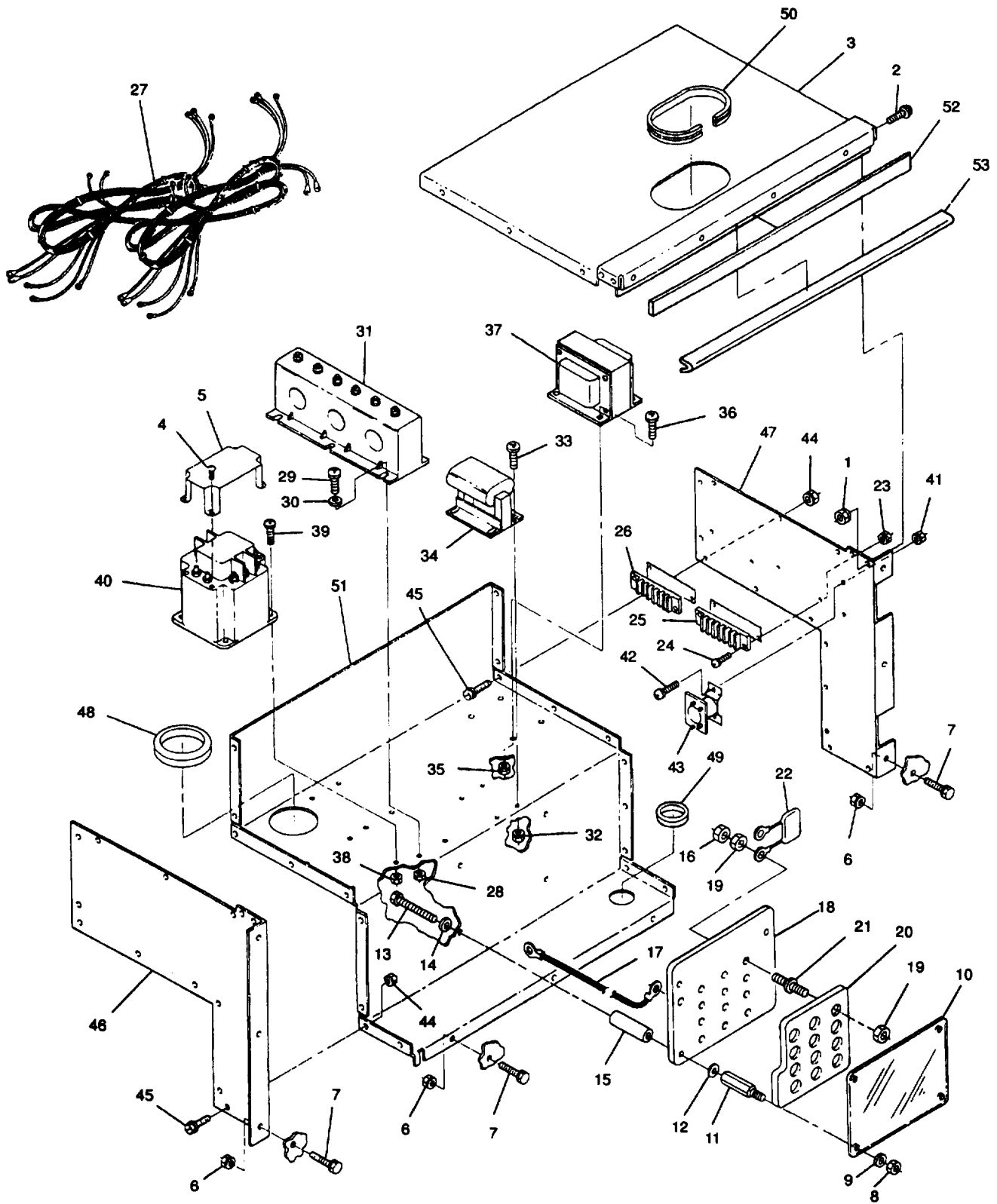

FIGURE 4-5. Output Box Assembly

- m. Install rear housing panel, paragraph 2-18-4.
- n. Install control box assembly, paragraph 2-19-4.
- o. Install output box access door, paragraph 2-14-4.
- p. Connect negative battery cable and dose battery access door.

4-9 VOLTAGE RECONNECTION TERMINAL BOARD.

4-9-1 Removal

- a. Shut down generator set.
- b. Open battery access door and disconnect negative battery cable.
- c. Open output box access door and load terminal board access door.
- d. Remove nuts (8, FIGURE 4-5), washers (9), and cover (10) from voltage reconnection board (18).
- e. Unscrew standoffs (11) and remove washers (12), bolts (13), washers (14), and mounts (15).
- f. Remove nuts (16), tag and disconnect electrical cables (17) and main generator cables from voltage reconnection board (18).
- g. Remove voltage reconnection board (18) and moveable terminal board (20) from generator set as assembly.
- h. Tag position of capacitors (22) on voltage reconnection board (18).
- i. Remove nuts (19), moveable terminal board (20), studs (21), and capacitors (22) from voltage reconnection board (18).

4-9-2 Installation.

- a. Insert studs (21, FIGURE 4-5) in voltage reconnection board (18). Position capacitors (22) as tagged, align moveable terminal board (20) with voltage reconnection board (18) and install nuts (19). Remove tags.
- b. Position voltage reconnection board (18) and moveable terminal board (20) in generator set.
- c. Connect electrical cables (17) and main generator cables to voltage reconnection board (18) with nuts (16) and remove tags.
- d. Secure voltage reconnection board (18) to generator set with bolts (13), washers (14), mounts (15), washers (12), and standoffs (11).
- e. Install cover (10) with washers (9) and nuts (8).
- f. Close output box and load terminal board access doors.
- g. Connect negative battery cable and dose battery access door.

4-10 OUTPUT BOX HARNESS.

4-10-1 Inspection.

- a. Remove output box harness, paragraph 4-10-2.
- b. Inspect wiring harness for burned, bent, corroded, and broken terminals.

- c. Inspect connectors for cracks, corrosion, stripped threads, bent or broken pins, and obvious damage.
- d. Inspect wire insulation for bumps, deterioration, and chafing.
- e. Install output box harness, paragraph 4-10-5.

4-10-2 Removal.

- a. Shut down generator set.
- b. Open battery access door and disconnect negative battery cable.
- c. Remove control box assembly, paragraph 2-19-2.
- d. Remove output box top panel, paragraph 4-8-1, step I.
- e. Open right side engine access doors, tag and disconnect electrical leads from battery charging alternator, starter solenoid, starter motor, and ether solenoid valve.
- f. Open left side engine access door, tag and disconnect electrical leads from coolant high temperature switch, DEAD CRANK switch, low oil pressure switch, oil pressure sender, governor actuator, fuel injection pump, coolant temperature sender, magnetic pickup, fuel level sender, fuel float module, and auxiliary fuel pump.
- g. Open output box access door. Remove screws (4, FIGURE 4-5) and cover (5) from AC circuit interrupter relay (40). Tag and disconnect electrical leads from cranking relay (43), current transformer (31), AC circuit interrupter relay (40), power potential transformer (37), and voltage reconnection board (18).
- h. Tag and disconnect electrical leads for droop current transformer (34) from terminal board (25).
- i. Remove screws (24) and nuts (23) securing terminal boards (25) and (26) in output box.
- j. Remove all clamps securing output box harness to generator set.
- k. Remove output box harness (27) from output box and generator set.

4-10-3 Testing.

- a. Set multimeter for ohms.
- b. Check individual wires, connectors, and terminal boards for continuity. Refer to Wiring Diagram FO-2 for wire identification.

4-10-4. Repair.

- a. Replace damaged cable assemblies, terminals, connectors, sockets, and terminal boards.
- b. Replace wires with damaged insulation and those that do not indicate continuity.

4-10-5 Installation.

- a. Position output box harness (27, FIGURE 4-5) in output box and generator set.
- b. Install all clamps, as removed, securing output box harness in generator set.
- c. Secure terminal boards (25) and (26) in output box with screws (24) and nuts (23).
- d. Connect electrical leads for droop current transformer (34) to terminal board (25) and remove tags.

- e. Connect electrical leads to AC circuit interrupter relay (40), current transformer (31), cranking relay (43), power potential transformer (37), and voltage reconnection board (18). Install cover (5) with screws (4) on AC circuit interrupter relay (40). Remove tags and close output box access door.
- f. On left side of engine connect electrical leads to auxiliary fuel pump, fuel level sender, fuel float module, magnetic pickup, coolant temperature sender, governor actuator, fuel injection pump, oil pressure sender, low oil pressure switch, DEAD CRANK switch, and coolant high temperature switch. Remove tags and close left side engine access doors.
- g. On right side of engine connect electrical leads to ether solenoid valve, starter motor, starter solenoid, and battery charging alternator. Remove tags and close right side engine access doors.
- h. Install output box top panel, paragraph 4-8-2, step j.
- i. Install control box assembly, paragraph 2-19-4.
- j. Connect negative battery cable and close battery access door.

4-11 CURRENT TRANSFORMER.

4-11-1 Removal.

- a. Shut down generator set.
- b. Open battery access door and disconnect negative battery cable.
- c. Remove control box assembly, paragraph 2-19-2
- d. Remove output box top panel, paragraph 4-8-1, step 1.
- e. Open output box and right side engine access doors.
- f. Tag and disconnect current transformer (31, FIGURE 4-5) electrical leads.
- g. Tag and disconnect main generator cables T2 and T8 from voltage reconnection board (18).
- h. Unwrap main generator cables from droop current transformer (34) and current transformer (31). Note number and direction of wraps.
- i. Remove screws (29), flatwashers (30), nuts (28), and current transformer (31) from output box.

4-11-2 Testing.

- a. Remove current transformer, paragraph 4-11-1.
- b. Set multimeter for ohms and check for continuity between secondary terminals A1 and A2, B1 and B2, and C1 and C2.
- c. If continuity is present, continue with test. If continuity is not present, current transformer is defective and must be replaced.
- d. Set up a test circuit using 10 gauge wire as shown in FIGURE 4-6. Make ten passes with wire through phase A window.
- e. Turn on power source and load bank. Adjust load bank until 27.7 amps is indicated on ammeter.
- f. Set multimeter for amperes, and connect to secondary terminals A1 and A2. Multimeter indication must be 0.9 to 1.1 amps.

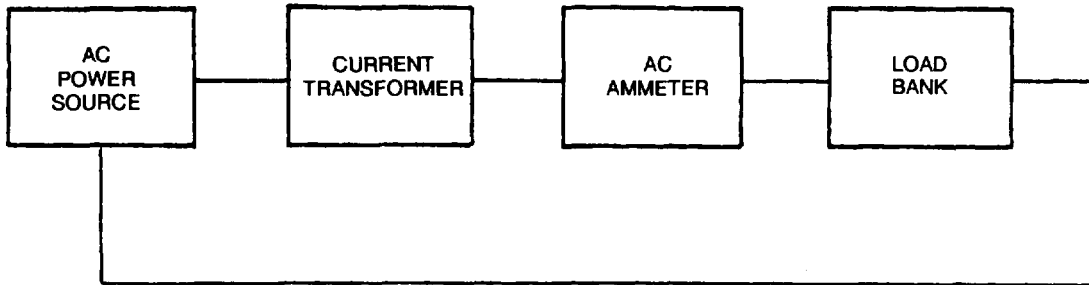

FIGURE 4-6. Testing Current Transformer

- g. Repeat steps d, e, and f using phase window B and secondary terminals B1 and B2.
- h. Repeat steps d, e, and f using phase C window and secondary terminals C1 and C2.
- i. Replace current transformer if multimeter indication in any phase is other than stated in step f.
- j. Remove current transformer from test circuit.
- k. Install current transformer, paragraph 4-11-3.

4-11-3 Installation.

- a. Install current transformer (31, FIGURE 4-5) with screws (29), flatwashers (30), and nuts (28).
- b. Wrap main generator cables around current transformer (31) and droop current transformer (34) using same number of wraps noted during removal.
- c. Connect main generator cables to voltage reconnection board (18) and remove tags.
- d. Connect electrical leads to current transformer (31) and remove tags.
- e. Close output box and right side engine access doors.
- f. Install output box top panel, paragraph 4-8-2, step j.
- g. Install control box assembly, paragraph 2-19-4.
- h. Connect negative battery cable. Close battery access door.

4-12 DROOP CURRENT TRANSFORMER

4-12-1 Removal.

- a. Shutdown generator set.
- b. Open battery access door and disconnect negative battery cable.

- c. Open output box and right side engine access doors.
- d. Tag and disconnect main generator cables T2 and T8 from voltage reconnection board (18, FIGURE 4-5).
- e. Unwrap main generator cables T2 and T8 from droop current transformer (34). Note number and direction of wraps.
- f. Tag and disconnect droop current transformer (34) electrical leads from terminal board (25).
- g. Remove screws (33), nuts (32) and droop current transformer (34) from output box.

4-12-2 Testing.

- a. Remove droop current transformer, paragraph 4-12-1.
- b. Set multimeter for ohms and check for continuity between secondary leads 1 and 2.
- c. If continuity is present, continue with test. If continuity is not present, droop current transformer is defective and must be replaced.
- d. Set up a test circuit using 10 gauge wire as shown in FIGURE 4-7. Make ten passes with wire through window of droop current transformer.
- e. Turn on power supply and load bank. Adjust load bank until 20.8 amps is indicated on AC ammeter.
- f. Set multimeter for AC amperes and connect to secondary leads 1 and 2. Multimeter indication must be between 0.9 and 1.1 amps.
- g. Replace droop current transformer if multimeter indication is other than above.
- h. Remove droop current transformer from test circuit.
- i. Install droop current transformer, paragraph 4-12-3.

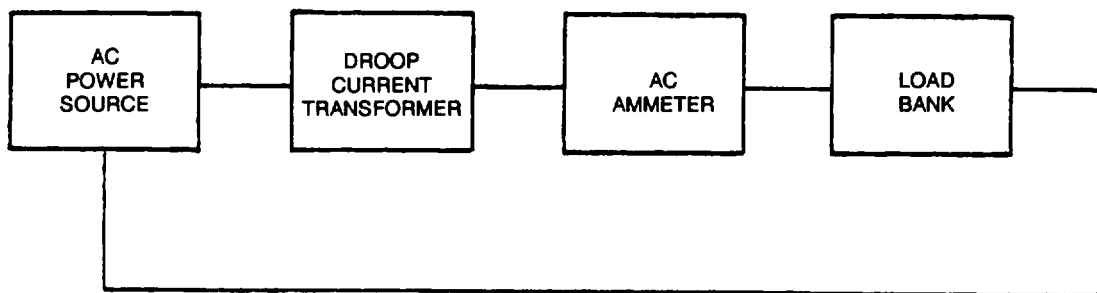

FIGURE 4-7. Testing Droop Current Transformer

4-12-3 Installation.

- a. Install droop current transformer (34, FIGURE 4-5) in output box with screws (33) and nuts (34).
- b. Wrap main generator cables around droop current transformer (34) using the same number of wraps noted during removal.
- c. Connect main generator cables to voltage reconnection board (18) and remove tags.
- d. Connect droop current transformer (34) electrical leads to terminal board (25) and remove tags
- e. Close output box and engine access doors.
- f. Connect negative battery cable and close battery access door.

4-13 POWER POTENTIAL TRANSFORMER.

4-13-1 Removal.

- a. Shut down generator set.
- b. Open battery access door and disconnect negative battery cable.
- c. Remove control box assembly, paragraph 2-19-2.
- d. Remove output box top panel, paragraph 4-8-1, step I.
- e. Tag and disconnect power potential transformer (37, FIGURE 4-5) electrical leads,
- f. Remove screws (36), nuts (35), and power potential transformer (37) from output box.

4-13-2 Testing (P/N: 17910).

- a. Remove power potential transformer, paragraph 4-13-1.
- b. Connect terminals 1 and 2 of power potential transformer to an AC power source (polarity is not important).
- c. Set power supply for 208 VAC, 60 Hz. Turn on power supply.
- d. Set multimeter for AC volts and take readings between the following terminals and compare to voltages shown:

Terminals 3 and 7=144-176 VAC
Terminals 4 and 6 = 27-33 VAC
- e. Replace power potential transformer if readings are not as voltages above.
- f. Install power potential transformer, paragraph 4-13-4.

4-13-3 Testing (P/N: A1497B).

NOTE

Used on MEP-805A only.

- a. Remove power potential transformer, paragraph 4-13-1.
- b. Connect terminals 1 and 2 of power potential transformer to an AC power source (polarity is not important).

- c. Set power supply at 208 VAC, 60 Hz. Turn on power supply.
- d. Set multimeter for AC volts and take readings between the following terminals and compare to voltages shown:
 - Terminals 5 and 6 = 54-66 VAC
 - Terminals 5 and 4 = 54-66 VAC
 - Terminals 5 and 3 = 126-154 VAC
 - Terminals 5 and 7 = 126-154 VAC
- e. Replace power potential transformer if readings are not as above.
- f. Install power potential transformer, paragraph 4-13-4.

4-13-4 Installation.

- a. Install power potential transformer (37, FIGURE 4-5) with screws (36) and nuts (35).
- b. Connect electrical leads and remove tags.
- c. Install output box top panel, paragraph 4-8-2, step j.
- d. Install control box assembly, paragraph 2-19-4.
- e. connect negative battery cable. Close battery access door.

4-14 OUTPUT BOX PANELS.

4-14-1 Inspection.

- a. Inspect output box panels (3, 46, 47, and 51, FIGURE 4-5) for cracks, dents, loose paint, corrosion, and other damage.
- b. Inspect grommets (48), (49), and (50), door seal (52), and EMI seal (53) for looseness, tears, deterioration and other damage.

4-14-2 Removal.

- a. Shutdown generator set.
- b. Open battery access door and disconnect negative battery cable.
- c. Remove control box assembly, paragraph 2-19-2.
- d. Remove generator housing rear panel, paragraph 2-18-1.
- e. Remove output box access door, paragraph 2-14-1.
- f. Remove air cleaner assembly, paragraph 2-73-3.
- g. Remove bolts (2, FIGURE 4-5), nuts (1), and output box top panel (3).
- h. Remove voltage reconnection terminal board, paragraph 4-9-1.
- i. Remove droop current transformer, paragraph 4-12-1.
- j. Remove power potential transformer, paragraph 4-13-1.
- k. Remove current transformer, paragraph 4-11-1.

- l. Remove output box harness, paragraph 4-10-2,
- m. Remove nuts (38), screws (39), and AC circuit interrupter relay (40).
- n. Remove nuts (41), screws (42), and cranking relay (43).
- o. Remove nuts (6, FIGURE 4-4), bolts (7), and output box panels from generator set.
- p. Remove bolts (45), nuts (44), and output box side panels (46) and (47) from output box bottom panel (51).
- q. Remove grommets (48), (49), and (50) from output box panels (3) and (51).
- r. If necessary, remove door seal (52) and EMI seal (53) from output box top panel (3).

4-14-3 Repair.

WARNING

Wear protective mask and gloves when sanding CARC painted surfaces. CARC paint dust is a health hazard and could cause personal injury if warning is not followed.

- a. Repair all dents and cracks, and remove all loose paint.
- b. Remove light corrosion with fine grit abrasive paper (Item 16, Appendix C).
- c. Replace damaged seals and grommets.
- d. Repaint surfaces in accordance with TM 43-0139. (F) Refer to applicable directives.

4-14-4 Installation.

- a. Install grommets (48, 49, and 50, FIGURE 4-5) in output box panels (3) and (51).
- b. Install output box side panels (46) and (47) on output box bottom panel (51) with bolts (45) and nuts (44).
- c. Install output box panels in generator set with bolts (7) and nuts (6).
- d. Install cranking relay (43) with screws (42) and nuts (41).
- e. Install AC circuit interrupter relay (40) with screws (39) and nuts (38).
- f. Install current transformer, paragraph 4-11-3.
- g. Install power potential transformer, paragraph 4-13-4.
- h. Install droop current transformer, paragraph 4-12-3.
- i. Install voltage reconnection terminal board, paragraph 4-9-2.
- j. Install output box harness, paragraph 4-10-5.
- k. Install air cleaner assembly, paragraph 2-73-4.
- l. Install output box top panel (3) with bolts (2) and nuts (1).
- m. If removed, install self-adhesive door seal (52), and EMI seal (53) with adhesive (Item 1, Appendix C) on output box top panel (3).

- n. Install output box access door, paragraph 2-14-4.
- o. Install generator housing rear panel, paragraph 2-18-4.
- p. Install control box assembly, paragraph 2-19-4.
- q. Connect negative battery cable and dose battery access door.

Section V. MAINTENANCE OF ENGINE ACCESSORIES

4-15 GOVERNOR ACTUATOR.

4-15-1 Testing.

- a. Shut down generator set.
- b. Open battery access door and disconnect negative battery cable.
- c. Open left side engine access doors and disconnect connector (1, FIGURE 4-8) from engine electrical harness.
- d. Connect 5 ohm, 25 watt resistor in series with pin 2 of connector (1) and ground.
- e. Connect jumper wire from pin 1 of connector (1) to battery positive terminal (24 VDC).
- f. Connect negative battery cable. Governor actuator (11) shaft should extend to full fuel position.
- g. Disconnect negative battery cable. Governor actuator shaft should retract to no fuel position.
- h. Replace governor actuator if it does not function as above.
- i. Remove resistor and jumper wire from connector (1), ground, and battery.
- j. Connect connector (1) to engine electrical harness and close left side engine access doors.
- k. Connect negative battery cable and dose battery access door.

4-15-2 Removal.

- a. Shut down generator set.
- b. Open battery access door and disconnect negative battery cable.
- c. Open left side engine access doors and remove DEAD CRANK switch, paragraph 2-111-2.
- d. Tag and disconnect connector (1, FIGURE 4-8) from electrical harness.
- e. Remove nuts (2) and (3) bolt (4) and rod assembly (5) from fuel injection pump lever and clevis (7).

NOTE

Count number of turns required to remove clevis (7) for initial adjustment during installation.

- f. Loosen nut (6) and unscrew clevis (7) from governor actuator shaft.

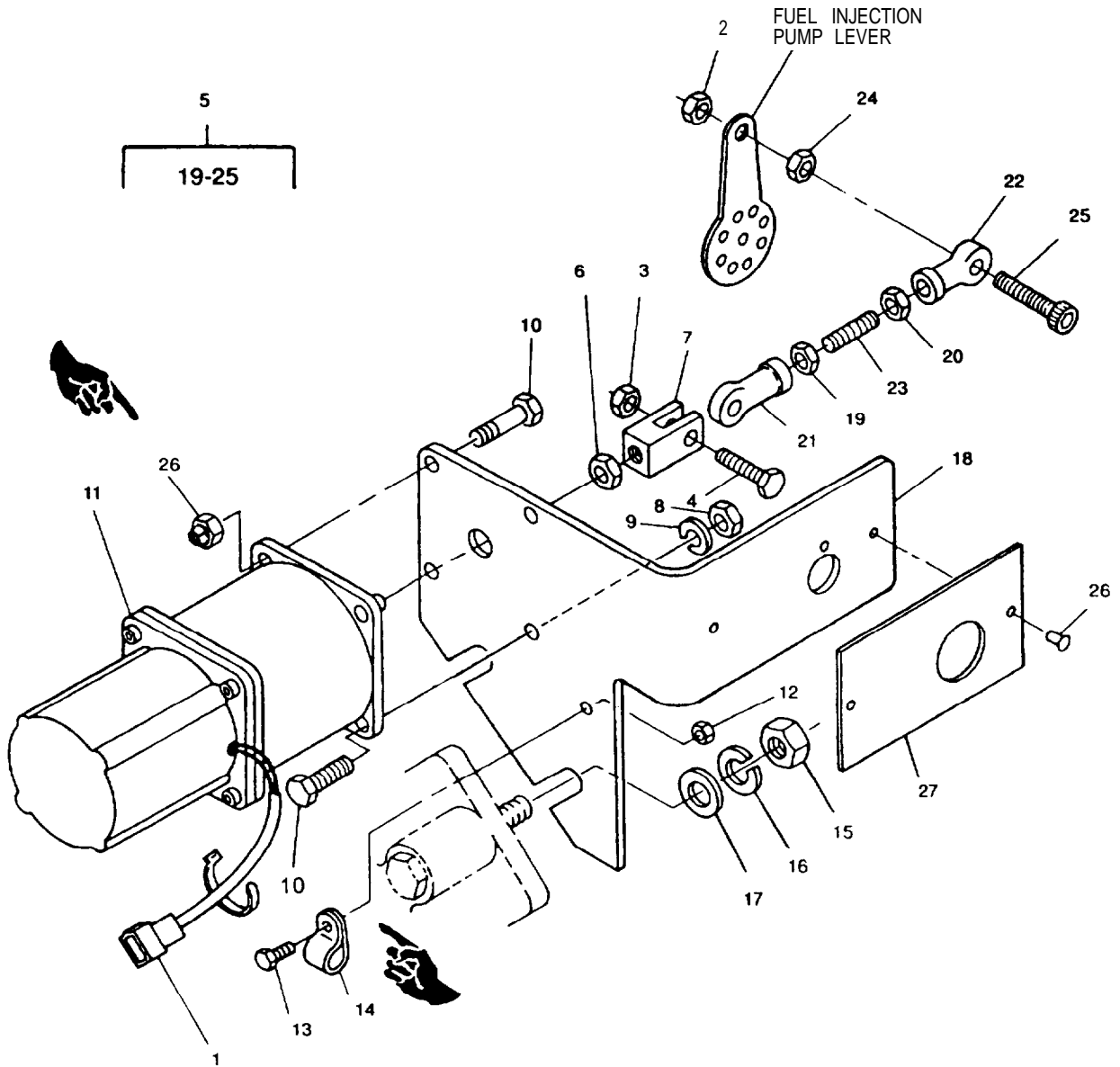

FIGURE 4-8. Governor Actuator Assembly

- g. Remove nuts (8, 28) lockwashers (9) bolts (10), and governor actuator (11) from mounting bracket (18).
- h. Remove nut (12), bolt (13), and clamp (14) securing electrical wiring to mounting bracket (18).
- i. Remove nuts (15), lockwashers (16,) washers (17), and mounting bracket (18) from front cover mounting bolts.

NOTE

Count number of turns required to separate rod ends for initial adjustment during installation.

- j. If necessary, disassemble rod assembly (5) by loosening nuts (19) and (20) and unscrewing rod ends (21) and (22) from rod (23).
- k. If necessary, remove nut (24) and bolt (25) from rod end (22).
- l. If necessary, drill out rivets (26) and remove identification plate (27) from bracket (18).

4-15-3 Installation.

- a. If disassembled, screw rod ends (21 and 22, FIGURE 4-8) onto rod (23) the same number of turns noted on disassembly, and tighten nuts (19) and (20) finger tight only.
- b. If removed, install bolt (25) and nut (24) into rod end (22).
- c. If removed, install identification plate (27) on bracket (18) with rivets (26).
- d. Install mounting bracket (18) on front cover mounting bolts with washers (17) lockwashers (16) and nuts (15).
- e. Secure electrical wiring to mounting bracket (18) with clamp (14), bolt (13). and nut (12).
- f. Install governor actuator (11) on mounting bracket (18) with bolts (10), lockwashers (9) and nuts (8, 28).
- g. Screw clevis (7) on governor actuator shaft the same number of turns noted on disassembly, and tighten nut (6) finger tight only.
- h. Install rod assembly (5) on injection pump lever and clevis (7) with bolt (4) and nuts (2) and (3).
- i. Install DEAD CRANK switch, paragraph 2-111-3.
- j. Connect connector (1) to engine harness and remove tag.
- k. Connect negative battery cable and close battery access door.
- l. Adjust governor actuator in accordance with paragraph 4-15-4 .

4-15-4 Adjustment.

- a. Tag and disconnect connector (1, FIGURE 4-7) from engine harness.
- b. Remove nut(2) and disconnect rod assembly (5).
- c. Manually move fuel injection pump lever to full fuel position.
- d. Start generator set while holding fuel injection pump lever in position.
- e. Slowly move fuel injection pump lever toward no fuel position until generator set shuts down.

- f. Mark position of fuel injection pump lever on engine block at exact no fuel (shut down) point. Measure injection pump lever center line position to mounting surface of actuator. Refer to FIGURE 4-9.
- g. Adjust rod assembly (5) and clevis (7) as necessary so that center line of fuel injection pump lever when connected and measured as in step f, will be positioned past the no fuel point by 0.125 to 0.25 inch (3.17 to 6.35 mm). Tighten nuts (6), (19), and (20).
- h. Install rod assembly (5) on fuel injection pump lever with nut (2).
- i. Connect connector (1) to engine harness.
- j. Start generator set, check generator performance and adjust governor control unit as necessary in accordance with paragraph 4-3-3 .

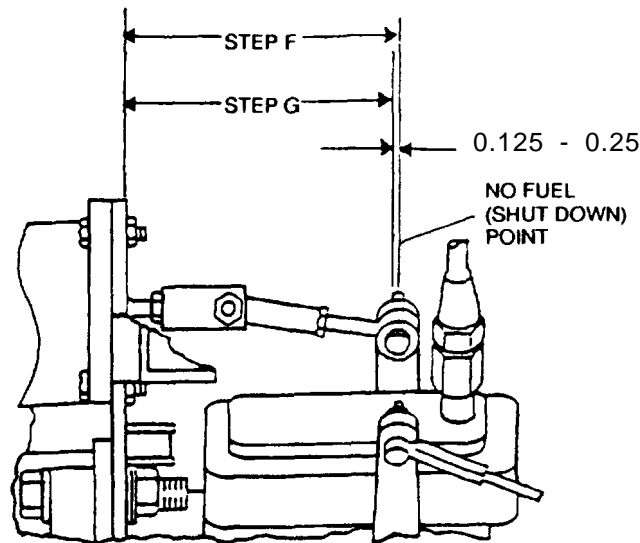

FIGURE 4-9. Governor Actuator Adjustment

Section VI. MAINTENANCE OF GENERATOR ASSEMBLY

NOTE

Maintenance procedures for the 50/60 Hz (MEP805A) and 400 Hz (MEP815A) generators are identical except where noted.

4-16 TECHNICAL DESCRIPTION.

4-16-1 General. Revolving field type generators have a DC field revolving within a stationary AC winding called the stator. AC power is distributed from the generator through leads connected to the stator windings. There are no sliding contacts between the AC winding and the load, therefore, great amounts of power may be drawn from this generator.

NOTE

Refer to FIGURE 4-10 as needed.

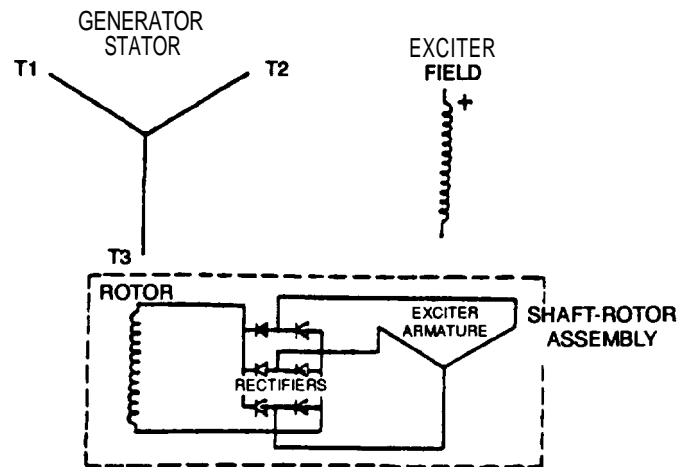

FIGURE 4-10. Brushless Generator Schematic

To energize the field, DC excitation must be applied to the generator field coils. The excitation current is supplied from a brushless exciter mounted on the generator shaft.

The brushless exciter is actually an AC generator with its output rectified through a full wave bridge circuit. This type of brushless exciter will provide the necessary excitation current. The generator set field flash circuit, activated during each engine start, applies voltage to the exciter stator to begin the voltage build-up process to energize the generator field.

The generator output voltage is controlled by controlling the alternating field current. This is accomplished by regulating the exciter field coil voltage. The exciter field coil voltage is regulated with a solid-state-type voltage regulator.

4-16-2 Damper Bars are inserted through the field laminations and welded at the end to a solid copper plate. The damper windings provide stable parallel operation, reduce damping current losses, and limit the increase of third harmonic voltage with increase in load.

4-16-3 Brushless Exciter The brushless exciter consists of an armature with a three-phase AC winding and rotating rectifier assembly within a stationary field.

The stationary exciter field assembly is mounted in the main generator frame. The exciter armature is press fit and keyed onto the shaft assembly. The rotating rectifier assembly slides over the bearing end of the generator rotor shaft and is secured with bolts and washers to an adapter hub which is shrunk on the generator shaft.

4-16-4 Rotating Rectifier Bridge. The rotating rectifier bridge consists of rectifying diodes mounted on a brass heat sink which is in turn mounted on an insulating ring. The entire assembly bolts to the adapter on the generator shaft. Therefore, the rotating rectifier assembly will rotate with the exciter armature eliminating the need for any sliding contacts between the exciter output and the alternator field.

4-16-5 Exciter Field. The exciter field on the high frequency exciter consists of laminated segments of high carbon steel which are fitted together to make up the field poles. The field coils are placed into the slots of the field poles.

4-16-6 Exciter Field Coil Voltage Source. Field coil DC voltage is obtained by rectifying the voltage from a phase to neutral line of the generator output, or other appropriate terminal to provide the needed voltage reference.

The rectifier bridge is an integral part of the static regulator. The static regulator senses a change in the generator output and automatically regulates current flow in the exciter field coil circuit to increase or decrease the exciter field strength. An external adjust rheostat sized to be compatible with the regulator is used to provide adjustment to the regulator sensing circuit.

4-16-7 Balance. The rotor assembly is precision balanced to a high degree of static and dynamic balance. Balance is achieved with the balance lugs on the field pole tips. The balance will remain dynamically stable at speed in excess of the design frequencies.

4-16-8 Bearing. The generator rotor assembly is suspended on shielded, factory lubricated ball bearings. They are greased for life and do not require lubrication.

4-16-9 Stator Assembly. The stator assembly consists of laminations of steel mounted in a rolled steel frame. Random wound stator coils are fitted into the insulated slots.

WARNING

Make sure unit is completely shut down and free of any power source before attempting any repair or maintenance on the unit. Failure to follow this procedure could result in injury or death by electrocution.

4-17 GENERATOR ASSEMBLY

4-17-1 Removal.

- a. Shut down generator set.
- b. Open battery access door and disconnect negative battery cable.
- c. Remove output box assembly, paragraph 4-8-1.
- d. Remove generator set rear housing section, paragraph 2-18-1.
- e. Loosen bolts (1, FIGURE 4-11) and lower engine support brackets (2) to contact skid base. Tighten bolts (1). If necessary, place wooden shim under bracket to ensure contact.

CAUTION

Rated capacity of overhead hoist should be at least 1000 pounds (454 kg).

- f. Attach lifting harness to overhead hoist and generator lifting eye, and take up slack
- g. Remove nuts (3), lockwashers (4), washers (6), screws (5) and screen/cover (7) from generator case.
- h. Remove bolts (8) and lockwashers (9) securing generator disc drive to engine flywheel.
- i. Remove bolts (11) and lockwashers (13) securing generator to flywheel housing.
- j. Remove nuts (14), washers (15), snubbing washers (16, bolts (18) and bellville washers (17) securing generator to skid base.
- k. Lift generator slowly from skid base, ensuring that engine flywheel housing and generator separate smoothly avoiding any undue stress.
- l. Remove shock mounts (19) from skid base.
- m. Remove nuts (20), washers (21), bolts (10), angles (24), and plates (12) from generator.

4-17-2 Installation.

- a. Position generator shock mounts (19, FIGURE 4-11) in skid base.

4-32 **Change 1**

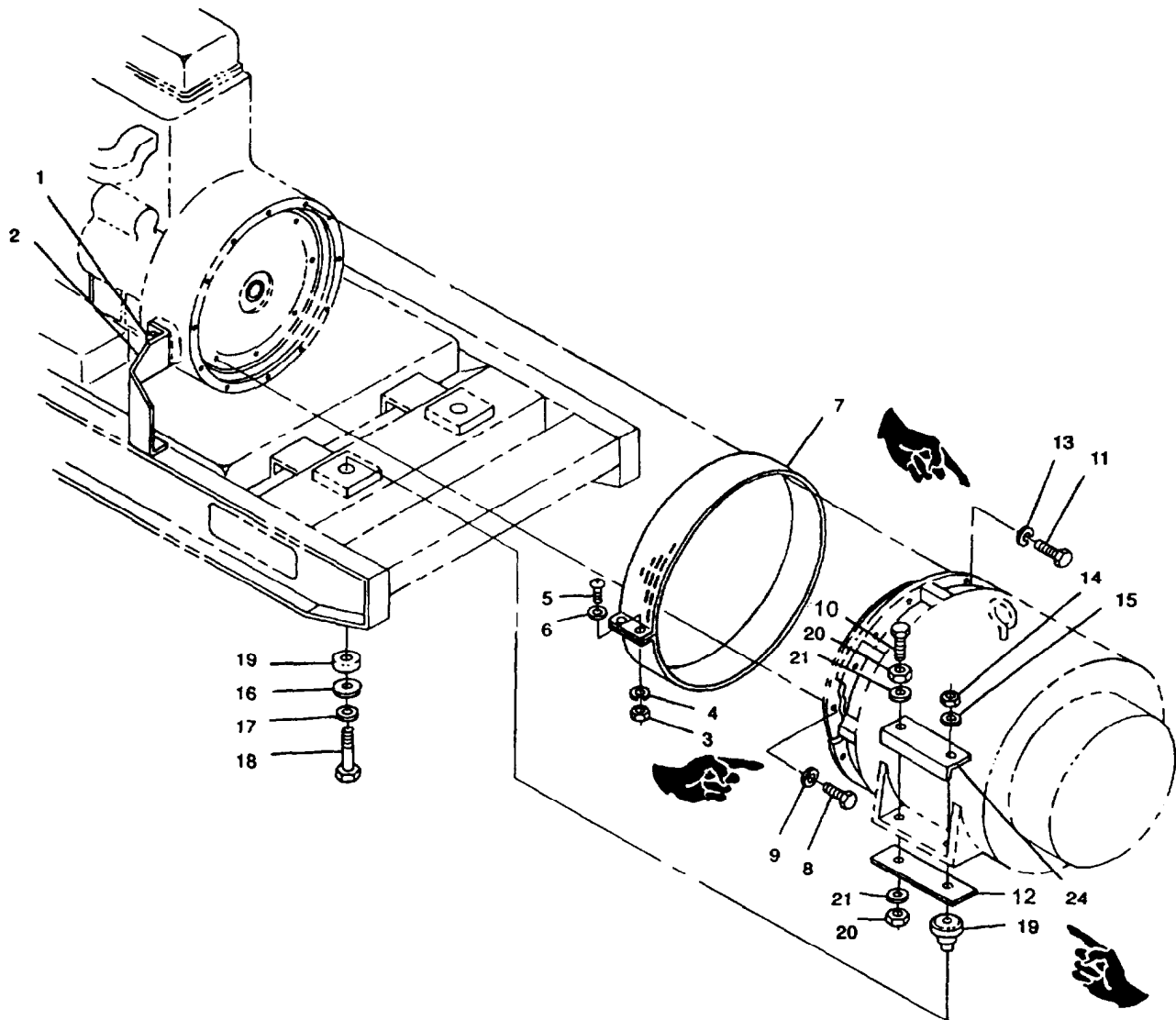

FIGURE 4-11. Generator Assembly Removal

- b. Install angles (24) and plates (12) on generator with bolts (10), washers (21), and nuts (20).

CAUTION

Rated capacity of overhead hoist should be at least 1000 pounds (454 kg).

- c. Attach lifting harness to overhead hoist and generator lifting eye.
- d. Position generator on skid base aligning mounting holes with mounts and engine flywheel housing.
- e. Install bolts (11) and lockwashers (13), tightening bolts (11) slowly to ensure even and proper seating of generator housing lip to flywheel housing.

ARMY TM 9-6115-644-24
AIR FORCE TO 35C2-3-446-12
MARINE CORPS TM 0924A/09246A-24/2

- f. Install bolts (18), bellville washers (17), snubbing washers (16), washers (15) and nuts (14) securing generator assembly to skid base. Torque nuts (14) to 210 ft-lbs (265 Nm).
- g. Align scribe mark on generator drive disc and engine flywheel, and install bolts (8) and lockwashers (9) securing generator drive disc to engine flywheel.
- h. Install screen/cover (7) on generator case with screws (5), washers (6), lockwashers (4) and nuts (3).
- i. Adjust nuts (20) on generator mount to obtain 0.5 in. Minimum clearance between ends of bolts (10) and skid base.
- j. Install generator set rear housing section, paragraph 2-18-4.
- k. Install output box assembly, paragraph 4-8-2.
- l. Connect negative battery cable and close battery access door.
- m. Start generator set and check for proper operation.

4-18 ROTATING RECTIFIER DIODES.

4-18-1 Testing.

- a. Shut down generator set. Allow generator to cool to ambient temperature.
- b. Open battery access door and disconnect negative battery cable.
- c. Remove generator set housing rear panel, paragraph 2-18-1.
- d. Remove generator end bell cover plates, paragraph 4-19-1, step d.

NOTE

It will be necessary to bar (turn) engine in order to position a specific area of the rotating rectifier at one of the end bell access holes. Use center bolt on harmonic balancer to turn engine, refer to TM 9-2815-255-24.

- e. Remove nuts (1, FIGURE 4-12) and lockwashers (2) from rotating rectifier terminals.
- f. Tag and remove main rotor and diode leads from rotating rectifier terminals.
- g. Tag exciter rotor leads and remove bolts (3), washers (4), and exciter rotor leads from rectifier mounting plate assemblies.
- h. Set multimeter for ohms and connect positive lead to one side and negative lead to other side of each diode (6). Record multimeter reading for each diode.
- i. Repeat step h, with multimeter leads reversed.
- j. Resistance (ohms) readings should be low in one direction and high in reversed direction. If readings are high or low in both directions, diode is defective and must be replaced.
- k. Install diode and main rotor leads to rotating rectifier terminals with nuts (1) and lockwashers (2). Remove tags.
- l. Install exciter rotor leads to rectifier mounting plate assemblies with washers (4) and bolts (3). Remove tags.
- m. Install generator end bell cover plates, paragraph 4-19-2, step 1.

4-34 Change 1

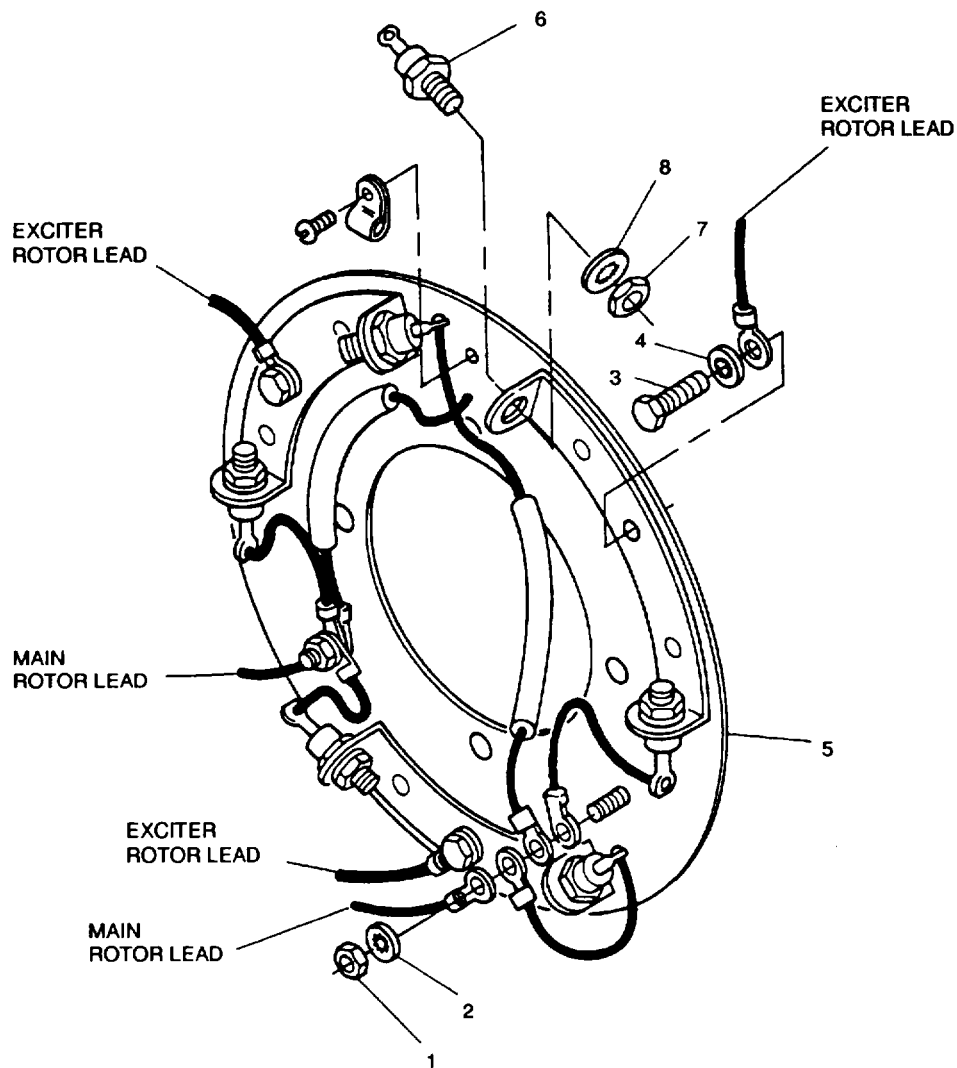

FIGURE 4-12. Rectifier Assembly

- n. Install generator set housing rear panel, paragraph 2-18-4.
- o. Connect negative battery cable and close battery access door.

4-18-2 Removal.

- a. Shut down generator set.
- b. Open battery access door and disconnect negative battery cable.
- c. Remove generator set housing rear panel, paragraph 2-18-1.
- d. Remove end bell top cover and louvered covers, paragraph 4-19-1, step d.

NOTE

It will be necessary to bar (turn) engine in order to position a specific area of the rotating rectifier at one of the end bell access holes. Use center bolt on harmonic balancer to turn engine, refer to TM9-2815-255-24.

- e. Unsolder electrical lead from diode (6, FIGURE 4-12) being removed.
- f. Remove nut (7), lockwasher (8), and diode (6) from rotating rectifier assembly through access hole in end bell.

4-18-3 Installation.

- a. Run bead of thermal-electrical contact compound (Item 9, Appendix C) around base of diode (6, FIGURE 4-12) prior to installing. Do not coat threads.
- b. Insert diode (6) through generator end bell access hole, and install on rotating rectifier plate with lockwasher (8) and nut (7). Torque nut (7) 28 to 30 in-lbs. (3.16 to 3.38 Nm).
- c. Using solder (Item 19, Appendix C) and soldering iron, solder electrical lead to diode (6).
- d. Install generator end bell top cover and louvered covers, paragraph 4-19-2, step f.
- e. Install generator set housing rear panel, paragraph 2-18-4.
- f. Connect negative battery cable and close battery access door.

4-19 END BELL AND MAIN BEARING.

4-19-1 Removal.

- a. Shutdown generator set.
- b. Open battery access door and disconnect negative battery cable.
- c. Remove generator set housing rear panel, paragraph 2-18-1.
- d. Remove bolts (1, FIGURE 4-14), lockwashers (2), top cover (3), and louvered covers (4) from end bell (5).

CAUTION

The end bell supports the main rotor, thus the rotor will drop on the stator once the end bell is removed. Prior to proceeding, bar engine by using center bolt on harmonic balancer, TM 9-2815-255-24, until two main rotor poles are vertical in generator stator. Having the rotor in this position will limit the amount of drop, otherwise damage to rotor and/or stator could occur.

- e. Remove bolts (6) and lockwashers (7) from end bell (5).
- f. Install two bolts (6) in "backout" holes in end bell flange, refer to FIGURE 4-13.
- g. Loosen lead clamp assembly (33, FIGURE 4-14) damping generator leads at side of generator housing. Ensure that wires F1 and F2 are free to slide in and out of generator housing.
- h. Remove end bell (5), with exciter stator (16) attached, by tightening bolts (6) evenly into "back-out" holes.
- i. Remove preformed packing (9) from end bell (5).

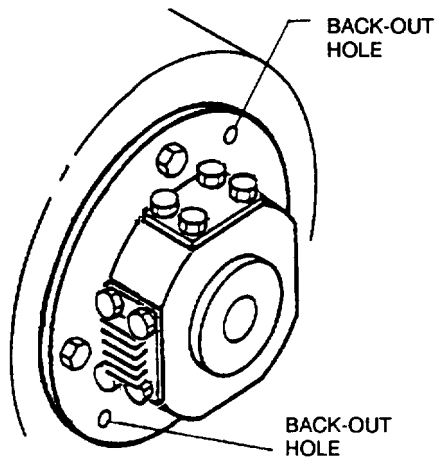

FIGURE 4-13. End Bell Removal

CAUTION

If bearing needs to be removed for any reason, always install new bearing. Main bearing is easily damaged when removed from rotor shaft. Damage to equipment could result.

- j. Using bearing puller, remove bearing (8) from main rotor shaft (10).

4-19-2 Installation.

CAUTION

If bearing needs to be removed for any reason, always install new bearing. Main bearing is easily damaged when removed from rotor shaft. Damage to equipment could result.

- a. Install bearing (8, FIGURE 4-14). Ensure that bearing is seated squarely against shaft (10) shoulder by applying pressure to inner race only.
- b. Install preformed packing (9) in end bell (5).
- c. Position bearing (8) in end bell (5).

NOTE

It may be necessary to use a lifting device to raise and align end bell (5) with generator housing (11).

- d. Position end bell (5), with exciter stator(16) attached, on generator housing (11) while pulling slack of wires F1 and F2 through side of generator housing. Secure end bell (5) with bolts (6) and lockwashers (7). Torque bolts (6) 59 to 61 in-lbs (6.7 to 7 Nm).
- e. Tighten lead damp assembly (33) at side of generator housing ensuring that generator leads are damped securely.
- f. Install top cover (3) and louvered covers (4) on end bell (5) with bolts (1) and lockwashers (2).

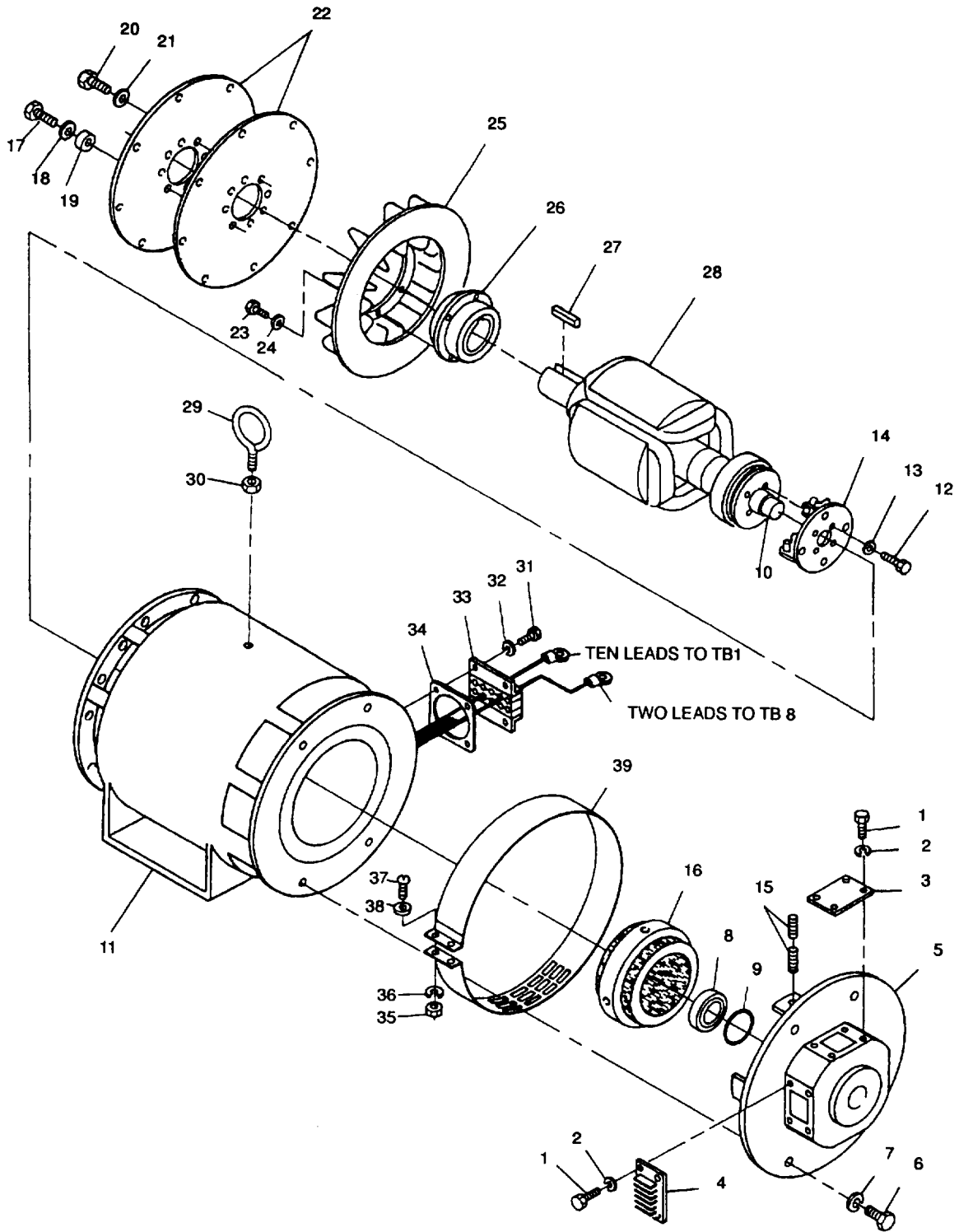

FIGURE 4-14. Generator Assembly

- g. Install generator set housing rear panel, paragraph 2-18-4.
- h. Connect negative battery cable. Close battery access door.

4-20 ROTATING RECTIFIER.

4-20-1 Removal.

- a. Shutdown generator set.
- b. open battery access door and disconnect negative battery cable.
- c. Remove generator set housing rear panel, paragraph 2-18-1.
- d. Remove generator end bell and main bearing, paragraph 4-19-1.
- e. Remove bolts (3, FIGURE 4-12) and lockwashers (4) securing exciter rotor leads (3 places) to rotating rectifier. Tag and remove exciter rotor leads.
- f. Remove nuts (1), lockwashers (2), tag and remove main rotor leads and rotating rectifier diode leads.
- g. Remove bolts(12, FIGURE 4-13), lockwashers (13) and rotating rectifier (14) from rotor assembly (28).

4-20-2 installation.

- a. Install rotating rectifier (14, FIGURE 4-14) on rotor assembly (28) with bolts (12) and lockwashers (13).
- b. Connect two main rotor leads and rotating rectifier diode leads with lockwashers (2, FIGURE 4-12) and nuts (1).
- c. Connect three exciter rotor leads to rotating rectifier with bolts (3) and lockwashers (4).
- d. Install main bearing and generator end bell, paragraph 4-19-2
- e. install generator set housing rear panel, paragraph 2-18-4.
- f. Connect negative battery cable. Close battery access door.

4-21 Exciter Stator.

4-21-1 Testing.

- a. Shutdown generator set. Allow generator to cool to ambient temperature.
- b. Open battery access door and disconnect negative battery cable.
- c. Open output box access door and disconnect exciter field leads F1 and F2 from terminals 1 and 2 of TB8.
- d. Set multimeter for ohms and connect between disconnected exciter field leads. Multimeter reading should be as shown in TABLE 4-3.
- e. Multimeter reading other than in TABLE 4-3, indicates open or shorted windings and exciter stator must be replaced.
- f. Connect multimeter between each exciter field lead and generator frame in turn.
- g. Multimeter reading of less than infinity indicates defective ground insulation and exciter stator must be replaced.
- h. Connect exciter field leads to terminals 1 and 2 of TB8 and Close output box access door.

- i. Connect negative battery cable and close battery access door.

4-21-2 Removal.

- a. Shutdown generator set.
- b. Open battery access door and disconnect negative battery cable.
- c. Remove generator set housing rear panel, paragraph 2-18-1.
- d. Open output box access door and disconnect exciter field leads F1 and F2 from terminals 1 and 2 of TB8.
- e. Attach "fish wires" to disconnected F1 and F2 leads to aid in installation process.
- f. Remove generator end bell, paragraph 4-19-1.
- g. Remove setscrews (15, FIGURE 4-14) and exciter stator (16) from end bell (5).
- h. Detach "fish wires" once F1 and F2 leads clear generator housing (11).

4-21-3 Installation.

- a. Attach "fish wires" to F1 and F2 leads of exciter stator (16, FIGURE 4-14).
- b. Gently pull on "fish wires" to pull F1 and F2 leads back through generator housing. Disconnect "fish wires" and position F1 and F2 leads in output box.
- c. Position exciter stator (16) in end bell (5). Secure exciter stator (16) in place with setscrews (15).
- d. Install generator end bell, paragraph 4-19-2.
- e. Install generator set housing rear panel, paragraph 2-18-4.
- f. Connect exciter field leads F1 and F2 to terminals 1 and 2 of TB8. Close output box access door.
- g. Connect negative battery cable and close battery access door.

4-22 EXCITER ROTOR.

4-22-1 Testing.

- a. Shutdown generator set. Allow generator to cool to ambient temperature.
- b. Open battery access door and disconnect negative battery cable.
- c. Remove generator set housing rear panel, paragraph 2-18-1.
- d. Remove generator end bell top cover and louvered covers, paragraph 4-19-1, step d.
- e. Tag and disconnect exciter rotor leads (3 places) from rotating rectifier by removing bolts (3, FIGURE 4-12) and lockwashers (4).

NOTE

It will be necessary to bar (turn) the engine in order to position a specific area of the rotating rectifier at one of the end bell access holes. Turn engine using center bolt on harmonic balancer, refer to TM9-2815-255-24.

Connect resistance bridge, between two exalter rotor leads and note resistance reading. Continue this procedure until readings are noted for each combination of leads (i.e., 1 and 2, 1 and 3, and 2 and 3).

TABLE 4-3. Generator Resistance Values At 25°C (77°F)

Component	Resistance	
	MEP-805A	MEP-815A
Exalter Stator	Between 24.85 & 33.61 ohms	Between 24.9693 & 33.7819 ohms
Exalter Rotor	Between 0.202 & 0.274 ohms	Between 0.2061 & 0.2787 ohms
Generator Rotor	Between 1.03 & 1.51 ohms	Between 1.9874 & 2.6888 ohms
Generator Stator	Between 0.0736 & 0.0994 ohms	Between 0.0306 & 0.0412 ohms

NOTE

Ambient temperature must be expressed in °C. To convert °C to °F use: °F = °C x 9 ÷ 5 + 32

- 1) To determine the resistance values at current ambient temperature, use the following formula:

$$R_1 = R_{25} [1 + 0.00385 (T-25)]$$

Where:

- R₁ = Unknown resistance
- R₂₅ = Known resistance at 25°C (77° F)
- T = Current ambient temperature

- 2) Example for exalter stator leads at 5°C (41 °F):

$$R_1 = 29.23 [1 + 0.00385 (5-25)]$$

$$R_1 = 29.23 [1 + 0.00385 (-20)]$$

$$R_1 = 29.23 [1 + -0.077]$$

$$R_1 = 29.23 [0.923]$$

$$R_1 = 26.98 \pm 15\% \text{ ohms}$$

- g. Resistance readings should be as shown in TABLE 4-3 for each combination of leads. Readings other than in TABLE 4-3, indicate open or shorted windings and exalter rotor must be replaced.
- h. Set multimeter for ohms and connect between each exalter rotor lead and end bell in turn.
- i. Multimeter reading of less than infinity indicates defective ground insulation and exalter rotor must be replaced.
- j. Connect exalter rotor leads to rotating rectifier with lockwashers (4, FIGURE 4-12) and bolts (3). Remove tags.
- k. Install end bell top cover and louvered covers, paragraph 4-19-2, step f.
- l. Install generator set housing rear panel, paragraph 2-18-4.
- m. Connect negative battery cable and dose battery access door.

4-23 GENERATOR ASSEMBLY.

4-23-1 Testing.

- a. Shutdown generator set. Allow generator to cool to ambient temperature.
- b. Open battery access door and disconnect negative battery cable.
- c. Remove generator set housing rear panel, paragraph 2-18-1.
- d. Remove generator end bell cover plates, paragraph 4-19-1, step d.
- e. Tag and disconnect main rotor leads (2 places) from rotating rectifier by removing nuts (1, FIGURE 4-12) and lockwashers (2).

NOTE

It will be necessary to bar (turn) engine in order to position a specific area of the rotating rectifier at one of the end bell access holes. Turn engine using center bolt on harmonic balancer, refer to TM 9-2815-255-24.

- f. Set multimeter for ohms and connect between disconnected main rotor leads. Multimeter reading should be as shown in TABLE 4-3.
- g. Reading other than in TABLE 4-3, indicates shorted or open windings and main rotor must be replaced.
- h. Connect multimeter between each main rotor lead and end bell in turn.
- i. Multimeter reading of less than infinity indicates defective ground insulation and main rotor must be replaced.
- j. Connect main rotor leads to rotating rectifier with nuts (1, FIGURE 4-12) and lockwashers (2). Remove tags.
- k. Install generator end bell top cover and louvered covers, paragraph 4-19-2, step f.
- l. Install generator set housing rear panel, paragraph 2-18-4,
- m. Connect negative battery cable and close battery access door.

4-23-2 Removal.

- a. Shutdown generator set.
- b. Remove generator assembly from generator set, paragraph 4-17-1.

NOTE

Mark location of spacers (19), washers (18), and bolts (17) to ensure correct positioning during installation.

- c. Remove bolts (17 and 20, FIGURE 4-14), washers (18) and (21), spacers (19), and drive discs (22) from drive hub (26).
- d. Remove bolts (23), lockwashers (24), and fan (25) from drive hub (26).

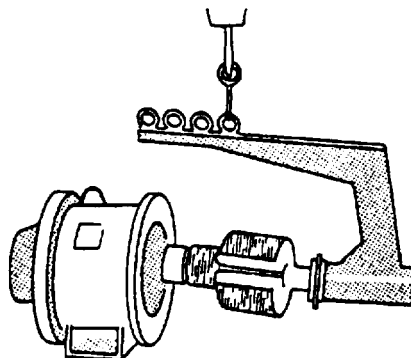

FIGURE 4-15. Rotor Assembly Lifting Device Typical)

- e. Attach a suitable rotor lifting device to drive hub (26) and overhead hoist as shown in FIGURE 4-15.
- f. Remove generator end bell, paragraph 4-19-1.

CAUTION

Special care should be taken when removing rotor assembly, winding damage could result if rotor is allowed to hit main stator.

- g. Carefully remove rotor assembly (28) and attached components from main stator and generator housing (11).
- h. Remove main bearing, paragraph 4-19-1.
- i. Remove rotating rectifier, paragraph 4-20-1.
- j. Using bearing puller, remove drive hub (26) and key (27) from rotor assembly (28).

4-23-3 Installation.

- a. Place key (27, FIGURE 4-14) on rotor assembly (28) and install drive hub (26) over key (27) and onto main rotor assembly (28).
- b. Install rotating rectifier, paragraph 4-20-2,
- c. Install main bearing, paragraph 4-19-2.

CAUTION

Special care must be taken installing rotor assembly, winding damage could result if rotor is allowed to hit main stator.

- d. Attach a suitable rotor lifting device to drive hub (26) and overhead hoist as shown in FIGURE 4-15.
- e. Carefully install rotor assembly (28) and attached components into main stator and generator housing (11).
- f. Install generator end bell, paragraph 4-19-2 and remove rotor lifting device.
- g. Install fan (25) on drive hub (26) with lockwashers (24) and bolts (23).

NOTE

Make sure all disc mounting holes at the inner and outer diameters are properly aligned.

NOTE

Ensure correct positioning of spacers (19), washers (18), and bolts (17) as marked on removal.

- h. Install drive discs (22) on drive hub (26) with spacers (19), washers (18) and (21), and bolts (17) and (20). Torque bolts (20) to 28 ft-lbs (38 Nm) and bolts (17) to 35 ft-lbs (47 Nm)
- i. Install generator assembly in generator set, paragraph 4-17-2.

4-24 GENERATOR MAIN STATOR AND HOUSING.

4-24-1 Testing.

- a. Shut down generator set. Allow generator to cool to ambient temperature.
- b. Open battery access door and disconnect negative battery cable.
- c. Remove protective cover and moveable terminal board from voltage reconnection terminal board, paragraph 2-96-2.
- d. Disconnect two electrical connectors from bottom of control box assembly.
- e. Tag and disconnect wires 107C and 109J from terminals 1 and 2 of power potential transformer (37, FIGURE 4-5).
- f. Connect resistance bridge and note readings between terminals T1 and T4, T2 and T5, T3 and T6, T7 and T0, T8 and T0, and T9 and T0 of AC voltage reconnection terminal board.
- g. All resistance readings should be as shown in TABLE 4-3.
- h. If resistance is low, there are shorted windings, if resistance is high, stator windings are open. In either case, stator must be replaced.
- i. Disconnect removable grounding link on load output terminal board (17, FIGURE 2-29).
- j. Set multimeter for ohms and connect between each coil lead and ground, in turn.
- k. If multimeter indicates resistance on any connection, stator windings are grounded and stator must be replaced.
- l. Connect removable grounding link on load output terminal board.
- m. Connect wires 107C and 109J to terminals 1 and 2 of power potential transformer. Remove tags.
- n. Connect two electrical connectors to bottom of control box assembly.
- o. Install moveable terminal board and protective cover on voltage reconnection terminal board, paragraph 2-96-3.
- p. Connect negative battery cable and close battery access door.

4-24-2 Removal.

- a. Shutdown generator set.
- b. Remove generator assembly from generator set, paragraph 4-17-1.
- c. Remove generator rotor assembly, paragraph 4-23-2.
- d. Remove lifting eye (29, FIGURE 4-14) and nut (30) from generator housing (11).
- e. Remove bolts (31), lockwashers (32), lead damp assembly (33), and gasket (34) from generator housing (11).
- f. Remove nuts (35), lockwashers (36), screws (37), washers (38), and cover/screen (39) from generator housing (11).

4-24-3 Installation.

- a. Install generator rotor assembly, paragraph 4-23-3.
- b. Install cover/screen (39, FIGURE 4-14) on generator housing (11) with screws (37), washers (38), lockwashers (36), and nuts (35).
- c. Install gasket (34) and lead clamp assembly (33) on generator housing (11) with bolts (31) and lockwashers (32).
- d. Install lifting eye (29) in generator housing (11) and tighten nut (30).
- e. Install generator assembly in generator set, paragraph 4-17-2.

Section VII. MAINTENANCE OF SKID BASE

4-25 SKID BASE.

4-25-1 Removal.

- a. Shut down generator set.
- b. Remove engine and generator assembly, paragraph 3-6-1.
- c. Remove fuel tank, paragraph 4-7-2.
- d. Remove nuts (1, FIGURE 4-16), lockwashers (2), bolts (3), washers (4), and forklift guides (5) from skid base.
- e. Remove cable grommets (6) and (7) from skid base.

4-25-2 Repair. Repair of the skid base will be limited to corrosion control and spot welding minor cracks. If major structural damage to the skid base has occurred, replace the skid base.

4-25-3 Installation.

- a. Install fork lift guides (5, FIGURE 4-16) in skid base with bolts (3), washers (4), lockwashers (2), and nuts (1).
- b. Install cable grommets (6) and (7) in skid base.
- c. Install fuel tank, paragraph 4-7-3.
- d. Install engine and generator assembly, paragraph 3-6-2.

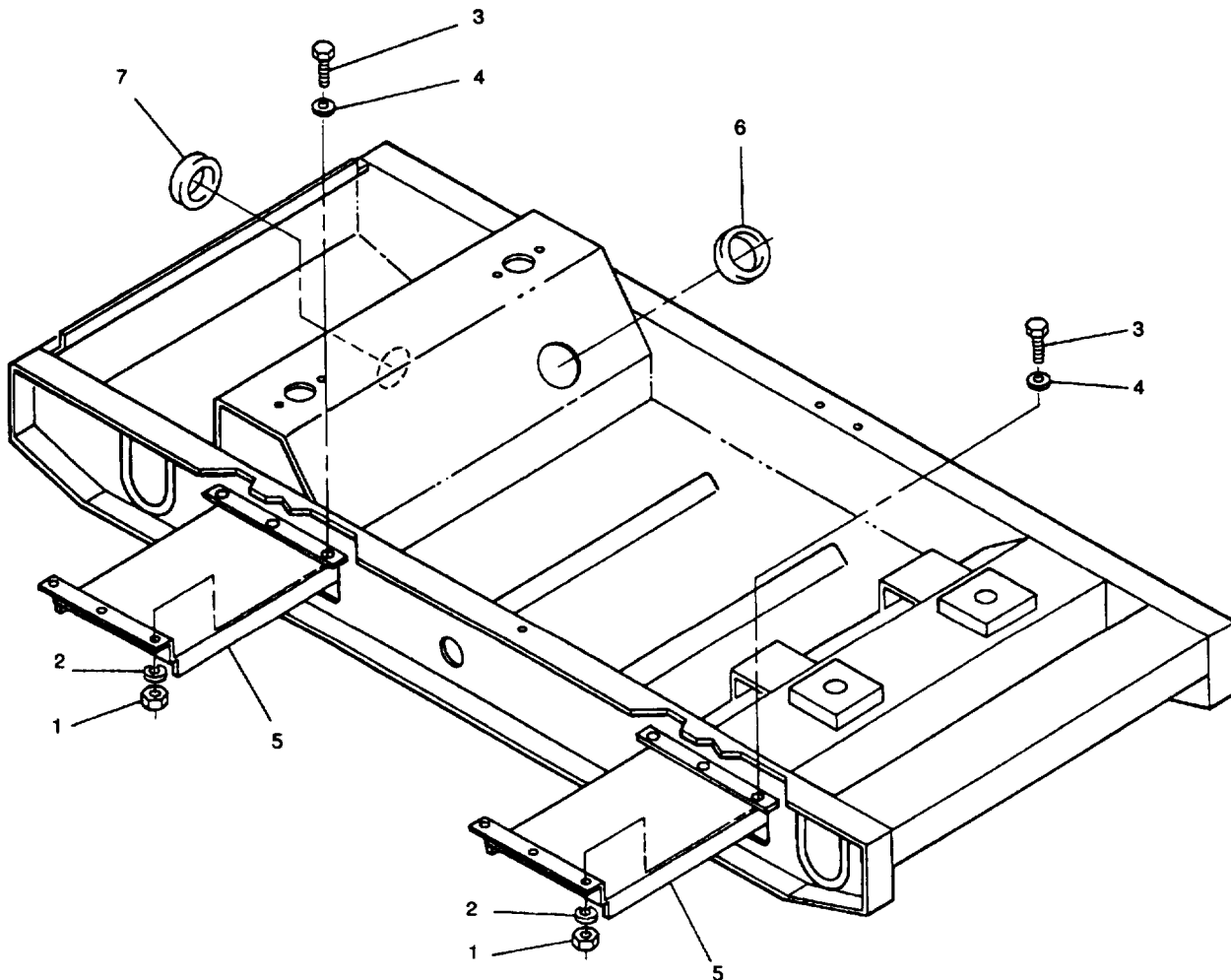

FIGURE 4-16. Skid Base

Section VIII. MAINTENANCE OF LUBRICATION SYSTEM

4-26 Oil DRAIN LINE.

4-26-1 Removal. For removal and installation of oil drain line, refer to paragraph 3-7.

APPENDIX A
REFERENCES

A-1 SCOPE.

This appendix lists all forms, field manuals, technical manuals and miscellaneous publications referenced in this manual.

A-2 FORMS.

Air Force Reporting of Errors Form.....	AFTO Form 22
Equipment inspection and Maintenance Work sheet	DA Form 2404
Marine Corps Reporting of Errors Form	NAVMC Form 10772
Product Quality Deficiency Report	SF 368
Recommended Changes to Publications and Blank Forms	DA Form 2028
Recommended Changes to DA Publications	DA Form 2028-2

A-3 FIELDS MANUALS

First Aid for Soldiers	FM 21-11
NBC Decontamination	FM 3-5
NBC Contamination Avoidance	FM 3-3
NBC Protection	FM 3-4

A-4 TECHNICAL MANUALS.

Cooling Systems: Tactical Vehicle s.....	TM 750-254
Destruction of Materiel	TM 750-244-3
Operator's Unit, Direct Support and General Support Maintenance Manual for Lead-Acid Storage Batteries	TM9-6140-200-14
Operator's Manual: Generator Set, Tactical Quiet, 30kW, 60/400 Hz	TM9-6115-644-10
Painting instructions for Army Materiel	TM43-0139
Repair Parts and Special Tools List: Generator Set, Tactical Quiet, 30kW, 60/400	TM9-6115-644-24P
Unit, Direct Support Maintenance Manual: Engine, Diesel	TM9-2815-255-24

APPENDIX A

REFERENCES - CONTINUED

A-5 MISCELLANEOUS PUBLICATIONS.

Maintenance Management Policy (MMP) AFR-66-1
Corrosion and Corrosion Prevention Metals MIL-HDBK-729
Lubrication Order: Generator Set, Tactical Quiet, 30 kW, 60/400 Hz LO 9-6115-644-12
Marine Corps Maintenance Forms and Records TM4700-15/1
Marking For Shipment and Storage MIL-STD-129
Packaging of Generator Set, Mobile Power and Supplemental Equipment MIL-G-28554
Preparation For Shipment and Storage of Engines MIL-E-10062
Preservation of USAMECOM Mechanical Equipment for Shipment and Storage TB740-97-2
Processing and Inspection of Nonmounted, Nonaircraft Gasoline and
Diesel Engines for Storage and Shipment TO 38-1-5
The Army Maintenance Management System (TAMMS) DA PAM 738-750

APPENDIX B

MAINTENANCE ALLOCATION CHART

Section I. INTRODUCTION

B-1 GENERAL.

- a. This section provides a general explanation of all maintenance and repair functions authorized at various maintenance categories.
- b. The Maintenance Allocation Chart (MAC) in section H designates overall authority and responsibility for the performance of maintenance functions on the T.Q. Generator Sets and its components. The application of the maintenance functions to the generator sets or components will be consistent with the capacities and capabilities of the designated maintenance categories.
- c. Section III lists the tools and test equipment (both special tools and common tool sets) required for each maintenance function as referenced from section II.
- d. Section IV contains supplemental instructions and explanatory notes for particular maintenance functions.

B-2 MAINTENANCE FUNCTIONS. Maintenance functions will be limited to and defined as follows:

- a. Inspect. To determine the service ability of an item by comparing its physical, mechanical, and/or electrical characteristics with established standards through examination (e.g., by sight, sound, or feel).
- b. Test. To verify serviceability by measuring the mechanical, pneumatic, or electrical characteristics of an item and comparing those characteristics with prescribed standards.
- c. Service. Operations required periodically to keep an item in proper operating condition, i.e., to dean (include decontaminate, when required), to preserve, to drain, to paint, or to replenish fuel, lubricants, chemical fluids, or gases.
- d. Adjust. To maintain or regulate, within prescribed limits, by bringing into proper or exact position, or by setting the operating characteristics to specified parameters.
- e. Aline. To adjust specified variable elements of an item to bring about optimum or desired performance.
- f. Calibrate. To determine and cause corrections to be made or to be adjusted on instruments or Test, Measuring, and Diagnostic Equipment (TMDE) used in precision measurement. Consists of comparisons of two instruments, one of which is a certified standard of known accuracy, to detect and adjust any discrepancy in the accuracy of the instrument being compared.
- g. Remove/install. To remove and install the same item when required to perform service or other maintenance functions. Install may be the act of emplacing, seating, or fixing into position a spare, repair part, or module (component or assembly) in a manner to allow the proper functioning of an equipment or system.
- h. Replace. To remove an unserviceable item and install a serviceable counterpart in its place. "Replace" is authorized by the MAC and is shown as the 3rd position code of the SMR code.

- i. Repair. The application of maintenance services, including fault location troubleshooting, removal/installation and disassembly/assembly procedures, and maintenance actions to identify troubles and restore serviceability to an item by correcting specific damage, fault, malfunction, or failure in a part, subassembly, module (component or assembly), end item, or system.
- j. Overhaul. That maintenance effort (service/action) prescribed to restore an item to a completely serviceable/operational condition as required by maintenance standards in appropriate technical publications (i.e., DMWR). Overhaul is normally the highest degree of maintenance performed by the Army. Overhaul does not normally return an item to like new condition.
- k. Rebuild. Consists of those service/actions necessary for the restoration of unserviceable equipment to a like new condition in accordance with original manufacturing standards. Rebuild is the highest degree of material maintenance applied to Army equipment. The rebuild operation includes the act of returning to zero those age measurements (hours/miles, etc.) considered in classifying Army equipment/components.

B-3 EXPLANATION OF COLUMNS IN MAC, SECTION II.

- a. Column 1, Group Number. Column 1 lists functional group code numbers, the purpose of which are to identify maintenance significant components, assemblies, subassemblies, and modules with the next higher assembly. End item group number shall be "00".
- b. Column 2, Component/Assembly. Column 2 contains the names of components, assemblies, subassemblies, and modules for which maintenance is authorized.
- c. Column 3, Maintenance Function. Column 3 lists the function to be performed on the item listed in column 2. (For detailed explanation of these functions, see paragraph B-2).
- d. Column 4, Maintenance Category. Column 4 specifies, by the listing of a work time figure in the appropriate subcolumn(s), the category of maintenance authorized to perform the function listed in column 3. This figure represents the active time required to perform that maintenance function at the indicated category of maintenance. If the number or complexity of the tasks within the listed maintenance function vary at different maintenance categories, appropriate work time figures will be shown for each category. The work time figure represents the average time required to restore an item (assembly, subassembly, component, module, end item, or system) to a serviceable condition under typical field operating conditions. This time includes preparation time (including any necessary disassembly/assembly time), troubleshooting/fault location time, and quality assurance/quality control time in addition to the time required to perform the specific tasks identified for the maintenance functions authorized in the Maintenance Allocation Chart. The symbol designations for the various maintenance categories are as follows:

C	Operator or crew
O	Organization Maintenance
F	Direct Support Maintenance
H	General Support Maintenance
D	Depot Maintenance

- e. Column 5, Tools and Equipment. Column 5 specifies, by code, those common tool sets (not individual tools) and special tools, TMDE, and support equipment required to perform the designated function.
- f. Column 6, Remarks. This column shall, when applicable, contain a letter code, in alphabetical order, which shall be keyed to the remarks contained in Section IV.

B-4 EXPLANATION OF COLUMNS IN TOOL AND TEST EQUIPMENT REQUIREMENTS, SECTION III.

- a. Column 1, Reference Code. The tool and test equipment reference code correlates with a code used in the MAC, Section II, Column 5.

- b. Column 2, Maintenance Category. The lowest category of maintenance authorized to use the tool or test equipment.
- c. Column 3, Nomenclature. Name or identification of the tool or test equipment.
- d. Column 4, National Stock Number. The National Stock Number of the tool or test equipment.
- e. Column 5, Tool Number. The manufacturer's part number of the tool or test equipment.

B-5 EXPLANATION OF COLUMNS IN REMARKS, SECTION IV.

- a. Column 1, Reference Code. The code recorded in column 6, Section II.
- b. Column 2, Remarks. This column lists information pertinent to the maintenance function being performed as indicated in the MAC, Section II.

Section II. MAINTENANCE ALLOCATION CHART
 FOR
 MEP-805A AND MEP-815A

(1) GROUP NUMBER	(2) COMPONENT/ ASSEMBLY	(3) MAINTENANCE FUNCTION	(4) MAINTENANCE CATEGORY					(5) TOOLS AND EQUIP.	(6) REMARKS	
			C	O	F	H	D			
00	GENERATOR SET 30KW (LESS ENGINE)	INSPECT	.2	.5				1,2,3,4		
		TEST		1.0	1.0					
		SERVICE	.3	.3						4
		ADJUST		.3	1.0					1,2,4
01	D.C. ELECTRICAL SYSTEM	REPAIR		2.5	3.5			1,3,3,4		
		INSPECT	.1	.1						
		TEST		.2				1,4		
		REPAIR		.3				1,4		
0101	BATTERY AND SLAVE RECEPTACLE CABLES	INSPECT	.1	.1						
		REPAIR		.3				1,4		
		REM/INST		.2				4		
		REPLACE		.3				1,4		
0102	BATTERIES	INSPECT	.1	.1						
		TEST		.1				1,4		
		SERVICE	.1	.1				4		
		REM/INST		.2				4		
		REPLACE		.2				4		
0103	SLAVE RECEPTACLE	INSPECT	.1	.1						
		REM/INST		.1				4		
		REPLACE		.1				4		
02	HOUSING	INSPECT	.2	.3						
		REPAIR		1.0				4		
		REM/INST		2.0				4		
0201	ACCESS DOORS	INSPECT	.1	.1						
		REPAIR		.5				4		
		REM/INST		.5				4		
		REPLACE		.5				4		
0202	TOP HOUSING SECTION	INSPECT	.1	.2						
		REPAIR		1.0				4		
		REM/INST		1.0				4		
		REPLACE		1.0				4		
0203	FRONT HOUSING SECTION	INSPECT	.1	.2						
		REPAIR		1.0				4		
		REM/INST		.6				4		
		REPLACE		.6				4		

**SECTION II. MAINTENANCE ALLOCATION CHART
 FOR
 MEP-805A AND MEP-815A - Continued**

(1) GROUP NUMBER	(2) COMPONENT/ ASSEMBLY	(3) MAINTENANCE FUNCTION	(4) MAINTENANCE CATEGORY					(5) TOOLS AND EQUIP.	(6) REMARKS
			C	O	F	H	D		
0204	REAR HOUSING SECTION	INSPECT	.1	.2					
		REPAIR		1.0				4	
		REM/INST		1.0				4	
		REPLACE		1.0				4	B
0205	DECALS AND PLATES	INSPECT	.1	.1					
		REM/INST		.3				1,5	
		REPLACE		.3				1,5	B
03	CONTROL BOX ASSEMBLY	INSPECT	.1	.2					
		TEST		1.0	.5			1,2,3,4,6,7	
		REPAIR		1.0	2.0			1,3,4,	
		REM/INST		.2				4	
		REPLACE			.2			4	B
0301	PANEL LIGHTS	INSPECT	.1	.1					
		REM/INST		.3				4	
		REPLACE		.3				4	B
		REPAIR		.2					C
0302	INDICATORS	INSPECT	.1	.1					
		TEST		.3				1,4	
		REM/INST		.2				4	
		REPLACE		.2				4	B
0303	SWITCHES	INSPECT	.1	.1					
		TEST		.2				1,4	
		REM/INST		.2				1,4	
		REPLACE		.2				1,4	B
0304	CONVENIENCE RECEPTACLE	INSPECT	.1	.1					
		TEST		.2				1,4	
		REM/INST		.5				4	
		REPLACE		.5				4	B
0305	GROUND FAULT INTERRUPTER	INSPECT	.1	.1					
		TEST	.1	.1				1,4	
		REM/INST		.5				4	
		REPLACE		.5				4	B
0306	MALFUNCTION INDICATOR PANEL	INSPECT	.1	.1					
		TEST	.1	.1					
		REM/INST		.5				4	
		REPLACE		.5				4	B

SECTION II. MAINTENANCE ALLOCATION CHART
 FOR
 MEP-805A AND MEP-815A - Continued

(1) GROUP NUMBER	(2) COMPONENT/ ASSEMBLY	(3) MAINTENANCE FUNCTION	(4) MAINTENANCE CATEGORY					(5) TOOLS AND EQUIP.	(6) REMARKS
			C	O	F	H	D		
0307	FUSE AND CIRCUIT BREAKER	INSPECT	.1	.1					
		TEST		.2				1,4	
		REM/INST REPLACE		.5				1,4	B
0308	VOLTAGE REGULATOR	INSPECT		.1					
		TEST			.5			1,4	
		REM/INST REPLACE			.5			4	B
0309	RELAYS AND TRANSDUCERS	INSPECT		.1					
		TEST		.3	1.0			1, 2,4,6,7	
		REM/INST REPLACE		.4				4	B
0310	GOVERNOR CONTROL UNIT	INSPECT	.1	.1					
		TEST			1.0			2,4	
		ADJUST REM/INST REPLACE		.2	1.0			2,4	B
0311	CONTROL BOX HARNESS	INSPECT	.1	.2	.2				
		TEST		1.0	1.0			1,3,4	
		REPAIR		.5	1.0			1,3,4	
		REM/INST REPLACE			1.5			1,4	B
0312	LOAD MEASURING UNIT	INSPECT	.1	.1					
		TEST			.5			3,4	
		REM/INST REPLACE		.5				4	B
0313	RESISTOR-DIODE ASSEMBLY	INSPECT	.1	.1					
		TEST		.5				1,4	
		REPAIR		1.0				1,4	
		REM/INST REPLACE		1.0				1,4	B
0314	CONTROL BOX PANELS	INSPECT	.1	.1					
		REPAIR		.2				4	
		REM/INST REPLACE		3.0				4	B
0315	DECALS AND PLATES	INSPECT	.1	.1					
		REM/INST		.3				1,5	
		REPLACE		.3				1,5	B

**SECTION II. MAINTENANCE ALLOCATION CHART
 FOR
 MEP-805A AND MEP-815A - Continued**

(1) GROUP NUMBER	(2) COMPONENT/ ASSEMBLY	(3) MAINTENANCE FUNCTION	(4) MAINTENANCE CATEGORY					(5) TOOLS AND EQUIP.	(6) REMARKS
			C	O	F	H	D		
04	AIR INTAKE/ EXHAUST SYSTEM	INSPECT REPAIR	.2	.2 1.5				4	
0401	MUFFLER AND PIPES	INSPECT REM/INST REPLACE	.1	.5 .7 .7				4 4 4	B
0402	AIR CLEANER ASSEMBLY	INSPECT SERVICE REPAIR REM/INST REPLACE	.1 .2	.2 .2 .5 .5 .5				4 4 4 4 4	B
05	COOLANT SYSTEM	INSPECT TEST SERVICE REPAIR	.1 .1	.2 .2 .5 1.0				1,8 4 1,3,4	B
0501	COOLANT HOSES	INSPECT REM/INST REPLACE	.1	.1 .5 .5				4 4	B
0502	RADIATOR	INSPECT REPAIR REM/INST REPLACE	.1	.2 1.0 1.0 1.0		2.0		1,3,4 4 4	B
0503	COOLING FAN	INSPECT REM/INST REPLACE	.1	.1 .8 .8				4 4 4	B
0504	FAN BELT	INSPECT TEST ADJUST REM/INST REPLACE	.1	.1 .1 .5 .5 .5				4 4 4 4 4	B
0505	COOLANT RECOVERY SYSTEM	INSPECT REM/INST REPLACE	.1	.1 .5 .5				4 4 4	B
06	FUEL SYSTEM	INSPECT REPAIR	.1	.2 1.0		1.5		4	
0601	LOW PRESSURE FUEL LINES	INSPECT REM/INST REPLACE	.1	.2 .5 .5				4 4 4	B

SECTION II. MAINTENANCE ALLOCATION CHART
 FOR
 MEP-805A AND MEP-815A - Continued

(1) GROUP NUMBER	(2) COMPONENT/ ASSEMBLY	(3) MAINTENANCE FUNCTION	(4) MAINTENANCE CATEGORY					(5) TOOLS AND EQUIP.	(6) REMARKS
			C	O	F	H	D		
0602	AUX. FUEL PUMP	INSPECT TEST REPAIR REM/INST REPLACE		.1 .5 .5 .5 .5				4 4 4 1,4	
0603	FUEL TANK	INSPECT SERVICE REM/INST REPLACE	.3	.2				4 4	B
0604	FUEL TANK FLOATS AND SWITCHES	INSPECT TEST REM/INST REPLACE		.2 .3 .5 .5				1,4 4 4	B
0605	ETHER START SYSTEM	INSPECT SERVICE REPAIR REM/INST REPLACE	.1	.2 .2 .5 .5 .5				4 4 4 4	B
07	OUTPUT BOX ASSEMBLY	INSPECT TEST REPAIR REM/INST REPLACE		.2 1.0 2.0	2.0 3.0 2.0 2.0			1,3,4 1,3,4 4 4	B
0701	VOLTAGE RECONNECTION BOARD	INSPECT REM/INST REPLACE		.2		.4 .4		4 4	B
0702	OUTPUT BOX HARNESS & CABLES	INSPECT TEST REPAIR REM/INST REPLACE	.1	.2 .6 .5		1.0 2.0 2.0		1,2,4 1,3,4 4 4	B
0703	TRANSFORMERS	INSPECT TEST REM/INST REPLACE	.1	.2		1.0 1.3 1.3		2,4 4 4	B
0704	A.C. CIRCUIT INTERRUPTER	INSPECT TEST REM/INST REPLACE		.2 .5 .5 .5				1,4 4 4	B

SECTION II. MAINTENANCE ALLOCATION CHART
 FOR
 MEP-805A AND MEP-815A - Continued

(1) GROUP NUMBER	(2) COMPONENT/ ASSEMBLY	(3) MAINTENANCE FUNCTION	(4) MAINTENANCE CATEGORY					(5) TOOLS AND EQUIP.	(6) REMARKS
			C	O	F	H	D		
0705	START RELAY	INSPECT		.2					
		TEST		.5				1,4	
		REM/INST		.5				4	
		REPLACE		.5				4	B
0706	OUTPUT BOX PANELS	INSPECT	.1	.1					
		REPAIR		.2	1.0			4	
		REM/INST			2.0			4	
		REPLACE			2.0			4	B
0707	AUXILARY FUEL FILTER	INSPECT	.1						
		REM/INST		.2				4	
		REPLACE		.2				4	
08	OUTPUT LOAD TERMINAL BOARD ASSEMBLY	INSPECT	.1	.1					
		TEST		.5				1	
		REPAIR		1.0				4	
		REM/INST		1.5				4	
		REPLACE		1.5				4	B
0801	LOAD TERMINALS	INSPECT		.1					
		REPAIR		.5				4	
		REM/INST		.5				4	
		REPLACE		.5				4	B
0802	VARISTORS	INSPECT		1.0					
		TEST		1.1				1,4	
		REM/INST		1.0				4	
		REPLACE		1.0				4	B
0803	LOAD TERMINAL BOARD	INSPECT	.1	.1					
		REM/INST		1.5				4	
		REPLACE		1.5				4	B
09	ENGINE ACCESSORIES	INSPECT	.1	.1					
		TEST		.5				1,4	
		REPAIR		.5				4	
0901	SENDERS AND SWITCHES	INSPECT	.1	.1					
		TEST		.5				1,4	
		REPAIR		.5				4	
		REM/INST		.5				4	
		REPLACE		.5				4	B

SECTION II. MAINTENANCE ALLOCATION CHART
 FOR
 MEP-805A AND MEP-815A - Continued

(1) GROUP NUMBER	(2) COMPONENT/ ASSEMBLY	(3) MAINTENANCE FUNCTION	(4) MAINTENANCE CATEGORY					(5) TOOLS AND EQUIP.	(6) REMARKS
			C	O	F	H	D		
0902	GOVERNOR ACTUATOR	INSPECT	.1	.1				4	
		TEST			.3			4	
		ADJUST			.3			4	
		REPAIR		.5	.5			1,4	
0903	DEAD CRANK SWITCH	REM/INST			.5			4	B
		REPLACE			.5			4	
		INSPECT	.1	.1				1,4	
		TEST		.5				4	
0904	DECALS AND PLATES	REM/INST		.1				1,5	B
		REPLACE	.1	.1				1,5	
		INSPECT		.3				4	
10	LUBRICATION SYSTEM	REPLACE		.3				4	A
		INSPECT	.1	.2				4	
1001	OIL DRAIN LINE	SERVICE	.2	.2				4	A A
		REPAIR		.5				4	
		INSPECT	.1	.2	.5			4	
		REPAIR		.5	.5			4	
11	GENERATOR ASSEMBLY	REPLACE		.5	.5			4	B
		INSPECT		.1	.1			1,2,3,4	
		TEST		1.0	1.0			4	
		REPAIR			4.0			1,3,4	
12	ENGINE ASSEMBLY	REM/INST			4.0			1,3,4	A A A A
		REPLACE			4.0			1,3,4	
		INSPECT	.2					4	
		SERVICE						4	
13	SKID BASE	ADJUST						4	B
		REPAIR						4	
		REPAIR	.1	.1	1.0			4	
		REPLACE			3.0			4	

**Section III. TOOL AND TEST EQUIPMENT REQUIREMENTS
 FOR
 MEP-805A AND MEP-815A**

TOOL OR TEST EQUIPMENT REF CODE	MAINTENANCE CATEGORY	NOMENCLATURE	NATIONAL/ NATO STOCK NUMBER	TOOL NUMBER
1	O,F	SHOP EQUIPMENT, AUTOMOTIVE MAINT AND REPAIR	4910-00-754-0654	SC4910-95-CL-A74
2	F	SHOP EQUIPMENT, ELECTRICAL REPAIR	4910-01-096-4475	SC4940-95-CL-B05
3	F	SHOP EQUIPMENT, AUTOMOTIVE MAINT AND REPAIR, FIELD	4910-00-348-7696	SC4910-95-CL-A02
4	O,F	TOOL KIT, GENERAL MECHANIC	5180-00-177-7033	SC5180-90-CL-N26
5	O	POP RIVET GUN	5120-00-508-1588	GGG-R-00395
6	O	POTENTIOMETER, 5,000 OHMS	. .	GGG-R-00395
7	O	POTENTIOMETER, 10,000 OHMS	. .	
8	O	TORQUE ADAPTER	5120-01-112-4498	
9	F	5 OHM, 25 WATT RESISTOR		
10	F	ROTOR LIFTING SLING/DEVICE		

**Section IV. REMARKS
 FOR
 MEP-805A AND MEP-815A**

Reference Code	Remarks
A	Refer to TM 9-2815-255-24.
B	Replace function identical to removal/install fund-on.
C	Repair is limited to replacement of light bulbs.

APPENDIX C

EXPENDABLE/DURABLE SUPPLIES AND MATERIALS LIST

Section I. INTRODUCTION

C-1 SCOPE.

This appendix lists expendable supplies and materials you will need to operate and maintain the generator set: These items are authorized to you by CTA50-970, Expendable Items (Except Medical, Class V, Repair Parts, and Heraldic Items).

C-2 EXPLANATION OF COLUMNS.

- a. Column (1) - Item Number. This number is assigned to the entry in the listing and is referenced in the narrative instructions to identify the material (e.g., "Use cleaning compound, Item 5, Appendix (C)").
- b. Column (2) - Level. This column identifies the lowest level of maintenance that requires the listed item.
- c. Column (3) - National Stock Number. This is the National Stock Number assigned to the item; use it to request or requisition the item.
- d. Column (4) - Description. indicates the Federal item name and, if required, a description to identify the item. The last line for each item indicates the Commercial and Government Entity (CAGE) code in parentheses followed by the part number.
- e. Column (5) - Unit of Measure (U/M). Indicates the measure used in performing the actual maintenance function. This measure is expressed by a two-character alphabetical abbreviation (e.g., ea, in, pr). If the unit of measure differs from the unit of issue, requisition the lowest unit of issue that will satisfy your requirements.

Section II. TABULAR LIST

(1) Item Number	(2) Level	(3) stock Number	(4) Description	(5) U/M
1	O,F	8040-00-390-7959	Adhesive, Seal, EC847	QT
2	O,F	6850-00-181-7929	Antifreeze, MIL-A-46153, 1 Gal. Can	GL
3	O,F	6850-00-181-7933	Antifreeze, MIL-A-46153,5 Gal. Can	GL
4	O,F	6850-00-181-7940	Antifreeze, MIL-A-46153,55 Gal. Can	GL
5	O,F	6850-00-174-1806	Antifreeze, MIL-A-11755,1 Gal. Can	GL
6	O,F	8030-01-234-2792	Antiseize, Compound, CP-8, 1/2 Lb. Can	OZ
7	O	2910-00-646-9727	Cartridge, Engine, Ether, MS39254	EA
8	O,F	7920-01-338-3329	Cloth, Cleaning,TX-1250	EA
9	F	8030-00-056-8673	Compound, Thermo, Pentrox A	OZ
10	O,F	9150-00-663-1770	Grease, General Purpose, 630AA, 6 Lb. Can	LB
11	O, F	6850-01-160-3868	Inhibitor, Corrosion, MIL-A-53009	QT
12	O,F	9150-00-152-4117	Lubricating Oil, Engine, MIL-L-2104, 15/40w	QT
13	O,F	9150-00-189-6727	Lubrication Oil, Engine, BRAYC0421 C, 10W	QT
14	O,F	9150-00-186-6681	Lubricating Oil, Engine, ALIEDC030, 30W	QT
15	O,F	9150-00-402-2372	Lubricating Oil, Engine, MIL-L-46167, OEA	QT
16	O,F	5330-00-543-3600	Paper, Abrasive, ALOXGRIT 80	SH
17	O,F	-- -- --	Seal, Edge, PES-821 -B	QT
18	O, F	8040-00-843-0802	Sealant, RTV108	OZ
19	O,F	3439-00-974-1873	Solder, Tin Alloy, SN60WRAP2, 1 Lb. Spool	OZ
20	O,F	6850-00-264-9038	Solvent, Dry Cleaning, P-D-680, 5 Gal. Can	GL
21	O,F	8030-00-849-0071	Sealing Compound, FORM GASKET 2	TU

APPENDIX D FABRICATION/ASSEMBLY OF PARTS

D-1 INTRODUCTION.

This appendix includes complete instructions for fabricating or assembling parts as required on this generator set.

NOTE

All dimensions are expressed in inches, refer to TABLE D-1 for inches to metric conversions.

D-2 ILLUSTRATIONS.

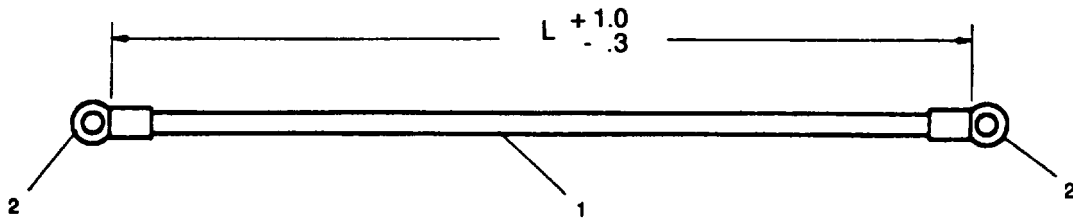

NOTES:

1. Dimensions shown are in inches.
2. Refer to TM 9-6115-644-24P for materials required and length (L) of wire.

PROCEDURES:

1. Cut wire (1) to length indicated.
2. Strip 0.75 inch of insulation from each end of wire (1).
3. Crimp terminal (2) on each end of wire (1).

FIGURE D-1. Cable Assembly, AC Power (P/Ns 88-22126-1 through 88-22126-7)

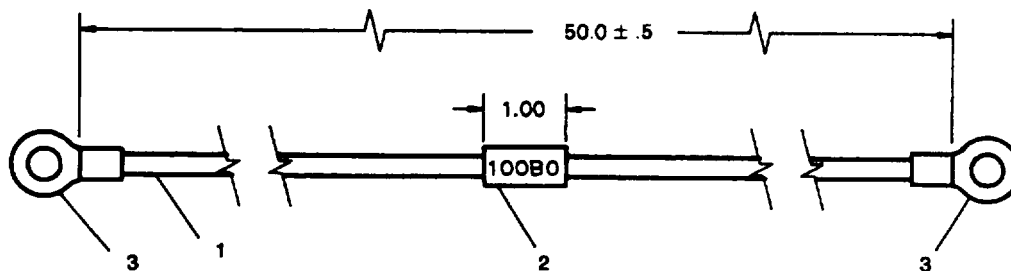

NOTES:

1. Dimensions shown are in inches.
2. Refer to TM 9-6115-644-24P for materials required.

PROCEDURES:

1. Cut wire (1) to length indicated.
2. Strip 0.75 inch of insulation from each end of wire (1).
3. Position insulation sleeving (2) on center of wire, mark with wire number "100B0" end shrink to fit.
4. Crimp terminal (3) on each end of wire (1).

FIGURE D-2. Cable Assembly, Battery (P/N: 88-22178)

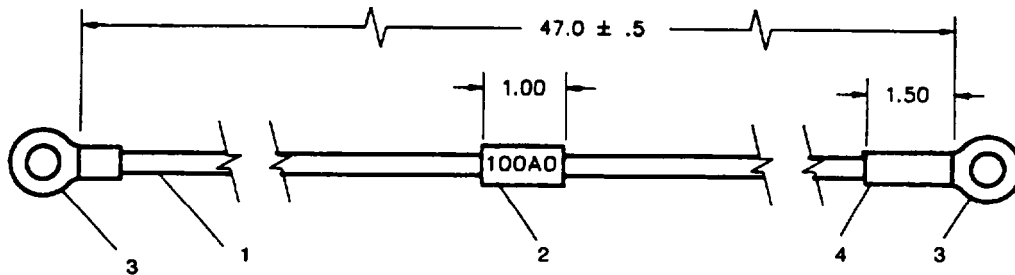

NOTES:

1. Dimensions shown are in inches.
2. Refer to TM9-6115-644-24P for materials required.

PROCEDURES:

1. Cut wire (1) to length indicated.
2. Strip 0.75 inch of insulation from each end of wire (1).
3. Position insulation sleeving (2) on center of wire, mark with wire number "100A0" and shrink to fit.
4. Mark insulation sleeving (4) with "NEGATIVE" and slide over one end of wire (1).
5. Crimp terminal (3) on each end of wire (1).
6. Position insulation sleeving (4) as shown and shrink to fit.

FIGURE D-3. Cable Assembly, Battery (P/N: 88-22127)

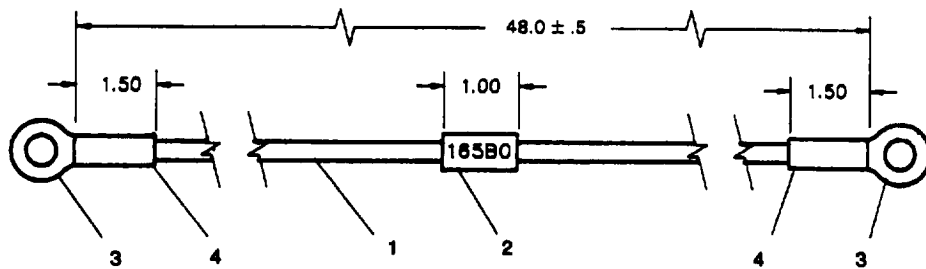

NOTES:

1. Dimensions shown are in inches.
2. Refer to TM 9-6115-644-24P for materials required.

PROCEDURES:

1. Cut wire (1) to length indicated.
2. Strip 0.75 inch of insulation sleeving from each end of wire (1).
3. Mark insulation sleeving (2) with wire number "165B0", position on center of wire and shrink to fit.
4. Mark insulation sleeving (4) with "POSITIVE" and slide over each end of wire (1).
5. Crimp terminal (3) on each end of wire (1).
6. Position insulation sleeving (4) as shown and shrink to fit.

FIGURE D-4. Cable Assembly, Battery (P/N: 88-22181)

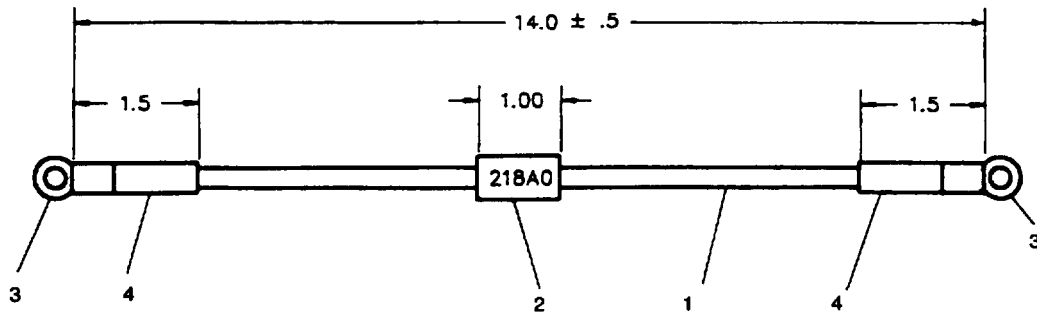

NOTES:

1. Dimensions shown are in inches.
2. Refer to TM 9-6115-644-24P for materials required.

PROCEDURES:

1. Cut wire (1) to length indicated.
2. Strip 0.75 inch of insulation from each end of wire (1).
3. Mark insulation sleeving (2) with wire number "218A0", position on center of wire and shrink to fit.
4. Mark one insulation sleeving (4) with "NEGATIVE", the other with "POSITIVE" and slide over each end of wire (1).
5. Crimp terminal (3) on each end of wire (1).
6. Position insulation sleeving (4) as shown and shrink to fit.

FIGURE D-5. Cable Assembly, Battery (P/N: 88-22179)

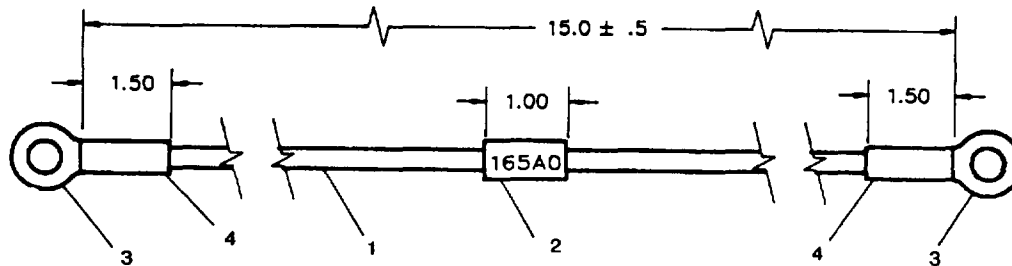

NOTES:

1. Dimensions shown are in inches.
2. Refer to TM 9-6115-644-24P for materials required.

PROCEDURES:

1. Cut wire (1) to length indicated.
2. Strip 0.75 inch of insulation sleeving from each end of wire (1).
3. Mark insulation sleeving (2) with wire number '165A0', position on center of wire and shrink to fit.
4. Mark insulation sleeving (4) with "POSITIVE" and slide over each end of wire (1).
5. Crimp terminal (3) on each end of wire (1).
6. Position insulation sleeving (4) as shown and shrink to fit.

FIGURE D-6. Cable Assembly, Battery (P/N: 88-22207)

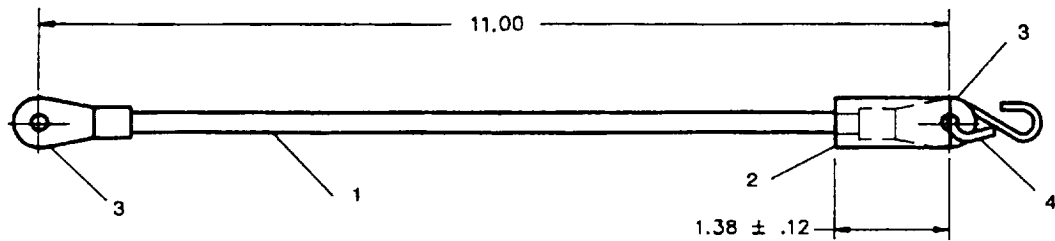

NOTES:

1. Dimensions shown are in inches.
2. Refer to TM 9-6115-644-24P for materials required.

PROCEDURES:

1. Cut rope (1) to length indicated.
2. Slide insulation sleeving (2) over one end of rope (1).
3. Crimp terminal (3) on each end of rope (1).
4. Install hook (4) in one terminal (3) and close hook end securing it to terminal.
5. Position insulation sleeving (2) as shown and shrink to fit.

FIGURE D-7. Holder, Control Panel (P/N: 88-22120)

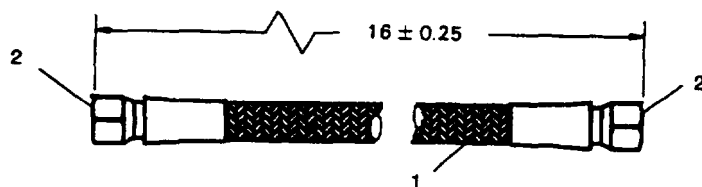

NOTES:

1. Dimensions shown are in inches.
2. Refer to TM 9-6115-644-24P for materials required.

PROCEDURES:

1. Cut hose (1) to obtain dimension shown with adapters (2) installed.
2. Crimp adapter (2) on each end of hose (1).

FIGURE D-8. Hose Assembly (P/N: 88-20191-6)

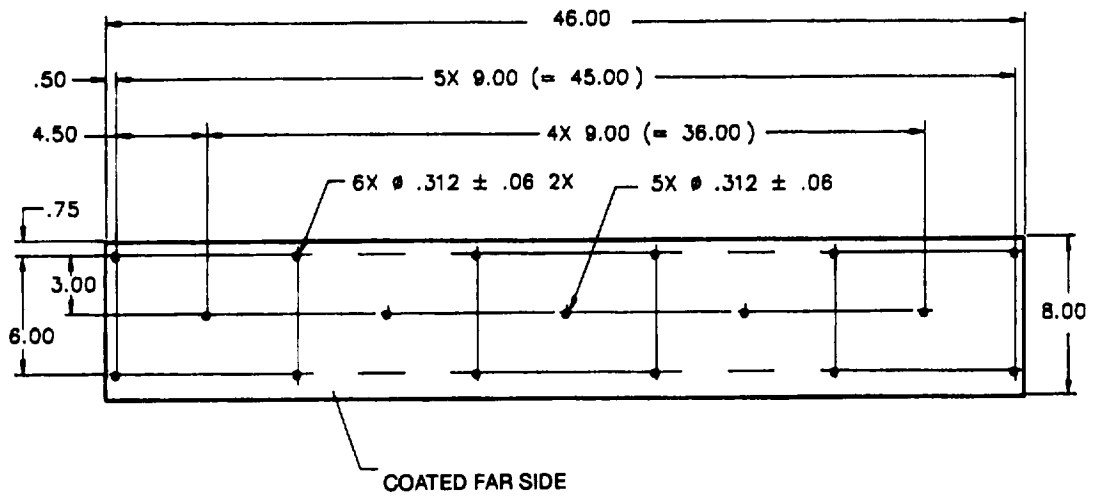

MATERIALS	
Description	Part Number
Foam, Sound Absorbing	FF40JM02

NOTES:

1. Dimensions shown are in inches.
2. Tolerances are 0.1 inch unless otherwise Stated

PROCEDURES:

1. Cut foam to dimensions shown.
2. Drill holes as shown.

FIGURE D-9. Insulation, Panel, Top (P/N: 88-22582)

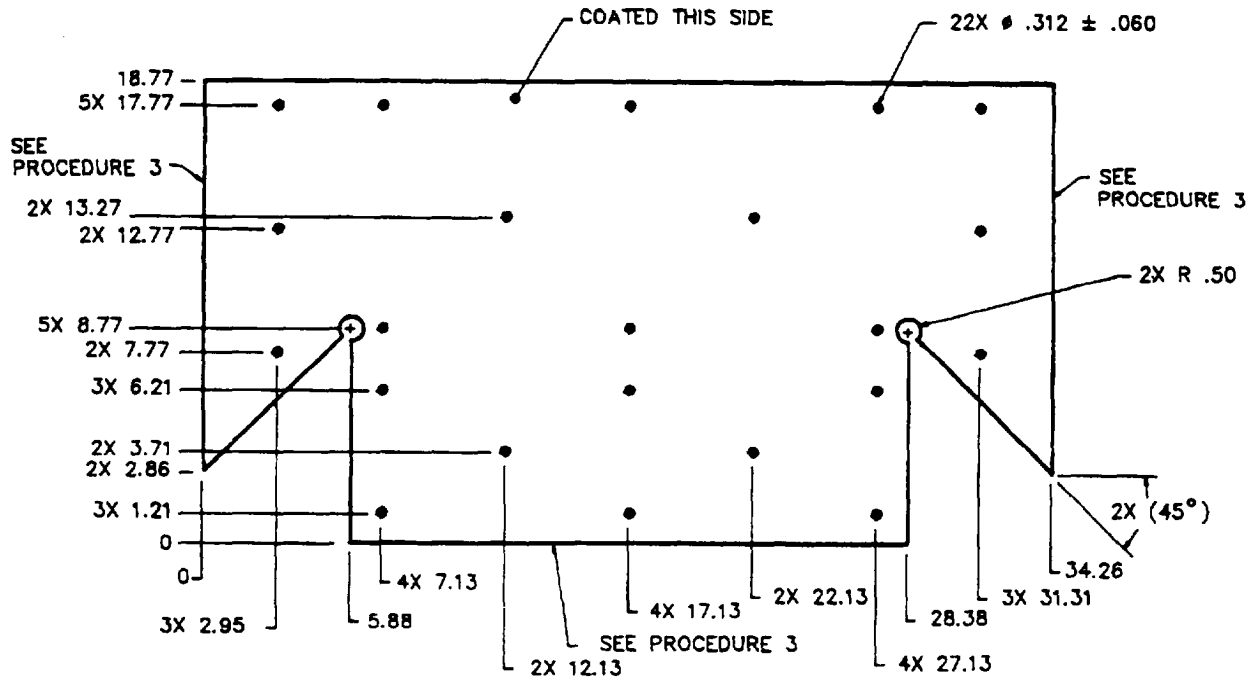

MATERIALS	
Description	Part Number
Foam, Sound Absorbing	FF40JM02

NOTES:

1. Dimensions shown are in inches.
2. Tolerances are 0.1 inch unless otherwise stated.

PROCEDURES:

1. Cut foam to dimensions shown.
2. Drill holes as shown.
3. Coat this edge using sealant (Item 17, Appendix C).

FIGURE D-10. Insulation, Baffle (P/N: 88-22592)

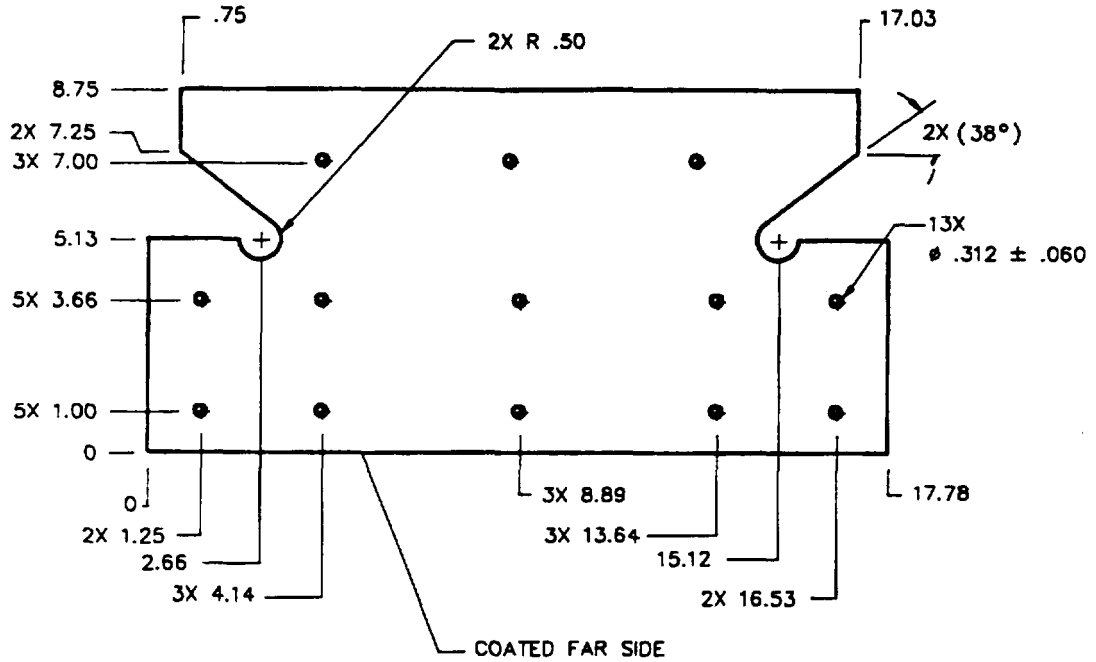

MATERIALS	
Description	Part Number
Foam, Sound Absorbing	FF40JM02

NOTES:

1. Dimensions shown are in inches.
2. Tolerances are 0.1 inch unless otherwise stated.

PROCEDURES

1. Cut foam to dimensions shown.
2. Drill holes as shown.

FIGURE D-11. Insulation, Baffle (P/N: 88-22593)

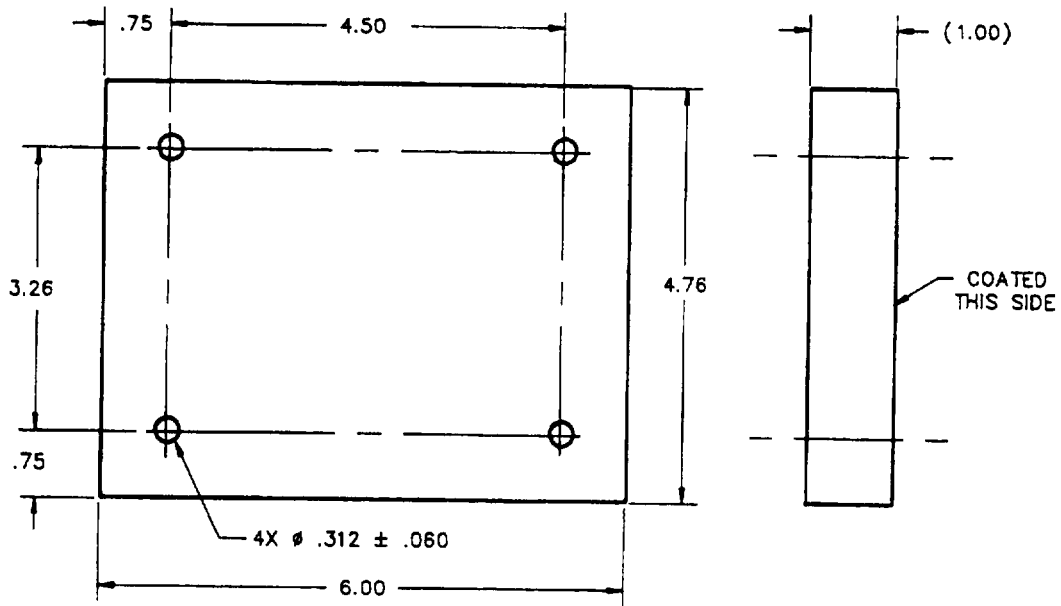

MATERIALS	
Description	Part Number
Foam, Sound Absorbing	FF40JM02

NOTES:

1. Dimensions shown are in inches.
2. Tolerances are 0.1 inch unless otherwise stated.

PROCEDURES:

1. Cut foam to dimensions shown.
2. Drill holes as shown.

FIGURE D-12. Insulation, Top, Center (P/N: 88-22584)

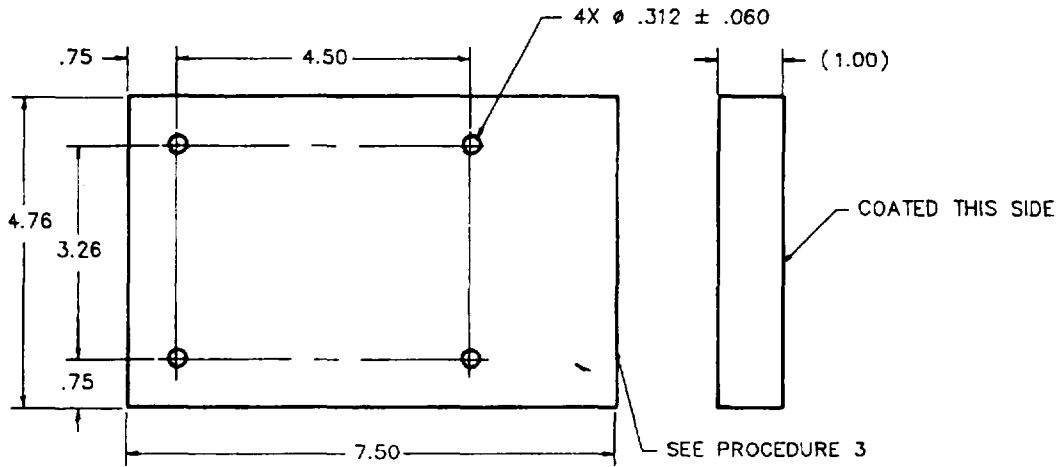

MATERIALS

Description
 Foam, Sound Absorbing

Part Number
 FF40JM02

NOTES:

1. Dimensions shown are in inches.
2. Tolerances are 0.1 inch unless otherwise stated.

PROCEDURES:

1. Cut foam to dimensions shown.
2. Drill holes as shown.
3. Coat this edge using sealant (Item 17, Appendix C).

FIGURE D-13. Insulation, Top, Rear (P/N: 88-22585)

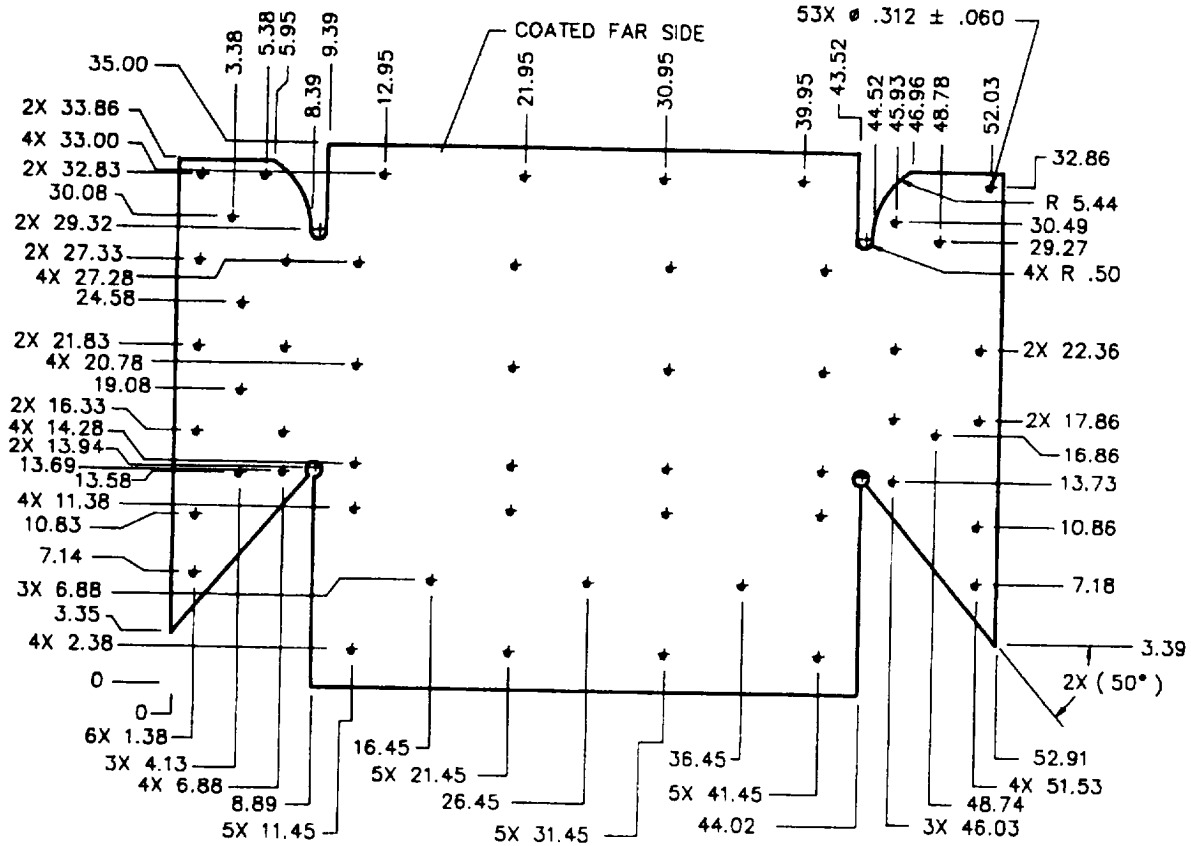

MATERIALS	
Description	Part Number
Foam, Sound Absorbing	FF40JM02

NOTES:

1. Dimensions shown are in inches.
2. Tolerances are 0.1 inch unless otherwise stated.

PROCEDURES:

1. Cut foam to dimensions shown.
2. Drill holes as shown.

FIGURE D-14. Insulation, Front Housing (P/N: 88-22591)

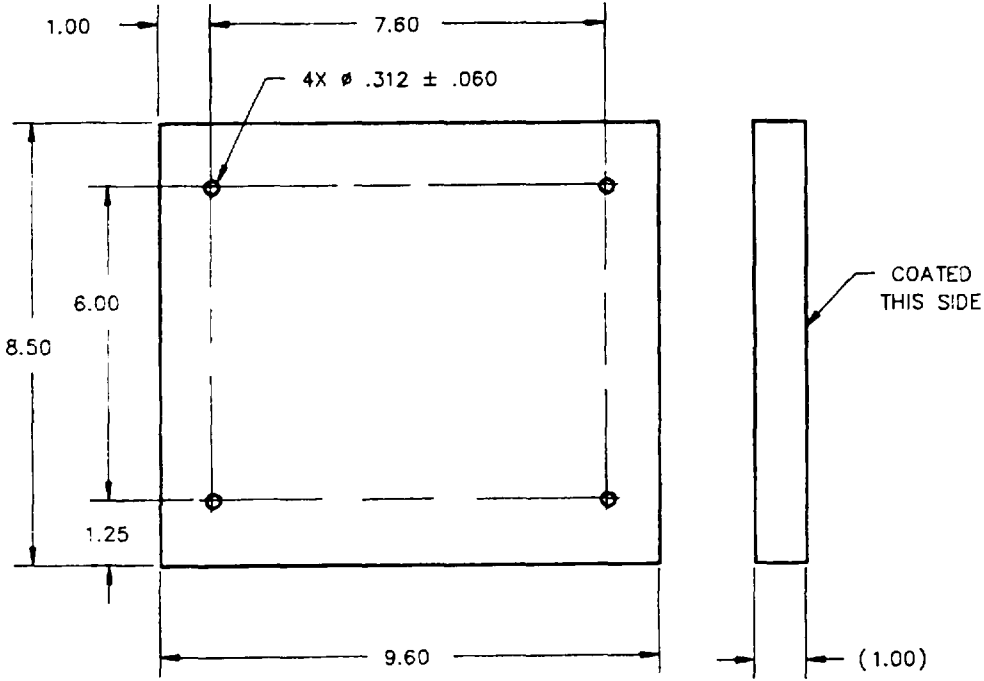

MATERIALS

Description	Part Number
Foam, Sound Absorbing	FF40JM02

NOTES:

1. Dimensions shown are in inches.
2. Tolerances are 0.1 inch unless otherwise stated.

PROCEDURES:

1. Cut foam to dimensions shown.
2. Drill holes as shown

FIGURE D15. Insulation, Top, Front (P/N: 88-22586)

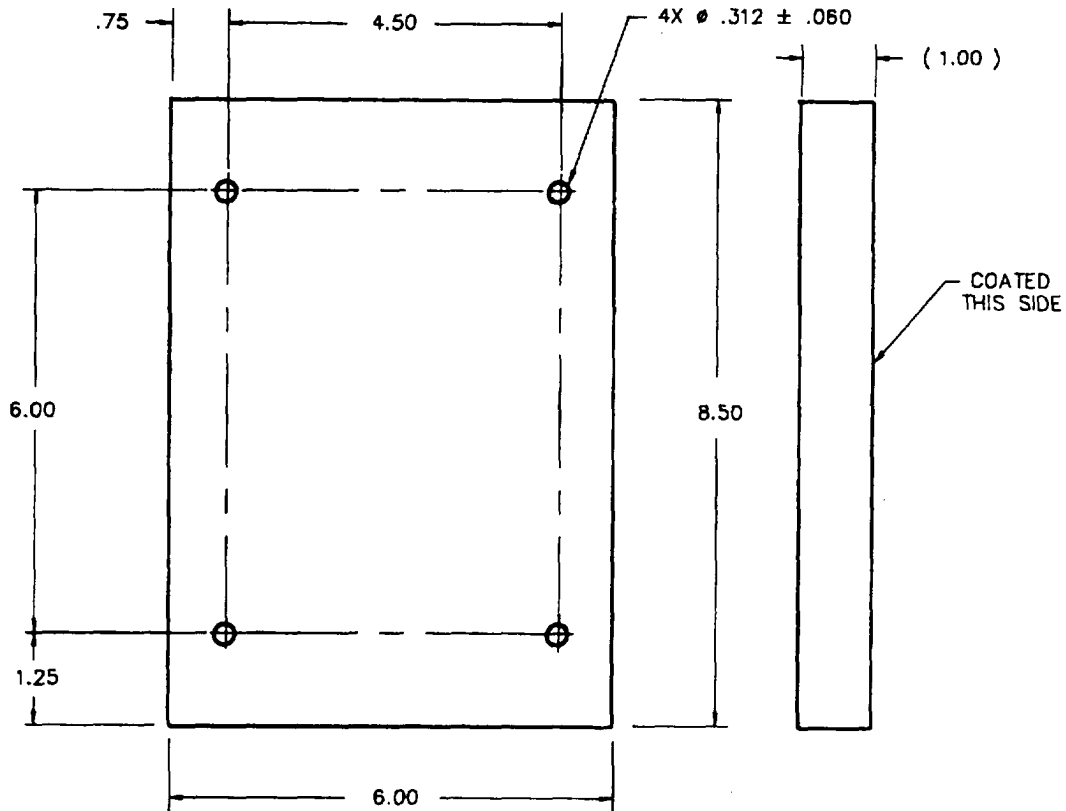

MATERIALS	
Description	Part Number
Foam, Sound Absorbing	FF40JM02

NOTES:

1. Dimensions shown are in inches.
2. Tolerances are 0.1 inch unless otherwise stated.

PROCEDURES:

1. Cut foam to dimensions shown.
2. Drill holes as shown.

FIGURE D-16. Insulation, Top, Center (P/N: 88-22587)

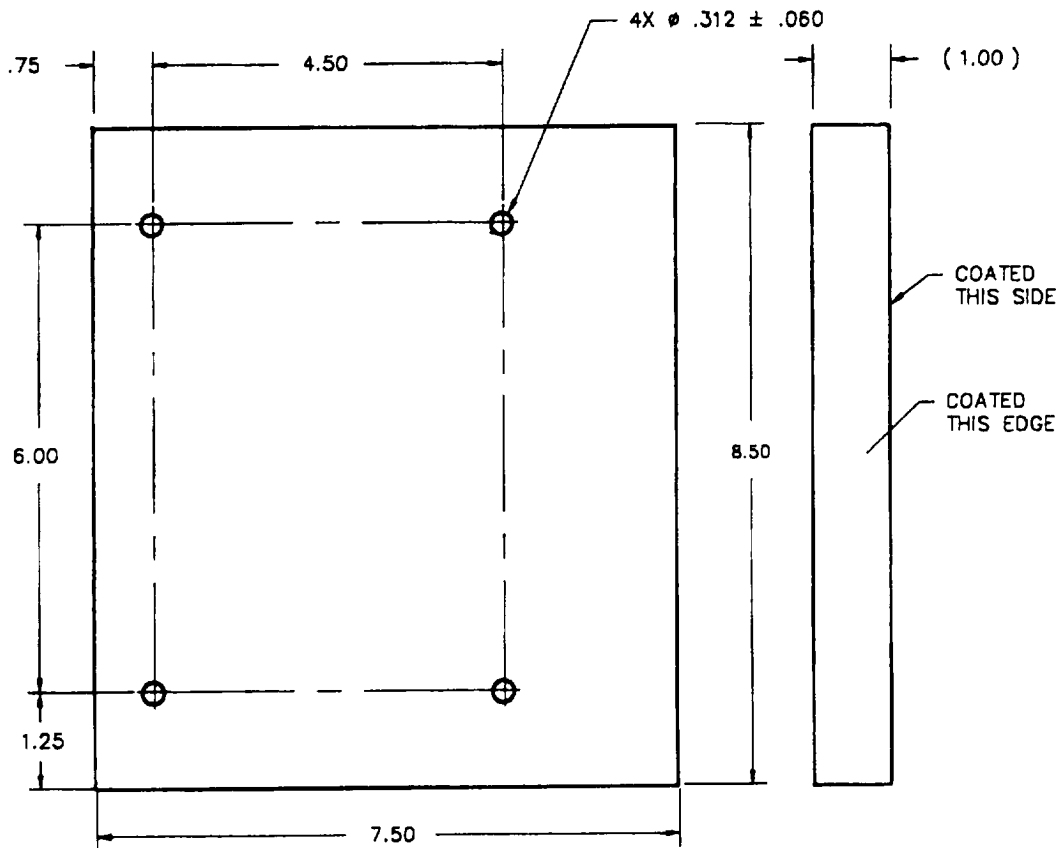

MATERIALS	
Description	Part Number
Foam, Sound Absorbing	FF40JM02

NOTES:

1. Dimensions shown are in inches.
2. Tolerances are 0.1 inch unless otherwise stated.

PROCEDURES:

1. Cut foam to dimensions shown.
2. Drill holes as shown.

FIGURE D-17. Insulation, Top, Center (P/N: 88-22588)

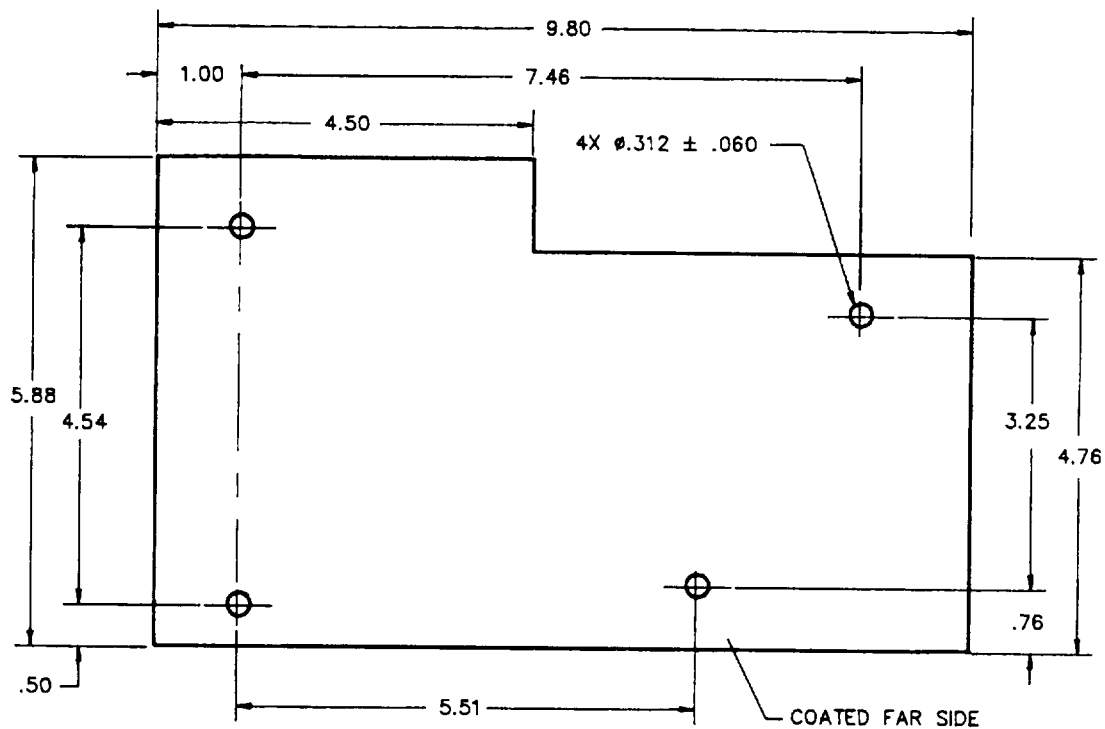

MATERIALS	
Description	Part Number
Foam, Sound Absorbing	FF40JM02

NOTES:

1. Dimensions shown are in inches.
2. Tolerances are 0.1 inch unless otherwise stated.

PROCEDURES:

1. Cut foam to dimensions shown.
2. Drill holes as shown.

FIGURE D-18. Insulation, Top, Front (P/N: 88-22583)

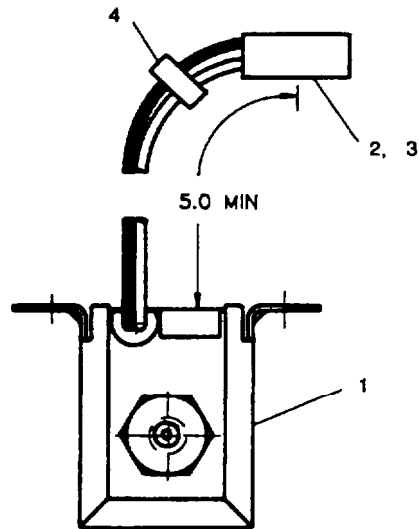

NOTES:

1. Dimensions shown are in inches.
2. Refer to TM-9-6115-644-24P for materials required.

PROCEDURES:

1. Remove and discard terminals supplied with fuel pump (1).
2. Strip 0.125 inch of insulation from end of each pump (1) lead.
3. Crimp pin (2) on end of each lead.
4. Insert pins (2) into housing (3) with red wire in position 1 and black wire in position 2.
5. Mark strap (4) with "P11" and install in position shown.

FIGURE D-19. Pump Assembly, Fuel (P/N: 88-22546)

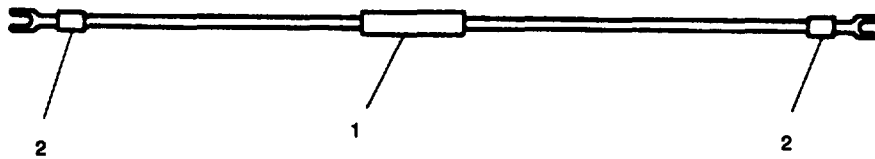

NOTES:

1. Refer to TM 9-6115-644-24P for materials required.
2. Resistors (1) are different depending on part number being assembled.

PROCEDURES:

1. Crimp terminal (2) on end of each resistor (1) lead.

FIGURE D-20. Resistor Assembly (P/Ns: 122-3066-1 and 29879)

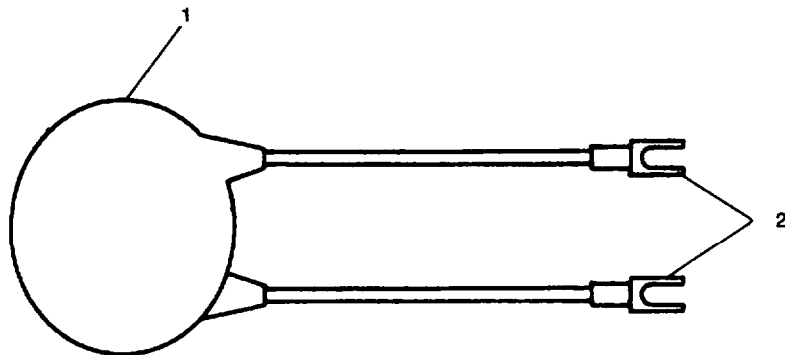

NOTES:

1. Refer to TM 9-6115-644-24P for materials required.

PROCEDURES:

1. Crimp and solder terminals (2) on end of each resistor (1) lead.

FIGURE D-21. Resistor Assembly, Volt (P/N: 88-22631)

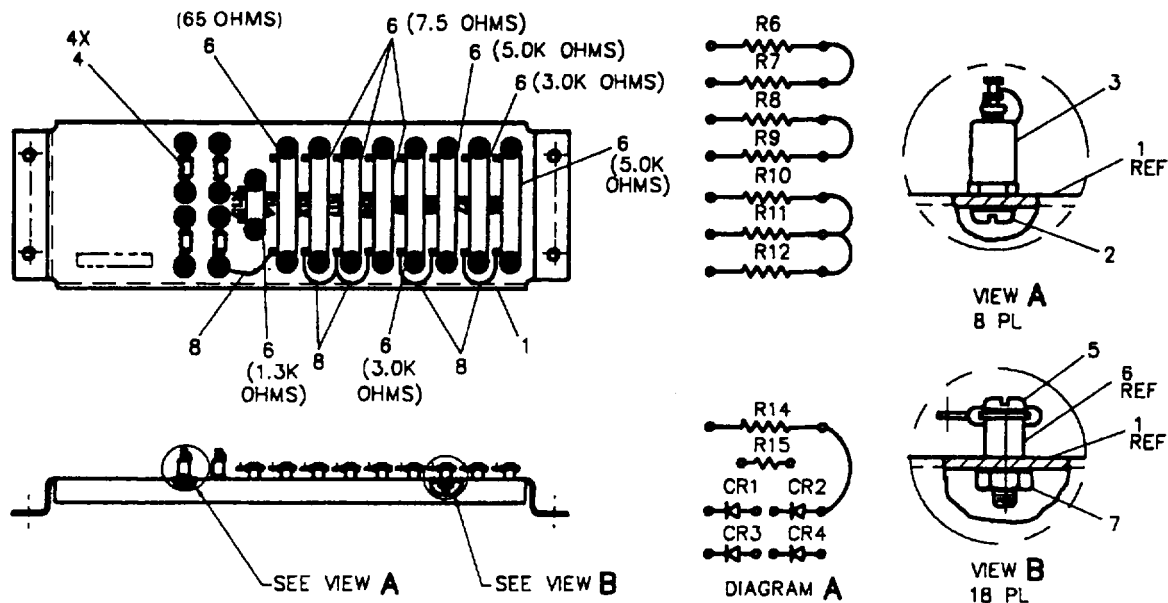

NOTES:

1. Refer to TM 9-6115-644-24P for materials required and positioning of resistors by ohm rating.

PROCEDURES:

1. Install screws (2) and insulated terminals (3) on bracket (1) as shown.
2. solder diodes (4) to insulated terminals (3) as shown.
3. Install screws (5) resistors (6) and nuts (7) on bracket (1) as shown.
4. Position wires (8) and solder connections as shown.

FIGURE D-22. Resistor-Diode Assembly (P/N: 88-22632)

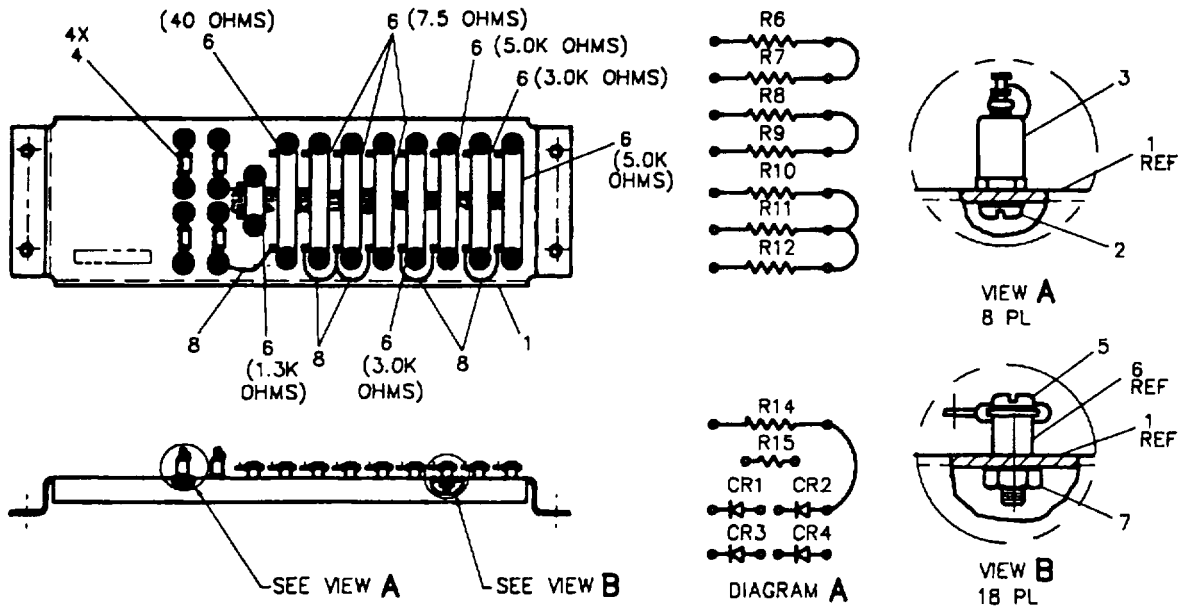

NOTES:

1. Refer to TM 9-6115-644-24P for materials required and positioning of resistors by ohm rating.

PROCEDURES:

1. Install screws (2) and insulated terminals (3) on bracket (1) as shown.
2. Solder diodes (4) to insulated terminals (3) as shown.
3. Install screws (5) resistors (6) and nuts (7) on bracket (1) as shown.
4. Position wires (8) and solder connections as shown.

FIGURE D-23. Resistor-Diode Assembly (P/N: 88-22106)

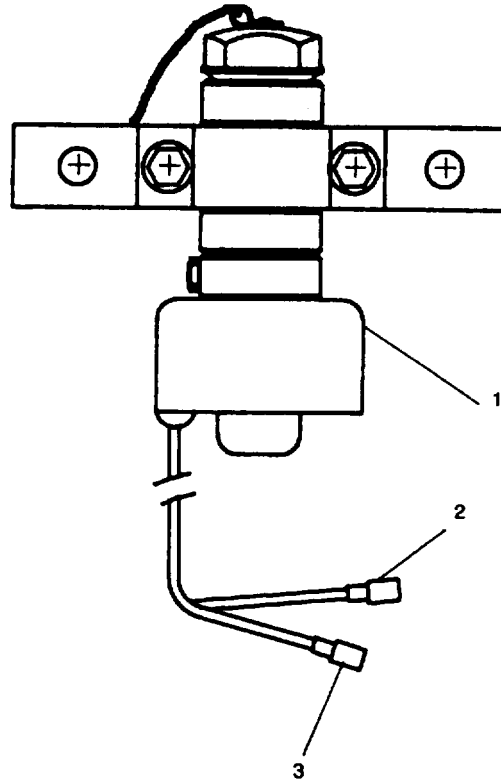

NOTES:

1. Refer to TM 9-6115-644-24P for materials required.
2. Solenoid wiring is not polarity sensitive, so position of terminals is not important.

PROCEDURES:

1. Strip 0.25 inch of insulation from end of each solenoid (1) lead.
2. Crimp terminal (2) on one end of solenoid (1) lead and terminal (3) on other end.

FIGURE D-24. Solenoid Assembly (P/N: 88-22553)

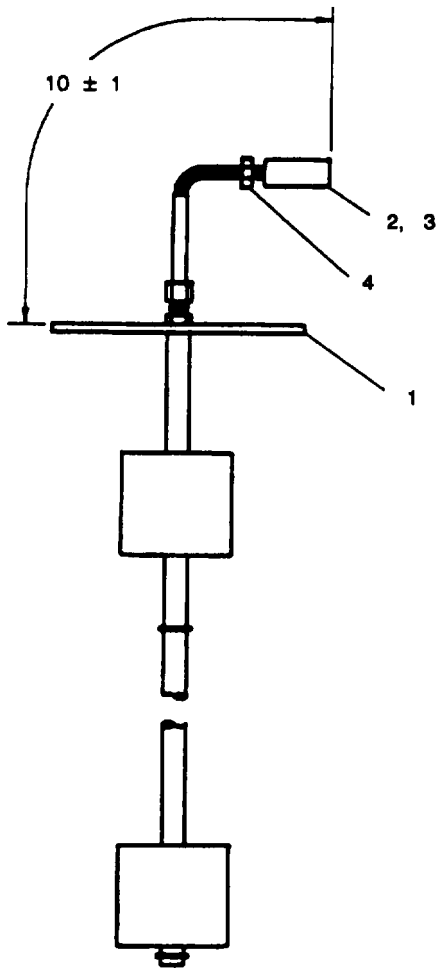

NOTES:

1. Dimensions shown are in inches.
2. Refer to TM 9-6115-644-24P for materials required.

PROCEDURES:

1. Strip 0.125 inch of insulation from end of each switch (1) lead.
2. Crimp pin (2) on end of each lead.
3. Insert pins into housing (3) with lead A in position 1, lead B in position 2, lead C in position 3, and lead D in position 4.
4. Mark "P12" on strap (4) and install in position shown.

FIGURE D-25. Switch Assembly, Fuel Level (P/N: 88-22548)

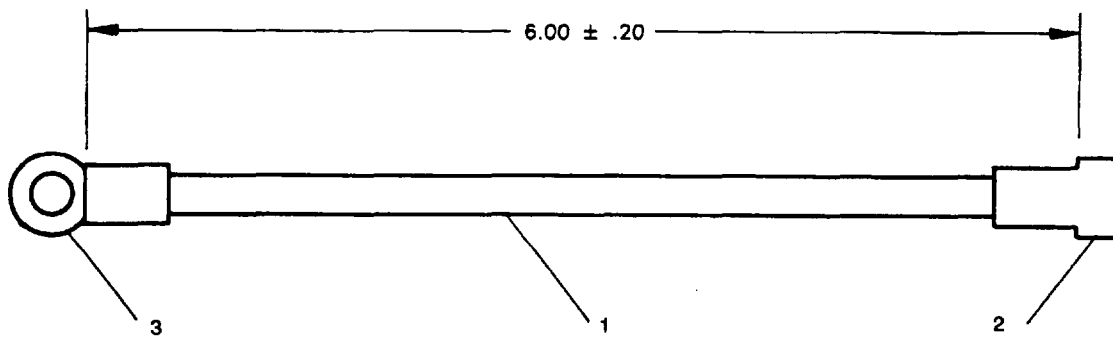

NOTES:

1. Dimensions shown are in inches.
2. Refer to TM 9-6115-644-24P for materials required.

PROCEDURES:

1. Cut wire (1) to length indicated.
2. Strip 0.50 inch from each end of wire (1).
3. Crimp terminal (2) on one end of wire (1) and terminal (3) on other end.

FIGURE D-26. Wire, Varistor (P/Ns: 88-20305-1 through 88-20305-3, and 88-20305-5)

TABLE D-1. INCHES TO METRIC CONVERSION

PART I. FRACTIONAL EQUIVALENT

Fractional Inches	Decimal Inches	mm
1/16	.0625	1.587
1/8	.1250	3.175
3/16	.1875	4.762
1/4	.2500	6.350
5/16	.3125	7.937
3/8	.3750	9.525
7/16	.4375	11.112
1/2	.5000	12.700
9/16	.5625	14.287
5/8	.6250	15.875
11/16	.6875	17.462
3/4	.7500	19.050
13/16	.8125	20.637
7/8	.8750	22.225
15/16	.9375	23.812
1	1	25.400

PART II. INCHES TO CENTIMETERS

Inches	cm
	2.540
2	5.080
3	7.620
4	10.16
5	12.70
6	15.24
7	17.78
8	20.32
9	22.86
10	25.40
20	50.80
30	76.20
40	101.6
50	127.0
60	152.4
70	177.8
80	203.2
90	228.6
100	254.0

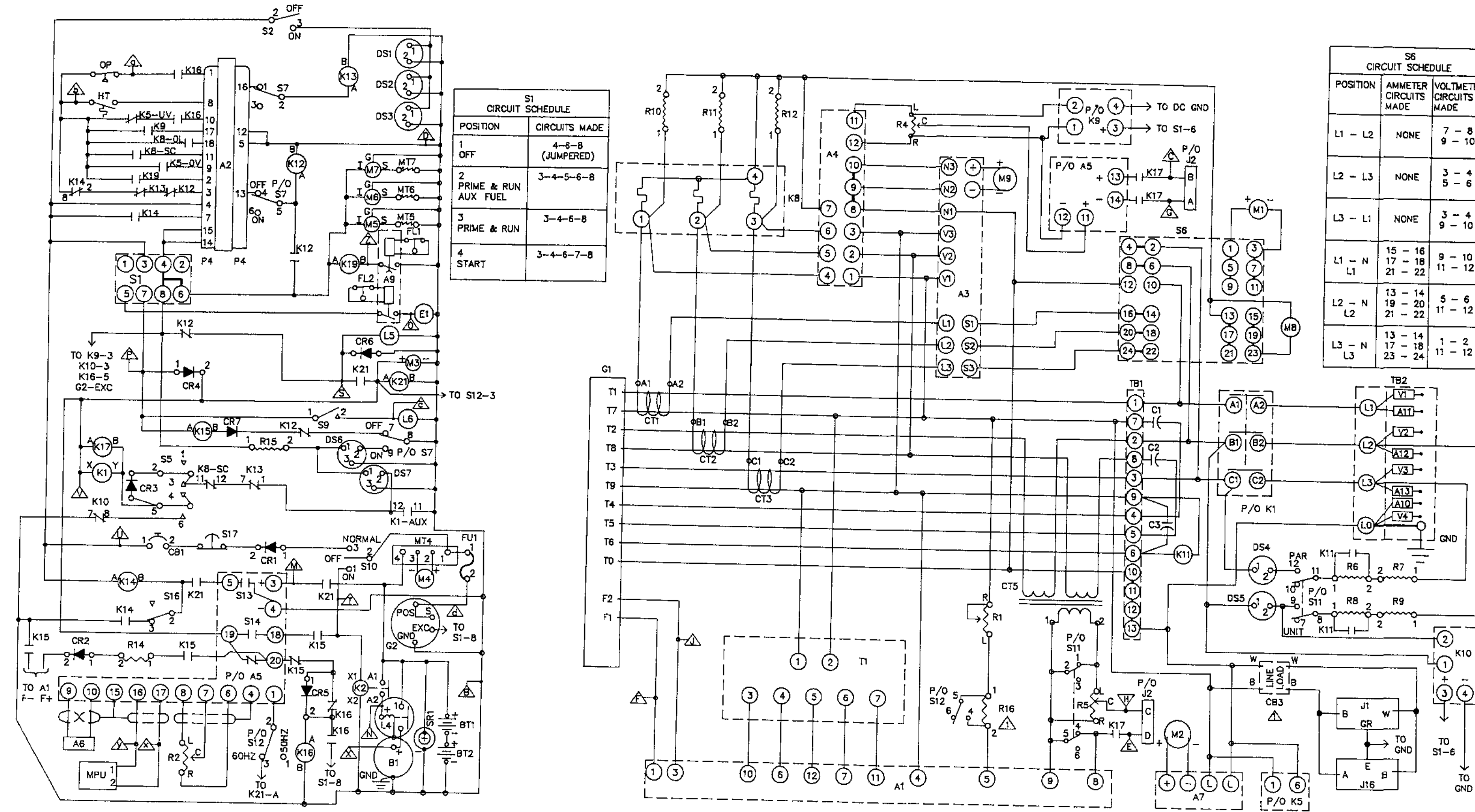

- A1 AC VOLTAGE REGULATOR
 - A2 MALFUNCTION INDICATOR
 - A3 KILOWATT TRANSDUCER
 - A4 LOAD MEASURING UNIT
 - A5 ELECTRONIC GOVERNOR CONTROL
 - A6 ELECTRONIC GOVERNOR ACTUATOR
 - A7 FREQUENCY TRANSDUCER
 - A8 RESISTOR ASSEMBLY
 - A9 FLOAT SWITCH MODULE
 - A10-A13 EMI FILTER
 - B1 CRANKING MOTOR
 - BT1 BATTERY 12V
 - BT2 BATTERY 12V
 - C1-C3 EMI CAPACITOR
 - CB1 DC CONTROL POWER CIRCUIT BREAKER
 - CB3 GROUND FAULT CIRCUIT INTERRUPTER
 - CBGND CONTROL BOX GROUND
 - CPGND CONTROL PANEL GROUND
 - CR1 DIODE REVERSE BATTERY
 - CR2 DIODE FIELD FLASH
 - CR3-7 DIODE BLOCKING
 - CR6 DIODE SUPPRESSING
 - CT1 CURRENT TRANSFORMER
 - CT2 CURRENT TRANSFORMER
 - CT3 DROOP CURRENT TRANSFORMER
 - CTS DROOP CURRENT TRANSFORMER
 - DS1 PANEL LIGHT
 - DS2 PANEL LIGHT
 - DS3 PANEL LIGHT
 - DS4 SYNCHRONIZATION LIGHT
 - DS5 SYNCHRONIZATION LIGHT
 - DS6 BATTLE SHORT LIGHT
 - DS7 AC CIRCUIT INTERRUPTER LIGHT
 - E1 AUXILIARY FUEL PUMP
 - FL1 LOW FUEL LEVEL FLOAT SWITCH
 - FL2 AUXILIARY FUEL PUMP FLOAT SWITCH
 - FU1 FUSE
 - G1 AC GENERATOR
 - G2 BATTERY CHARGING ALTERNATOR
 - GND GROUND
 - HT COOLANT HIGH TEMPERATURE SWITCH
 - J1 CONVENIENCE RECEPTACLE
 - J2 PARALLEL RECEPTACLE
 - J3 DIAGNOSTIC RECEPTACLE
 - J6 SWITCH BOX RECEPTACLE
 - K1 AC CIRCUIT INTERRUPTER
 - K2 CRANKING RELAY
 - K5 OVER / UNDER VOLTAGE RELAY
 - K8 OVERLOAD / SHORT CIRCUIT RELAY
 - K9 REVERSE POWER RELAY
 - K10 PERMISSIVE PARALLELING RELAY
 - K11 VOLTAGE SENSING RELAY
 - K12 ENGINE FAULT RELAY
 - K13 ELECTRICAL FAULT RELAY
 - K14 OVERSPEED RELAY
 - K15 START RELAY
 - K16 CRANK DISCONNECT RELAY
 - K17 K1 AUXILIARY RELAY
 - K19 FUEL LEVEL RELAY
 - K21 GOVERNOR CONTROL POWER
 - L0 OUTPUT TERMINAL
 - L1 OUTPUT TERMINAL
 - L2 OUTPUT TERMINAL
 - L3 STARTER SOLENOID
 - L4 OUTPUT TERMINAL
 - L5 FUEL SOLENOID VALVE
 - L6 ETHER SOLENOID VALVE
 - M1 AC VOLTMETER
 - M2 FREQUENCY METER
 - M3 TIME METER
 - M4 BATTERY CHARGING AMMETER
 - M5 FUEL LEVEL INDICATOR
 - M6 COOLANT TEMPERATURE INDICATOR
 - M7 OIL PRESSURE INDICATOR
 - M8 AC AMMETER
 - M9 KILOWATT METER
 - MPU MAGNETIC PICKUP
 - MT4 BATTERY CHARGING AMMETER SHUNT
 - MT5 FUEL LEVEL SENDER
 - MT6 COOLANT TEMPERATURE SENDER
 - MT7 OIL PRESSURE SENDER
 - OP LOW OIL PRESSURE SWITCH
 - P4 PLUG MALFUNCTION INDICATOR
 - R1 VOLTAGE ADJUST POTENTIOMETER
 - R2 FREQUENCY ADJUST POTENTIOMETER
 - R4 LOAD SHARING RHEOSTAT
 - R5 KVA SHARING RHEOSTAT
 - R6 SYNC LIGHTS DROPPING RESISTOR
 - R7 SYNC LIGHTS DROPPING RESISTOR
 - R8 SYNC LIGHTS DROPPING RESISTOR
 - R9 SYNC LIGHTS DROPPING RESISTOR
 - R10 BURDEN RESISTOR
 - R11 BURDEN RESISTOR
 - R12 BURDEN RESISTOR
 - R14 FIELD FLASH RESISTOR
 - R15 LED RESISTOR
 - R16 VOLTAGE ADJUST RESISTOR
 - S1 MASTER SWITCH
 - S2 PANEL LIGHT SWITCH
 - S5 AC CIRCUIT INTERRUPTER SWITCH
 - S6 AM / VM TRANSFER SWITCH
 - S7 BATTLE SHORT SWITCH
 - S9 ETHER START ASSIST SWITCH
 - S10 DEAD CRANK SWITCH
 - S11 UNIT-PARALLEL SWITCH
 - S12 FREQUENCY SELECTOR SWITCH
 - S13 OVERSPEED SWITCH
 - S14 CRANK DISCONNECT SWITCH
 - S16 OVERSPEED RESET SWITCH
 - S17 EMERGENCY STOP SWITCH
 - SR1 SLAVE RECEPTACLE
 - TR1 POTENTIAL TRANSFORMER
 - T8 TERMINAL BOARD (S)
 - TB1 VOLTAGE RECONNECTION TERMINAL BOARD
 - TB2 LOAD OUTPUT TERMINAL BOARD
 - V1-V4 VARISTOR AC LOAD LINES
- INDICATES PIN ON DIAGNOSTIC RECEPTACLE (J3)
- * LETTER DESIGNATION
- NOTE R16 AND S12 ARE NOT INCLUDED ON 400 HZ SETS

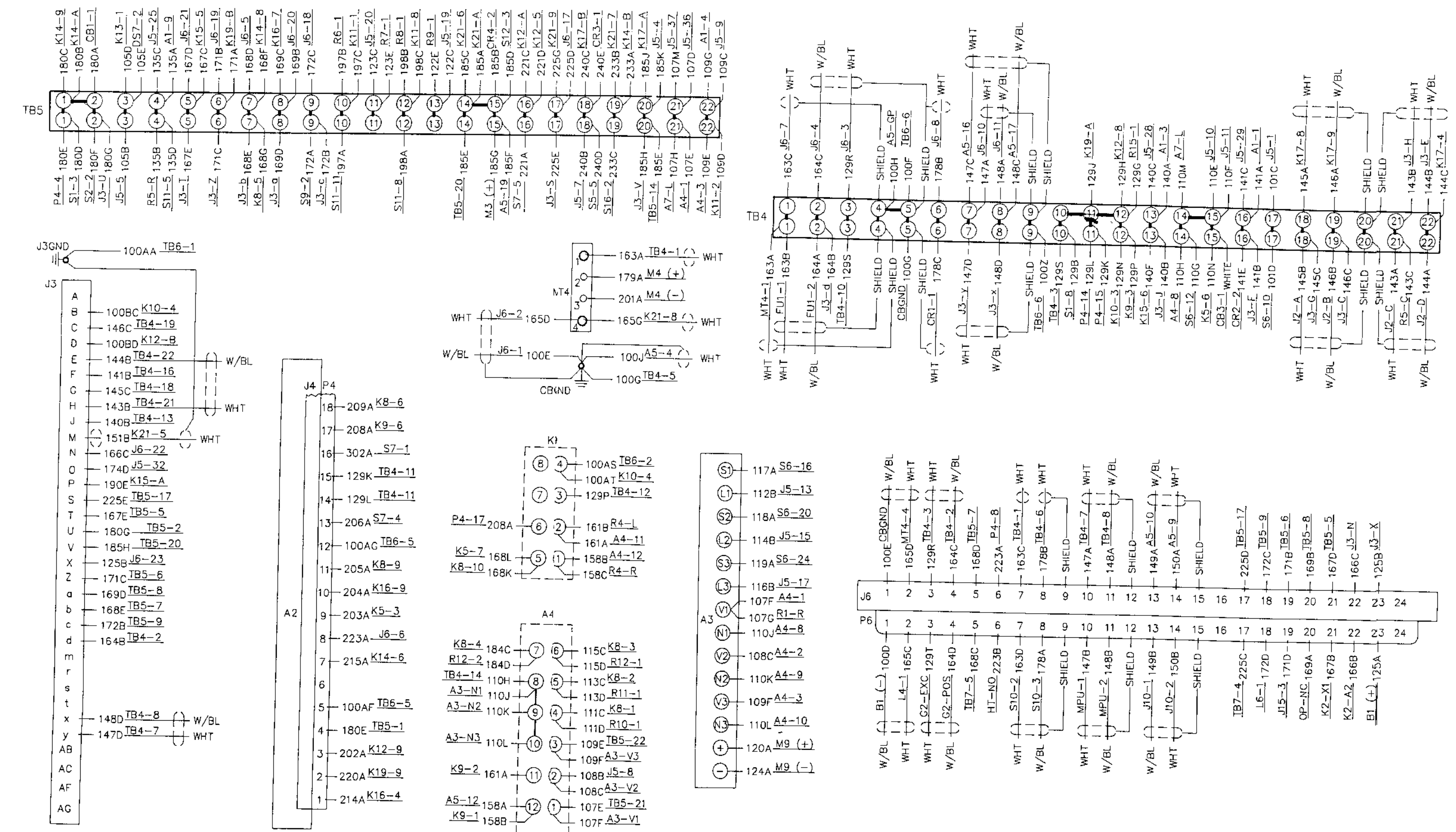

- | | | | |
|---------|----------------------------------|-------|-------------------------------------|
| A1 | AC VOLTAGE REGULATOR | K17 | K1 AUXILIARY RELAY |
| A2 | MALFUNCTION INDICATOR | K19 | FUEL LEVEL RELAY |
| A3 | KILOWATT TRANSDUCER | K21 | GOVERNOR CONTROL POWER |
| A4 | LOAD MEASURING UNIT | L0 | OUTPUT TERMINAL |
| A5 | ELECTRONIC GOVERNOR CONTROL | L1 | OUTPUT TERMINAL |
| A6 | ELECTRONIC GOVERNOR ACTUATOR | L2 | OUTPUT TERMINAL |
| A7 | FREQUENCY TRANSDUCER | L3 | OUTPUT TERMINAL |
| A8 | RESISTOR ASSEMBLY | L4 | STARTER SOLENOID |
| A9 | FLOAT SWITCH MODULE | L5 | FUEL SOLENOID VALVE |
| A10 A13 | EMI FILTER | L6 | ETHER SOLENOID VALVE |
| B1 | CRANKING MOTOR | M1 | AC VOLTMETER |
| BT1 | BATTERY 12V | M2 | FREQUENCY METER |
| BT2 | BATTERY 12V | M3 | TIME METER |
| C1 C3 | EMI CAPACITOR | M4 | BATTERY CHARGING AMMETER |
| CB1 | DC CONTROL POWER CIRCUIT BREAKER | M5 | FUEL LEVEL INDICATOR |
| CB3 | GROUND FAULT CIRCUIT INTERRUPTER | M6 | COOLANT TEMPERATURE INDICATOR |
| CBGND | CONTROL BOX GROUND | M7 | OIL PRESSURE INDICATOR |
| CPGND | CONTROL PANEL GROUND | M8 | AC AMMETER |
| CR1 | DIODE REVERSE BATTERY | M9 | KILOWATT METER |
| CR2 | DIODE FIELD FLASH | MPU | MAGNETIC PICKUP |
| CR3 7 | DIODE BLOCKING | MT4 | BATTERY CHARGING AMMETER SHUNT |
| CT1 | CURRENT TRANSFORMER | MT5 | FUEL LEVEL SENDER |
| CT2 | CURRENT TRANSFORMER | MT6 | COOLANT TEMPERATURE SENDER |
| CT3 | CURRENT TRANSFORMER | MT7 | OIL PRESSURE SENDER |
| CT5 | DROOP CURRENT TRANSFORMER | OP | LOW OIL PRESSURE SWITCH |
| DS1 | PANEL LIGHT | P4 | PLUG MALFUNCTION INDICATOR |
| DS2 | PANEL LIGHT | R1 | VOLTAGE ADJUST POTENTIOMETER |
| DS3 | PANEL LIGHT | R2 | FREQUENCY ADJUST POTENTIOMETER |
| DS4 | SYNCHRONIZATION LIGHT | R4 | LOAD SHARING RHEOSTAT |
| DS5 | SYNCHRONIZATION LIGHT | R5 | KVA SHARING RHEOSTAT |
| DS6 | BATTLE SHORT LIGHT | R6 | SYNC LIGHTS DROPPING RESISTOR |
| DS7 | AC CIRCUIT INTERRUPTER LIGHT | R7 | SYNC LIGHTS DROPPING RESISTOR |
| E1 | AUXILIARY FUEL PUMP | R8 | SYNC LIGHTS DROPPING RESISTOR |
| FL1 | LOW FUEL LEVEL FLOAT SWITCH | R9 | SYNC LIGHTS DROPPING RESISTOR |
| FL2 | AUXILIARY FUEL PUMP FLOAT SWITCH | R10 | BURDEN RESISTOR |
| FU1 | FUSE | R11 | BURDEN RESISTOR |
| G1 | AC GENERATOR | R12 | BURDEN RESISTOR |
| G2 | BATTERY CHARGING ALTERNATOR | R14 | FIELD FLASH RESISTOR |
| GND | GROUND | R15 | LED RESISTOR |
| HT | COOLANT HIGH TEMPERATURE SWITCH | R16 | VOLTAGE ADJUST RESISTOR |
| J1 | CONVENIENCE RECEPTACLE | S1 | MASTER SWITCH |
| J2 | PARALLEL RECEPTACLE | S2 | PANEL LIGHT SWITCH |
| J3 | DIAGNOSTIC RECEPTACLE | S5 | AC CIRCUIT INTERRUPTER SWITCH |
| J16 | SWITCH BOX RECEPTACLE | S6 | AM/VM TRANSFER SWITCH |
| K1 | AC CIRCUIT INTERRUPTER | S7 | AC/VM TRANSFER SWITCH |
| K2 | CRANKING RELAY | S9 | BATTLE SHORT SWITCH |
| K5 | OVER/UNDER VOLTAGE RELAY | S9 | ETHER START ASSIST SWITCH |
| K8 | OVERLOAD/SHORT CIRCUIT RELAY | S10 | DEAD CRANK SWITCH |
| K9 | REVERSE POWER RELAY | S11 | UNIT PARALLEL SWITCH |
| K10 | PERMISSIVE PARALLELING RELAY | S12 | FREQUENCY SELECTOR SWITCH |
| K11 | VOLTAGE SENSING RELAY | S13 | OVERSPEED SWITCH |
| K12 | ENGINE FAULT RELAY | S14 | CRANK DISCONNECT SWITCH |
| K13 | ELECTRICAL FAULT RELAY | S16 | OVERSPEED RESET SWITCH |
| K14 | OVERSPEED RELAY | S17 | EMERGENCY STOP SWITCH |
| K15 | START RELAY | SR1 | SLAVE RECEPTACLE |
| K16 | CRANK DISCONNECT RELAY | T1 | POTENTIAL TRANSFORMER |
| | | TB | TERMINAL BOARD (S) |
| | | TB1 | VOLTAGE RECONNECTION TERMINAL BOARD |
| | | TB2 | LOAD OUTPUT TERMINAL BOARD |
| | | V1 V4 | VARISTOR AC LOAD LINES |
| | | | VARISTOR DC SYSTEM |

NOTE SIZE DESIGNATOR OMITTED FROM WIRE NUMBERS FOR CLARITY

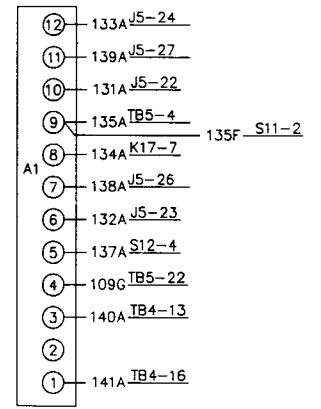
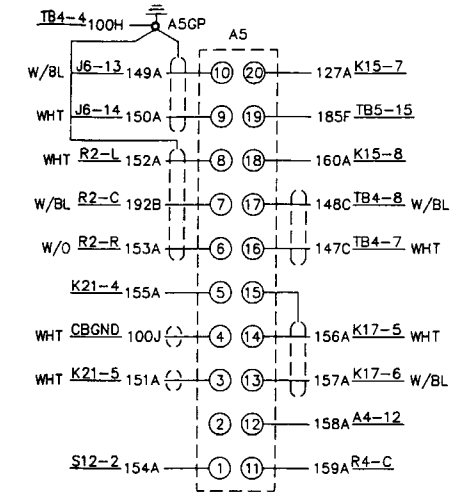
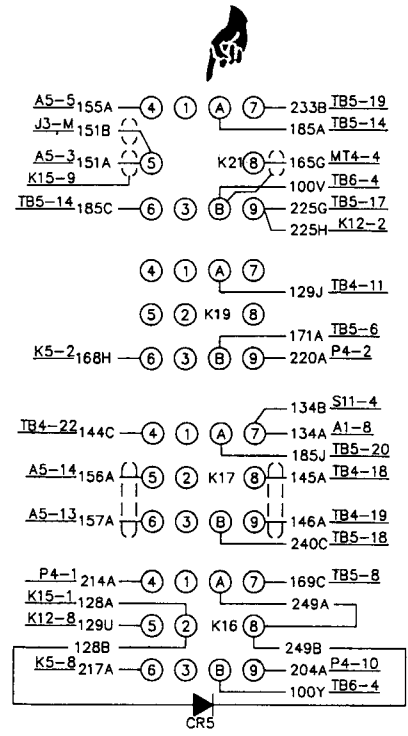
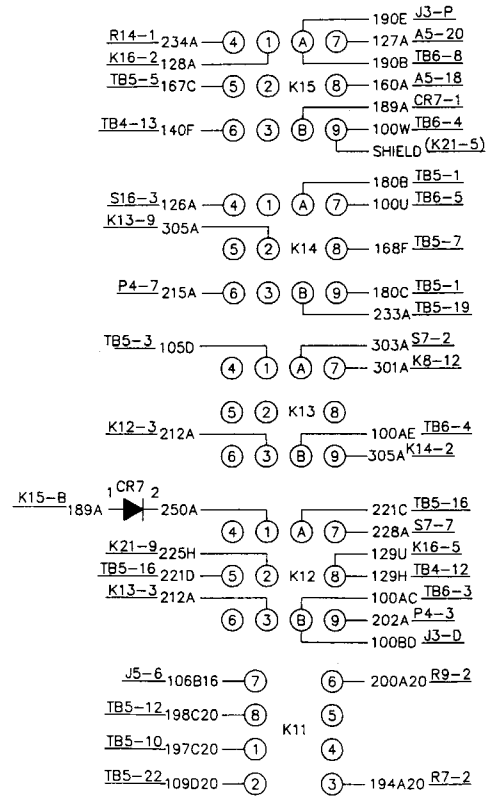
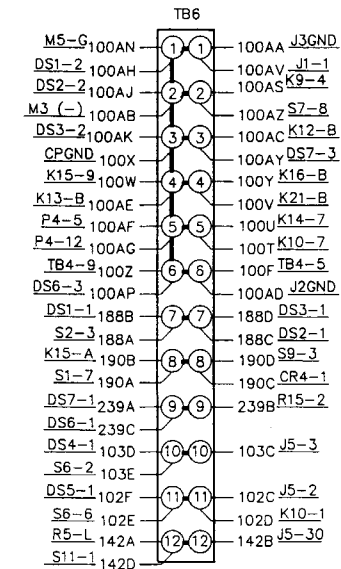
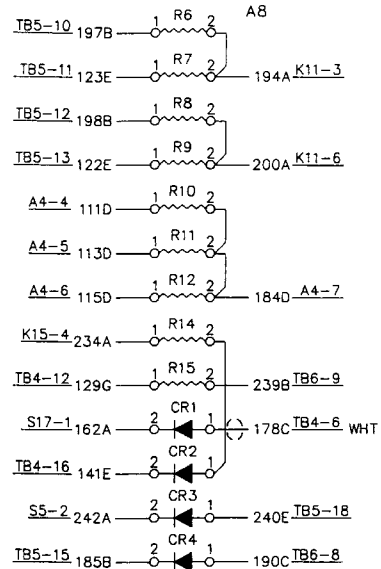

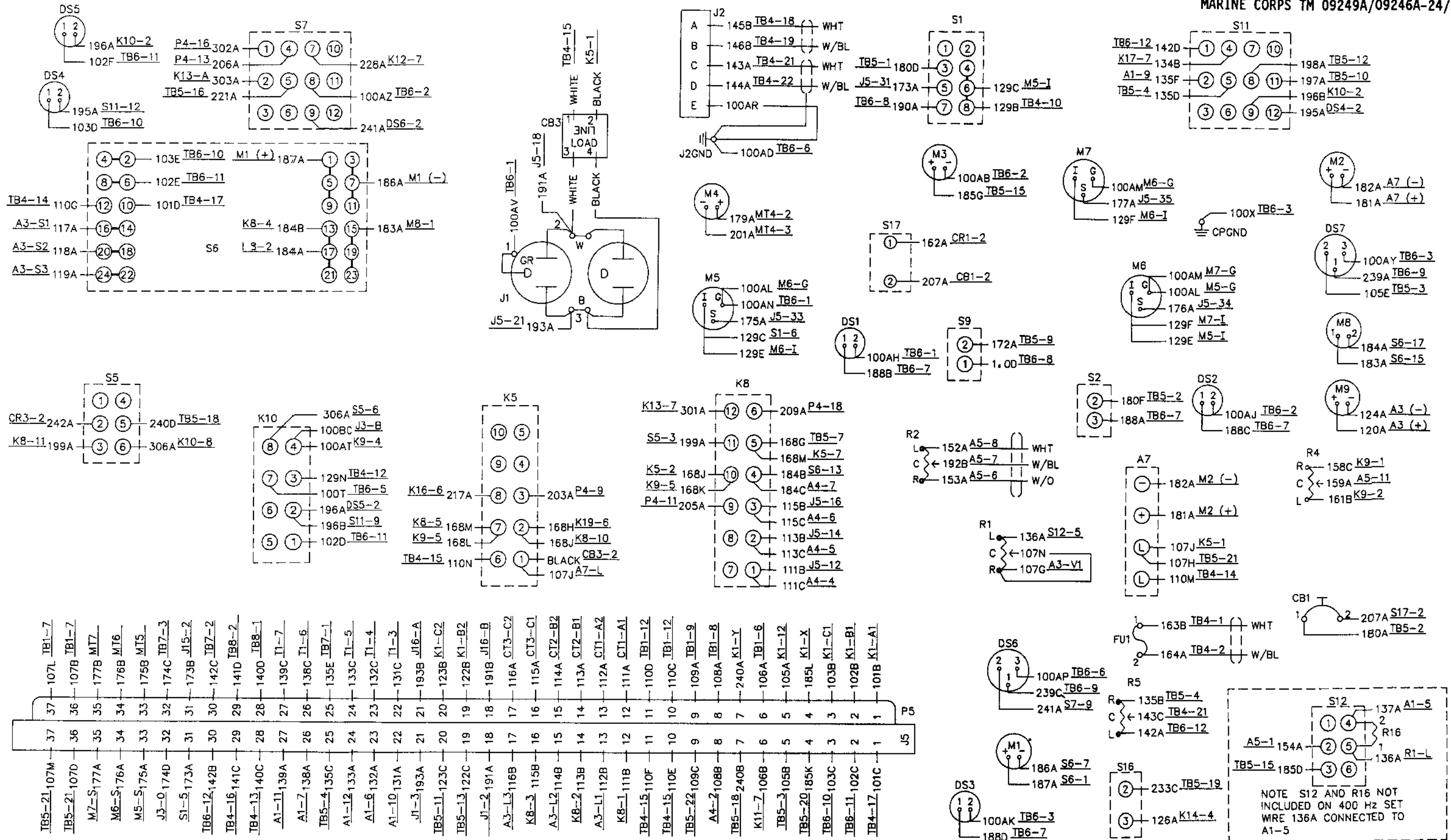

FO-2 Wiring Diagram (Sheet 3 of 4)
 FP-7/(FP-8 blank)

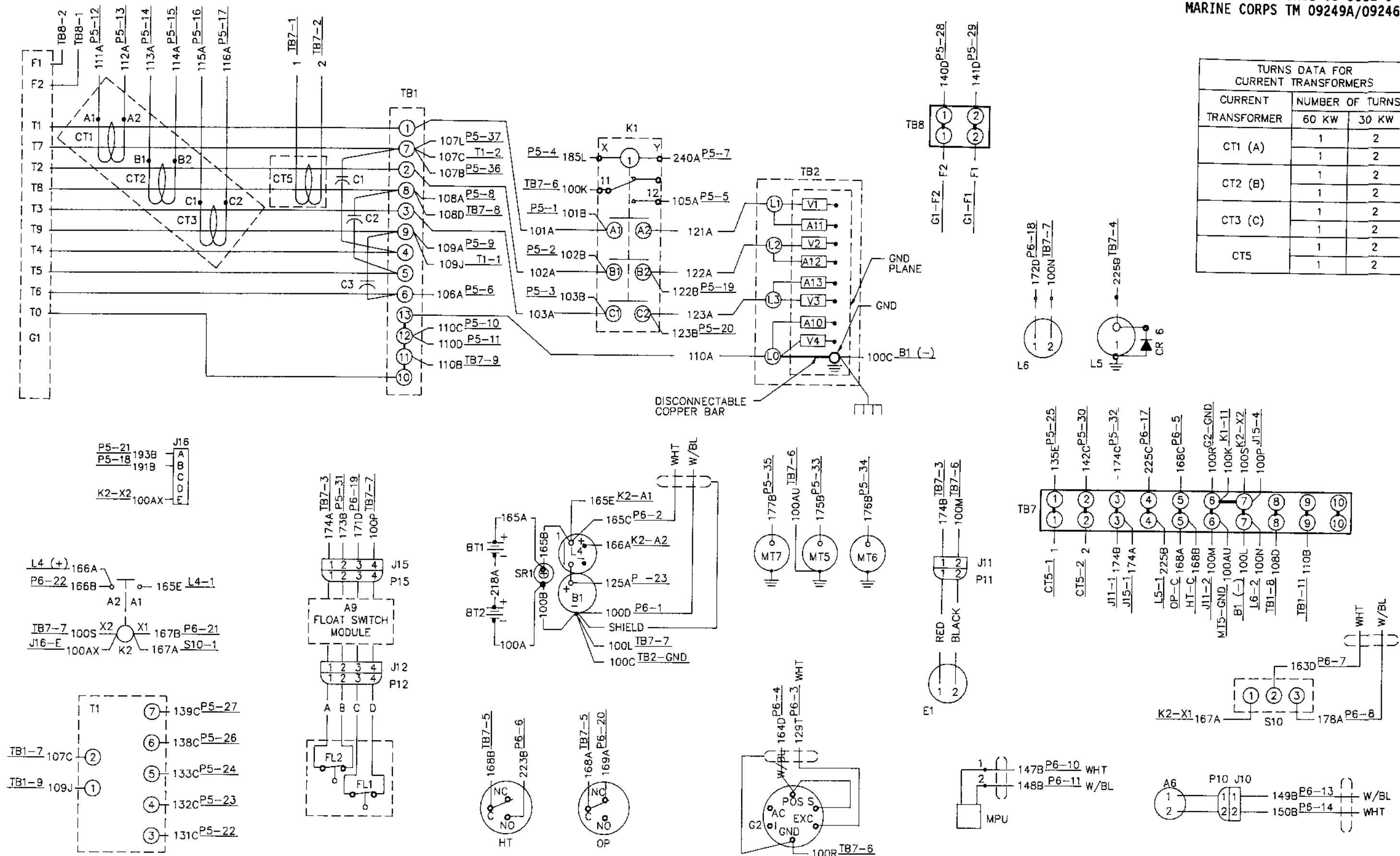

URNS DATA FOR CURRENT TRANSFORMERS

CURRENT TRANSFORMER	NUMBER OF TURNS	
	60 KW	30 KW
CT1 (A)	1	2
CT2 (B)	1	2
CT3 (C)	1	2
CT5	1	2

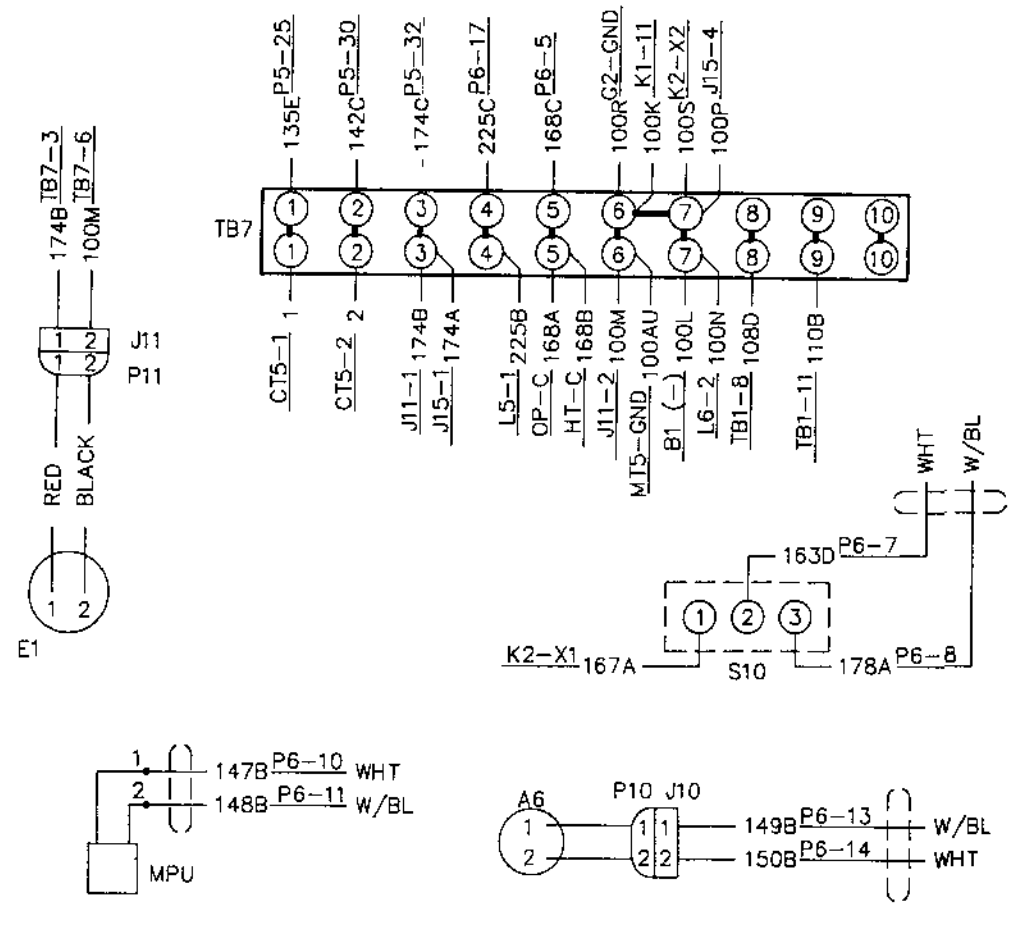
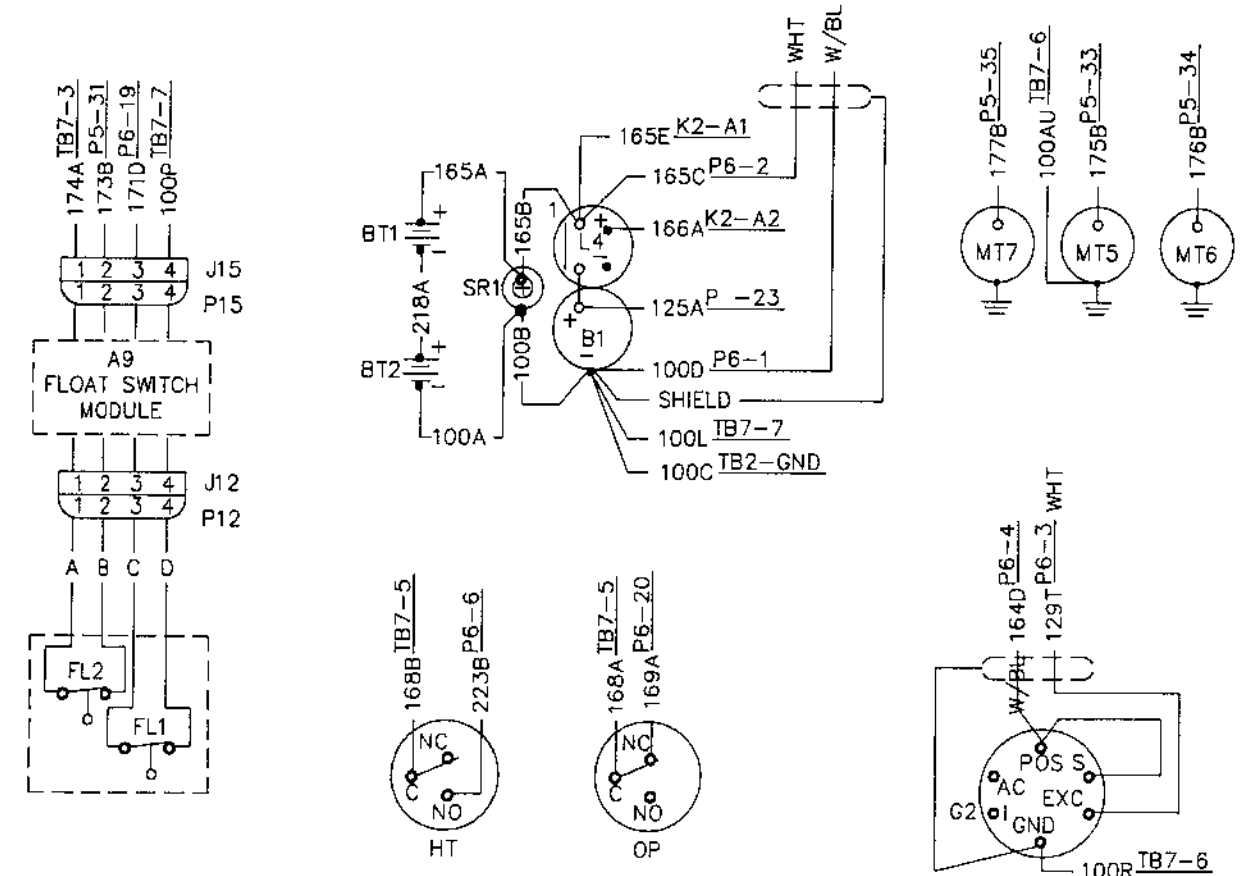
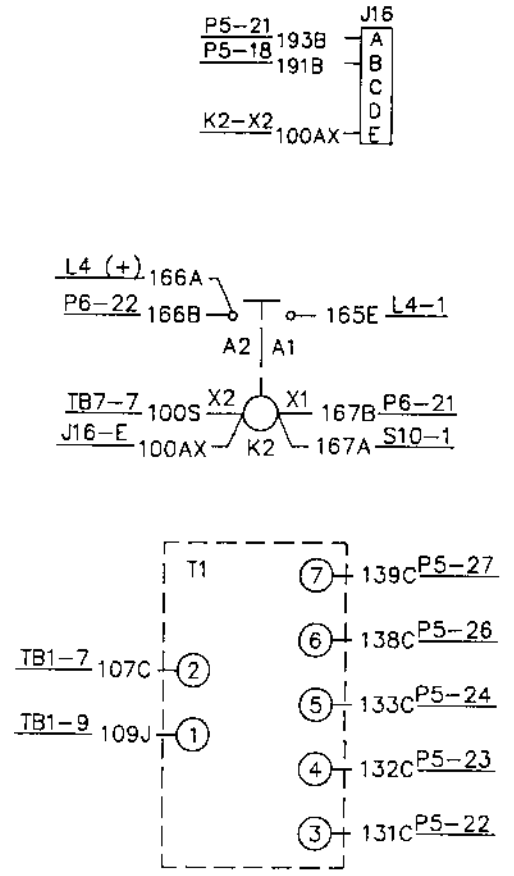

INDEX

Subject	Paragraph, Figure, Table, Number
A	
AC Circuit Interrupter Relay	
Inspection	2-101-1
Installation	2-101-4
Removal	2-101-3
Testing	2-101-2
AC Circuit Interrupter Switch	
Inspection	2-37-1
Installation	2-37-4
Removal	2-37-3
Testing	2-37-2
AC Generator	
Description	4-15
Installation	4-16-2
Location	1-13-18
Removal	4-16-1
AC Voltage Regulator	
Installation	4-1-5
Removal	4-1-4
Testing (400 HZ)	4-1-3
Testing (50/60 HZ) (P/N 122-3005)	4-1-1
Testing (50/60 HZ) (P/N19880-001)	4-1-2
AC Voltmeter (VOLTS AC)	
Inspection	2-31-1
Installation	2-31-4
Removal	2-31-3
Testing	2-31-2
Access Doors	
Inspection	2-14-2
Installation	2-14-4
Removal	2-14-1
Repair	2-14-3
Air Cleaner Assembly	
Description	1-13-17
Inspection	2-73-1
Installation	2-73-4
Location	1-13-17
Removal	2-73-3
Service	2-73-2
Air Cleaner Tubing and Breather	
Inspection	2-75-1
Installation	2-75-4
Service	2-75-2
Air Cleaner Tubing and Breather, Removal	2-75-3

Subject

A - Continued

Air Filter Element, Installation	2-74-3
Air Filter Element	
Inspection	2-74-2
Removal	2-74-1
Air Restriction Indicator, Installation	2-72-3
Air Restriction Indicator	
Inspection	2-72-1
Removal	2-72-2
AM-VM Transfer Switch	
Inspection	2-39-1
Installation	2-39-4
Removal	2-39-2
Testing	2-39-3
Ammeter (PERCENT RATED CURRENT)	
Inspection	2-29-1
Installation	2-29-4
Removal	2-29-3
Testing	2-29-2
Auxiliary Fuel Pump	
Inspection	2-87-1
Installation	2-87-4
Removal	2-87-3
Testing	2-87-2

B

Batteries	
Description	1-13-24
Inspection	2-12-3
Installation	2-12-4
Location	1-13-24
Removal	2-12-2
Service	2-12-4
Testing	2-12-1
BATTERY CHARGE Ammeter	
Inspection	2-27-1
Installation	2-27-4
Removal	2-27-3
Testing	2-27-2
BATTERY CHARGER FUSE	
Inspection	2-49-2
Installation	2-49-3
Removal	2-49-1

Subject	Paragraph, Figure, Table, Number
B - Continued	
Battery Charging Alternator	
Description	1-13-6
Location	1-13-6
BATTLE SHORT Switch	
Inspection	2-36-1
Installation	2-36-4
Removal	2-36-3
Testing	2-36-2
C	
Control Box Assembly	
Inspection	2-19-1
Installation	2-19-4
Removal	2-19-2
Repair	2-19-3
Control Box Harness	
Inspection, Direct Support	4-3-2
Inspection, Unit	2-62-1
Installation	4-3-5
Removal	4-3-1
Repair, Direct Support	4-3-4
Repair, Unit	2-62-3
Testing, Direct Support	4-3-3
Testing, Unit	2-62-2
Control Box Side Panels	
Installation	2-69-4
Removal	2-69-1
Repair	2-69-3
Control Box Side Pansels, Inspection	2-69-2
Control Box Top Panel	
Inspection	2-15-2
Installation	2-15-4
Removal	2-15-1
Repair	2-15-3
Control Box Tray (Bottom)	
Inspection	2-70-2
Installation	2-70-4
Removal	2-70-1
Repair	2-70-3
Control Panel Assembly	
Inspection	2-67-2
Installation	2-67-4
Location	1-13-2
Removal	2-67-1
Repair	2-67-3

Subject

C-Continued

Control Panel Frame	
Inspection	2-68-2
Installation	2-68-4
Removal	2-68-1
Repair	2-68-3
Control Panel Lights	
Assembly	2-20-4
Disassembly	2-20-3
Inspection	2-20-1
Installation	2-20-5
Removal	2-20-2
Convenience Receptacle	
Inspection	2-46-1
Installation	2-46-4
Location	1-13-14
Removal	2-46-3
Testing	2-46-2
Convenience Receptacle, Description	1-13-14
Coolant High Temperature Switch	
Cleaning	2-109-3
Inspection	2-109-3
Installation	2-109-4
Removal	2-109-2
Testing	2-109-1
Coolant Overflow and Drain Hoses	
Inspection	2-81-2
Installation	2-81-3
Removal	2-81-1
Coolant Recovery System	
Inspection	2-85-1
Installation	2-85-3
Removal	2-85-2
Coolant System	
Description	1-12-4
Service	2-76-2
Testing	2-76-1
COOLANT TEMP. Indicator, inspection	2-24-1
COOLANT TEMP. Indicator	
Installation	2-24-4
Removal	2-24-3
Testing	2-24-2

Subject	Paragraph, Figure, Table, Number
---------	--

C - Continued

Coolant Temperature Sender	
Cleaning	2-108-3
Inspection.....	2-108-3
Installation	2-108-4
Removal	2-108-2
Testing	2-108-1
Cooling Fan	
Inspection	2-83-2
Installation	2-83-3
Removal	2-83-1
Cranking Relay	
Inspection	2-102-1
Installation	2-102-4
Removal	2-102-3
Testing	2-102-2
Current Transformer	
Inspection	2-98-1
Installation	4-10-3
Removal	4-10-1
Testing, Direct Support	4-10-2
Testing, Unit	2-98-2

D

DC Control Power Circuit Breaker	
Inspection	2-50-1
Installation	2-50-4
Removal	2-50-3
Testing	2-50-2
DEAD CRANK Switch	
Description	1-13-21
Installation	2-111-3
Location	1-13-21
Removal	2-111-2
Testing	2-111-1
Destruction of Materiel to Prevent Enemy Use	
	1-7
Diagnostic Connector	
Description	1-13-16
Inspection	2-63-1
Installation	2-63-3
Location	1-13-16
Removal	2-63-2
Differences Between Models	
	1-10

Subject Paragraph,
Figure, Table,
Number

D-Continued

Diode Assembly	
Installation	2-112-4
Removal	2-112-1
Repair	2-112-3
Testing	2-112-2
Diodes, Rotating Rectifier	
Installation	4-17-3
Removal	4-17-2
Testing	4-17-1
Dipstick	
Description	1-13-8
Location	1-13-8
Droop Current Transformer	
Inspection	2-99
Installation	4-11-3
Removal	4-11-1
Testing	4-11-2

E

EMERGENCY STOP Switch	
Inspection	2-41-1
Installation	2-41-4
Removal	2-41-2
Testing	2-41-3
End Bell and Main Bearing	
Installation	4-18-2
Removal	4-18-1
Engine and Generator Assembly	
Description	3-10
Installation	3-11
Removal	3-10
Engine Assembly	
Installation	3-23
Location	1-13-20
Removal	3-13
Replacement	3-26
Engine Oil Drain Line	
Inspection	2-113-1
Installation	2-113-3
Removal	2-113-2
Equipment Characteristics, Capabilities and Features	1-1

Subject	Paragraph, Figure, Table, Number
---------	--

E - Continued

Ether Cylinder	
Inspection	2-94-2
Installation	2-94-3
Removal	2-94-1
Ether Solenoid Valve	
Inspection	2-95-2
Installation	2-95-3
Removal	2-95-1
ETHER Switch	
Inspection	2-33-1
Installation	2-33-4
Removal	2-33-2
Testing	2-33-3
Exciter Rotor	4-21
Description	4-15-3
Exciter Stator	
Installation	4-20-3
Removal	4-20-2
Testing	4-20-1

F

Fabrication of Tools and Equipment, Direct and General Support	3-1
Fabrication/Assembly of Parts	2-3
Fan Belt	
Adjustment	2-84-2
Description	1-13-5
Inspection	2-84-1
Installation	2-84-4
Location	1-13-5
Removal	2-84-3
Testing	2-84-2
Fan Guardes, Installation	2-78-3
Fan Guards	
Inspection	2-78-1
Removal	2-78-2
FREQUENCY Adjust Potentiometer	
Inspection	2-35-1
Installation	2-35-4
Removal	2-35-2
Testing	2-35-3

Subject

F - Continued

Frequency Meter (HERTZ)	
Inspection	2-28-1
Installation	2-28-5
Removal	2-28-4
Testing (400 Hz).....	2-28-3
Testing (50/60 Hz)	2-28-2
FREQUENCY SELECT SWITCH, Testing	2-45-2
FREQUENCY SELECT Switch	
Inspection	2-45-1
Installation	2-45-4
Removal	2-45-3
Frequency Transducer	
Inspection	2-52-1
Installation	2-52-5
Removal	2-52-4
Testing (400 Hz)	2-52-3
Frequency Transducer, Testing (50/60 Hz)	2-52-2
Front Housing Section	
Inspection	2-17-2
Installation	2-17-4
Removal	2-17-1
Repair	2-17-3
Fuel Drain Valve	
Installation	2-89-2
Removal	2-89-1
Fuel Filter/Water Separator	
Description	1-13-10
Location	1-13-10
Fuel Float Module	
Inspection	2-93-1
Installation	2-93-4
Removal	2-93-3
Testing	2-93-2
Fuel Level Indicator	
Inspection	2-23-1
Installation	2-23-4
Removal	2-23-3
Testing	2-23-2
Fuel Level Sender	
Inspection	2-90-1
Installation	2-90-4
Removal	2-90-2
Testing	2-90-3

Subject	Paragraph, Figure, Table, Number
---------	--

F - Continued

Fuel Pickup	
Inspection	2-92-2
Installation	2-92-3
Removal	2-92-1
Fuel Tank	
Description	1-13-19
Inspection	4-6-1
Installation	4-6-3
Location	1-13-19
Removal	4-6-2
Service	2-1-2-3
Fuel Tank Filler Neck	
Inspection	2-88-2
Installation	2-88-3
Removal	2-88-1

G

Generator Assembly, AC	
Description	4-15
Installation	4-16-2
Location	1-13-18
Removal	4-16-1
Generator Set	
Description	1-8
Installation	2-2
Governor Actuator	
Adjustment	4-14-4
Description	1-12-9
Installation	4-14-3
Removal	4-14-2
Testing	4-14-1
Governor Control Unit	
Adjustment	4-2-3
Description	1-12-9
Inspection	2-61-1
Installation	2-61-3
Removal	2-61-2
Replacement	4-2-4
Testing	4-2-2
Ground Fault Circuit Interrupter	
Inspection	2-47-1
Installation	2-47-4
Removal	2-47-3
Testing	2-47-2

Subject	Paragraph, Figure, Table, Number
I	
Inspecting and Servicing the Equipment	2-1
Interference Suppression Components	
Primary	2-8-1
Secondary	2-8-2
K	
Kilowatt Meter (PERCENT POWER)	
Inspection	2-30-1
Installation	2-30-4
Removal	2-30-3
Testing	2-30-2
Kilowatt Transducer	
Inspection	2-53-1
Installation	2-53-4
Removal	2-53-3
Kilowatt Transducer, Testing	2-53-2
L	
Levels of Maintenance	1-6
Load Measuring Unit	
Description	1-12-9
Inspection	2-65-1
Installation	2-65-3
Replacement	4-4-2
Testing	4-4-1
Load Output Terminal Board Assembly	
Description	1-13-12
Inspection	2-103-2
Installation	2-103-4
Location	1-13-12
Removal	2-105-1
Repair	2-103-3
Load Output Terminals	
Description	1-13-12
Inspection	2-104-2
Installation	2-104-3
Location	1-13-12
Removal	2-104-1
LOAD SHARING ADJUST Rheostat	
Inspection	2-43-1
Installation	2-43-4
Removal	2-43-3
Testing	2-43-2

Subject	Paragraph, Figure, Table, Number
L - Continued	
Location and Description of Major Components	1-13
Low Fuel Level /Auxiliary Fuel Pump float Switch, Removal	2-91-2
Low Fuel Level/Auxiliary Fuel Pump Float Switch	
Installation	2-91-4
Testing	2-91-3
Low Fule Level/Auxiliary Fuel Pump float Switch, Inspection	2-91-1
Low Oil Pressure Switch	
Cleaning	2-106-3
Inspection	2-106-3
Installation	2-1064
Removal	2-106-2
Testing	2-106-1
Low Pressure Fuel Lines and Fittings, Installation	2-86-1
Lower Coolant Hose	
Cleaning	2-80-2
Inspection	2-80-2
Installation	2-80-3
Removal	2-80-1
Lower Pressure Fuel Lines and Fittings, Removal	2-86-1
Lubricating Oil, Servicing of.....	2-1-2-4

M

Magnetic Pickup	
Adjustment	2-110-4
Cleaning	2-110-2
Inspection	2-110-2
Installation	2-110-3
Removal	2-110-1
Main Rotor Assembly	
Installation	4-22-3
Removal	4-22-2
Testing	4-22-1
Main Stator Assembly	
Installation	4-23-3
Removal	4-23-2
Testing	4-23-1
Maintenance Forms and Records	1-3
Major Components, Location and Description of	1-13
Malfunction indicator Panel	
Description	1-13-1
Inspection	2-48-1
Installation	1-13-1

Subject	Paragraph, Figure, Table, Number
M - Continued	
Malfunction Indicator Panel - Continued	
Location	1-13-1
Removal	2-48-3
Testing	2-48-2
Marking, for Shipment and Storage	2-116
MASTER SWITCH	
Inspection	2-32-1
Installation	2-32-4
Removal	2-32-2
Testing	2-32-3
Model Numbers and Equipment Names	1-1
Muffler	
Description	1-13-3
Inspection	2-71
Installation	2-71-3
Location	1-13-3
Removal	2-71-1
N	
NATO Slave Receptacle	
Description	1-13-4
Inspection	2-13-1
Installation	2-13-3
Location	1-13-4
Removal	2-13-2
Nuclear, Biological, Chemical Contamination	2-9
O	
Oil Filter	
Description	1-13-7
Location	1-13-7
OIL PRESSURE Indicator	
Inspection	2-25-1
Installation	2-25-4
Removal	2-25-3
Testing	2-25-2
Oil Pressure Sender	
Cleaning	2-107-3
Inspection	2-107-3
Installation	2-107-4
Removal	2-107-2
Testing	2-107-1

Subject	Paragraph, Figure, Table, Number
O - Continued	
Output Box Panels, Inspection	4-13-1
Output Assembly	
Removal	4-7-2 4-7-1
Output Box Harness	
Inspection, Direct Support	4-9-1
Inspection, Unit	2-97-1
Installation	4-9-5
Removal	4-9-2
Repair, Direct Support	4-9-4
Repair, Unit	2-97-3
Testing, Direct Support	4-9-3
Testing, Unit	2-97-2
Output Box Panels, Removal	4-13-2
Output Box Panels	
Installation	4-13-4
Repair	4-13-3
Over/Under Voltage Relay	
Inspection	2-55-1
Installation	2-55-4
Removal	2-55-3
Testing	2-55-2
Overspeed Reset Switch	
Inspection	2-44-1
Installation	2-44-4
Removal	2-44-3
Testing	2-44-2

P

Packing, for Shipment and Storage	2-115
Panel Lights	
Assembly	2-20-4
Disassembly	2-20-3
Inspection	2-20-1
Installation	2-20-5
Removal	2-20-2
PANEL LIGHTS Switch	
Inspection	2-40-1
Installation	2-40-4
Removal	2-40-2
Testing	2-40-3

Paragraph,
 Figure, Table,
 Number

Subject

P - Continued

Parallel Connector	
Description	1-13-15
Inspection	2-64-1
Installation	2-64-3
Location	1-13-15
Removal	2-64-2
PARALLEL-UNIT Switch	
Inspection	2-38-1
Installation	2-38-4
Removal	2-38-2
Testing	2-38-3
Permissive Paralleling Relay	
Inspection	2-57-1
Installation	2-57-4
Removal	2-57-3
Testing	2-57-2
PMCS Procedures	2-5
Power Potential Transformer	
Inspection	2-100
Installation	4-12-4
Removal	4-12-1
Testing (P/N 17910)	4-12-3
Testing (P/N A1497B)	4-12-3
Preservation, for Shipment and Storage	2-114
Press to Test Light, inspection	2-21-1
Press to Test Lights	
Installation	2-21-4
Removal	2-21-3
Testing	2-21-2
Principles of Operation	
Applying the Load	1-12-8-4
Engine Air Intake and Exhaust System	1-12-6
Engine Cooling System	1-12-4
Engine Lubrication System	1-12-5
Engine Starting System	1-12-8-1
Fault System	1-12-1
Field Flash	1-12-8-2
Fuel System	1-12-2
Generator Set Cooling System	1-12-3
Governor Control System	1-12-9
Operation	1-12-8-3
Output Supply System	1-12-7
Paralleling	1-12-8-6
Shutdown	1-12-8-5
Voltage Regulation System	1-12-10

Subjet	Paragraph, Figure, Table, Number
R	
Radiator	
Cleaning	2-82-2
Description	1-13-23
Inspection	2-82-2
Installation	2-82-4
Location	1-13-23
Removal	2-82-1
Repair, Direct Support	4-5
Repair, Unit	2-82-3
Service	2-1-2-2
Radiator Filler and Panel, Installation	2-77-3
Radiator Filler Hose and Panel	
Cleaning	2-77-2
Removal	2-77-1
Radiator Filler hose and Panel, Inspection	2-77-2
REACTIVE CURRENT ADJUST Rheostat	
Inspection	2-42-1
Installation	2-42-4
Removal	2-42-3
Testing	242-2
Rear Housing Section, Installation	2-18-4
Rear Housing Section	
Inspection	2-18-2
Removal	2-18-1
Repair	2-18-3
Relays	
Inspection	2-60-1
Installation	2-60-4
Removal	2-60-3
Testing	2-60-2
Reporting Equipment improvement Recommendations(EIRs)	1-5
Reporting of Errors	1-4
Resister-Dale Assembly, Inspection	2-66-1
Resistor-Diode Assembly	
Installation.....	2-66-5
Removal	2-66-3
Repair	2-66-4
Testing	2-66-2
Reverse Power Relay	
Inspection	2-58-1
Installation	2-58-4
Removal	2-58-3
Testing	2-58-2

Subject

Paragraph,
 Figure, Table,
 Number

R - Continued

Rotating Rectifier	
Description	4-15-4
Installation	4-19-2
Removal	4-19-1
Rotating Rectifier Diodes	
Installation	4-17-3
Removal	4-17-2
Testing	4-17-1

S

Short Circuit/Overload Relay	
Inspection	2-56-1
Installation	2-56-4
Removal	2-56-3
Testing	2-56-2
Shunt	
Inspection	2-54-1
Installation	2-54-4
Removal	2-54-3
Testing	2-54-2
Skid Base	
Description	1-13-13
Location	1-13-13
Removal	4-24-1
Skip Base	
Installation	4-24-3
Repair	4-24-2
Starter	
Description	1-13-9
Location	1-13-9
Storage	2-118
SYNCHRONIZING LIGHTS	
Inspection	2-22-1
Installation	2-22-3
Removal	2-22-2

T

Time Meter (TOTAL HOURS)	
Inspection	2-26-1
Installation	2-26-4
Removal	2-26-3
Testing	2-26-2

Subject	Paragraph, Figure, Table, Number
---------	--

T - Continued

Took and Equipment	
Direct and General Support	3-1
Unit	2-4-1
Top Housing Section	
Inspection	2-16-2
Installation	2-16-4
Removal	2-16-1
Repair	2-16-3
Troubleshooting	
Direct Support	3-1
Unit	2-6
Type of Manual	1-1

U

Upper Coolant Hose	
Cleaning	2-79-2
Inspection	2-79-2
Installation	2-79-3
Removal	2-79-1

V

Varistors	
Inspection	2-105-2
Installation	2-105-2
Removal	2-105-1
Testing	2-105-2
VOLTAGE Adjust Potentiometer, Removal	2-34-2
VOLTAGE Adjust Potentiometer	
Inspection	2-34-1
Installation	2-34-4
Testing	2-34-3
Voltage Reconnection Terminal Board	
Description	1-13-11
Inspection	2-96-1
Installation, Direct Support	4-8-2
Installation, Unit	2-96-3
Location	1-13-11
Removal, Direct Support	4-8-1
Removal, Unit	2-96-2
Voltage Sensing Relay	
Inspection	2-59-1
Installation	2-59-4
Removal	2-59-3
Testing	2-59-2

ARMY TM 9-6115-644-24
AIR FORCE TO 35C2-3-446-12
MARINE CORPS TM 09249A/09246A-24/2

Subject

Paragraph,
Figure, Table,
Number

W

Water Pump

Description

1-13-22

Location

1-13-22

By Order of the Secretaries of the Army, Air Force, and Navy (Including the Marine Corps):

Official:



JOEL B. HUDSON

*Acting Administrative Assistant to the
Secretary of the Army*

00036

GORDON R. SULLIVAN
*General, United States Army
Chief of Staff*

MERRILL A. McPEAK
*General, USAF
Chief of Staff*

RONALD W. YATES
*General, USAF
Commander, Air Force Materiel Command*

DAVID E. BOTTORFF
*Rear Admiral, CEC, US Navy
Commander
Navy Facilities Engineering
Command*

D. R. BLOOMER
*Colonel, USMC
Director, Program Support
Marine Corps Systems Command*

DISTRIBUTION:

To be distributed in accordance with DA Form 12-25-E, block no. 5268, requirements for TM 9-6115-644-24.

These are the instructions for sending an electronic 2028

The following format must be used if submitting an electronic 2028. The subject line must be exactly the same and all fields must be included; however only the following fields are mandatory: 1, 3, 4, 5, 6, 7,8, 9, 10, 13, 15, 16, 17, and 27.

From: "Whomever" <whomever@avma27.army.mil>
To: mpmt%avma28@st-louis-emh7.army.mil

Subject: DA Form 2028

1. **From:** Joe Smith
2. Unit: home
3. **Address:** 4300 Park
4. **City:** Hometown
5. **St:** MO
6. **Zip:** 77777
7. **Date Sent:** 19-OCT-93
8. **Pub no:** 55-2840-229-23
9. **Pub Title:** TM
10. **Publication Date:** 04-JUL-85
11. *Change Number:* 7
12. *Submitter Rank:* MSG
13. **Submitter FName:** Joe
14. *Submitter MName:* T
15. **Submitter LName:** Smith
16. **Submitter Phone:** 123-123-1234
17. **Problem:** 1
18. *Page:* 2
19. *Paragraph:* 3
20. **Line:** 4
21. NSN: 5
22. **Reference:** 6
23. *Figure:* 7
24. *Table:* 8
25. *Item:* 9
26. *Total:* 123
27. **Text:**

This is the text for the problem below line 27.



THEN... JOT DOWN THE DOPE ABOUT IT ON THIS FORM. CAREFULLY TEAR IT OUT. FOLD IT AND DROP IT IN THE MAIL!

SOMETHING WRONG WITH THIS PUBLICATION?

FROM: (PRINT YOUR UNIT'S COMPLETE ADDRESS)

PFC JOHN DOE
COA, 3d ENGINEER BN
FT. LEONARD WOOD, MO 63108

DATE SENT

PUBLICATION NUMBER

TM 9-6115-644-24

PUBLICATION DATE

30 April 1995

PUBLICATION TITLE

GENERATOR SET SKID MOUNTED

BE EXACT. PIN-POINT WHERE IT IS

PAGE NO	PARA-GRAPH	FIGURE NO	TABLE NO
6	2-1 a		
B1		4-3	
125	line 20		

IN THIS SPACE TELL WHAT IS WRONG AND WHAT SHOULD BE DONE ABOUT IT:

In line 6 of paragraph 2-1a the manual states the engine has 6 Cylinders. The engine on my set only has 4 Cylinders. Change the manual to show 4 Cylinders.

Callout 16 on figure 4-3 is pointing at a bolt. In key to figure 4-3, item 16 is called a shim - Please correct one or the other.

I ordered a gasket, item 19 on figure B-16 by NSN 2 910-00-762-3001. I got a gasket but it doesn't fit. Supply says I got what I ordered, so the NSN is wrong. Please give me a good NSN

PRINTED NAME, GRADE OR TITLE, AND TELEPHONE NUMBER

JOHN DOE, PFC (268) 317-7111

SIGN HERE

JOHN DOE

TEAR ALONG PERFORATED LINE

FILL IN YOUR
UNITS ADDRESS



FOLD BACK

DEPARTMENT OF THE ARMY

OFFICIAL BUSINESS

COMMANDER
U.S. ARMY AVIATION AND TROOP COMMAND
ATTN: AMSAT-I-MP
4300 GOODFELLOW BOULEVARD
ST. LOUIS, MO 63120-1798

TEAR ALONG PERFORATED LINE

RECOMMENDED CHANGES TO EQUIPMENT TECHNICAL PUBLICATIONS



SOMETHING WRONG WITH THIS PUBLICATION?

THEN, JOT DOWN THE DOPE ABOUT IT ON THIS FORM. CAREFULLY TEAR IT OUT, FOLD IT AND DROP IT IN THE MAIL.

FROM: (PRINT YOUR UNIT'S COMPLETE ADDRESS)

DATE SENT

PUBLICATION NUMBER
TM 9-6115-644-24

PUBLICATION DATE
30 April 1995

PUBLICATION TITLE
GENERATOR SET, SKID MOUNTED

BE EXACT PIN-POINT WHERE IT IS				IN THIS SPACE TELL WHAT IS WRONG AND WHAT SHOULD BE DONE ABOUT IT:
PAGE NO	PARA-GRAPH	FIGURE NO	TABLE NO	

PRINTED NAME GRADE OR TITLE AND TELEPHONE NUMBER

SIGN HERE

FILL IN YOUR
UNITS ADDRESS



FOLD BACK

DEPARTMENT OF THE ARMY

OFFICIAL BUSINESS

COMMANDER
U.S. ARMY AVIATION AND TROOP COMMAND
ATTN: AMSAT-I-MP
4300 GOODFELLOW BOULEVARD
ST. LOUIS, MO 63120-1798

TEAR ALONG PERFORATED LINE

RECOMMENDED CHANGES TO EQUIPMENT TECHNICAL PUBLICATIONS



THEN JOT DOWN THE DOPE ABOUT IT ON THIS FORM. CAREFULLY TEAR IT OUT. FOLD IT AND DROP IT IN THE MAIL.

SOMETHING WRONG WITH THIS PUBLICATION?

FROM (PRINT YOUR UNIT'S COMPLETE ADDRESS)

DATE SENT

PUBLICATION NUMBER
TM 9-6115-644-24

PUBLICATION DATE
30 April 1995

PUBLICATION TITLE
GENERATOR SET, SKID MOUNTED

BE EXACT PIN-POINT WHERE IT IS

PAGE NO	PARA-GRAPH	FIGURE NO	TABLE NO

IN THIS SPACE TELL WHAT IS WRONG AND WHAT SHOULD BE DONE ABOUT IT:

PRINTED NAME GRADE OR TITLE AND TELEPHONE NUMBER

SIGN HERE

FILL IN YOUR
UNITS ADDRESS



FOLD BACK

DEPARTMENT OF THE ARMY

OFFICIAL BUSINESS

COMMANDER
U.S. ARMY AVIATION AND TROOP COMMAND
ATTN: AMSAT-I-MP
4300 GOODFELLOW BOULEVARD
ST. LOUIS, MO 63120-1798

TEAR ALONG PERFORATED LINE

The Metric System and Equivalents

Linear Measure

1 centimeter = 10 millimeters = .39 inch
 1 decimeter = 10 centimeters = 3.94 inches
 1 meter = 10 decimeters = 39.37 inches
 1 dekameter = 10 meters = 32.8 feet
 1 hectometer = 10 dekameters = 328.08 feet
 1 kilometer = 10 hectometers = 3,280.8 feet

Weights

1 centigram = 10 milligrams = .15 grain
 1 decigram = 10 centigrams = 1.54 grains
 1 gram = 10 decigram = .035 ounce
 1 dekagram = 10 grams = .35 ounce
 1 hectogram = 10 dekagrams = 3.52 ounces
 1 kilogram = 10 hectograms = 2.2 pounds
 1 quintal = 100 kilograms = 220.46 pounds
 1 metric ton = 10 quintals = 1.1 short tons

Liquid Measure

1 centiliter = 10 milliliters = .34 fl. ounce
 1 deciliter = 10 centiliters = 3.38 fl. ounces
 1 liter = 10 deciliters = 33.81 fl. ounces
 1 dekaliter = 10 liters = 2.64 gallons
 1 hectoliter = 10 dekaliters = 26.42 gallons
 1 kiloliter = 10 hectoliters = 264.18 gallons

Square Measure

1 sq. centimeter = 100 sq. millimeters = .155 sq. inch
 1 sq. decimeter = 100 sq. centimeters = 15.5 sq. inches
 1 sq. meter (centare) = 100 sq. decimeters = 10.76 sq. feet
 1 sq. dekameter (are) = 100 sq. meters = 1,076.4 sq. feet
 1 sq. hectometer (hectare) = 100 sq. dekameters = 2.47 acres
 1 sq. kilometer = 100 sq. hectometers = .386 sq. mile

Cubic Measure

1 cu. centimeter = 1000 cu. millimeters = .06 cu. inch
 1 cu. decimeter = 1000 cu. centimeters = 61.02 cu. inches
 1 cu. meter = 1000 cu. decimeters = 35.31 cu. feet

Approximate Conversion Factors

To change	To	Multiply by	To change	To	Multiply by
inches	centimeters	2.540	ounce-inches	newton-meters	.007062
feet	meters	.305	centimeters	inches	.394
yards	meters	.914	meters	feet	3.280
miles	kilometers	1.609	meters	yards	1.094
square inches	square centimeters	6.451	kilometers	miles	.621
square feet	square meters	.093	square centimeters	square inches	.155
square yards	square meters	.836	square meters	square feet	10.764
square miles	square kilometers	2.590	square meters	square yards	1.196
acres	square hectometers	.405	square kilometers	square miles	.386
cubic feet	cubic meters	.028	square hectometers	acres	2.471
cubic yards	cubic meters	.765	cubic meters	cubic feet	35.315
fluid ounces	milliliters	29.573	cubic meters	cubic yards	1.308
pints	liters	.473	milliliters	fluid ounces	.034
quarts	liters	.946	liters	pints	2.113
gallons	liters	3.785	liters	quarts	1.057
ounces	grams	28.349	liters	gallons	.264
pounds	kilograms	.454	grams	ounces	.035
short tons	metric tons	.907	kilograms	pounds	2.205
pound-foot	newton-meters	1.356	metric tons	short tons	1.102
pound-inches	newton-meters	.11296			

Temperature (Exact)

°F	Fahrenheit temperature	5/9 (after subtracting 32)	Celsius temperature	°C
----	------------------------	----------------------------	---------------------	----

